



---

**1986**

---

**BMW 735i**

---

**Electrical**

---

**Troubleshooting**

---

**Manual**

---

BMW of North America, Inc.  
Montvale, New Jersey

## FOREWORD

In the interests of continuing technical development work we reserve the right to modify designs and equipment.

Printed in USA

© Copyright BMW of North America, Inc.

Not to be reproduced wholly or in part  
without written permission of  
BMW of North America, Inc.  
PN 01 00 1 467 814

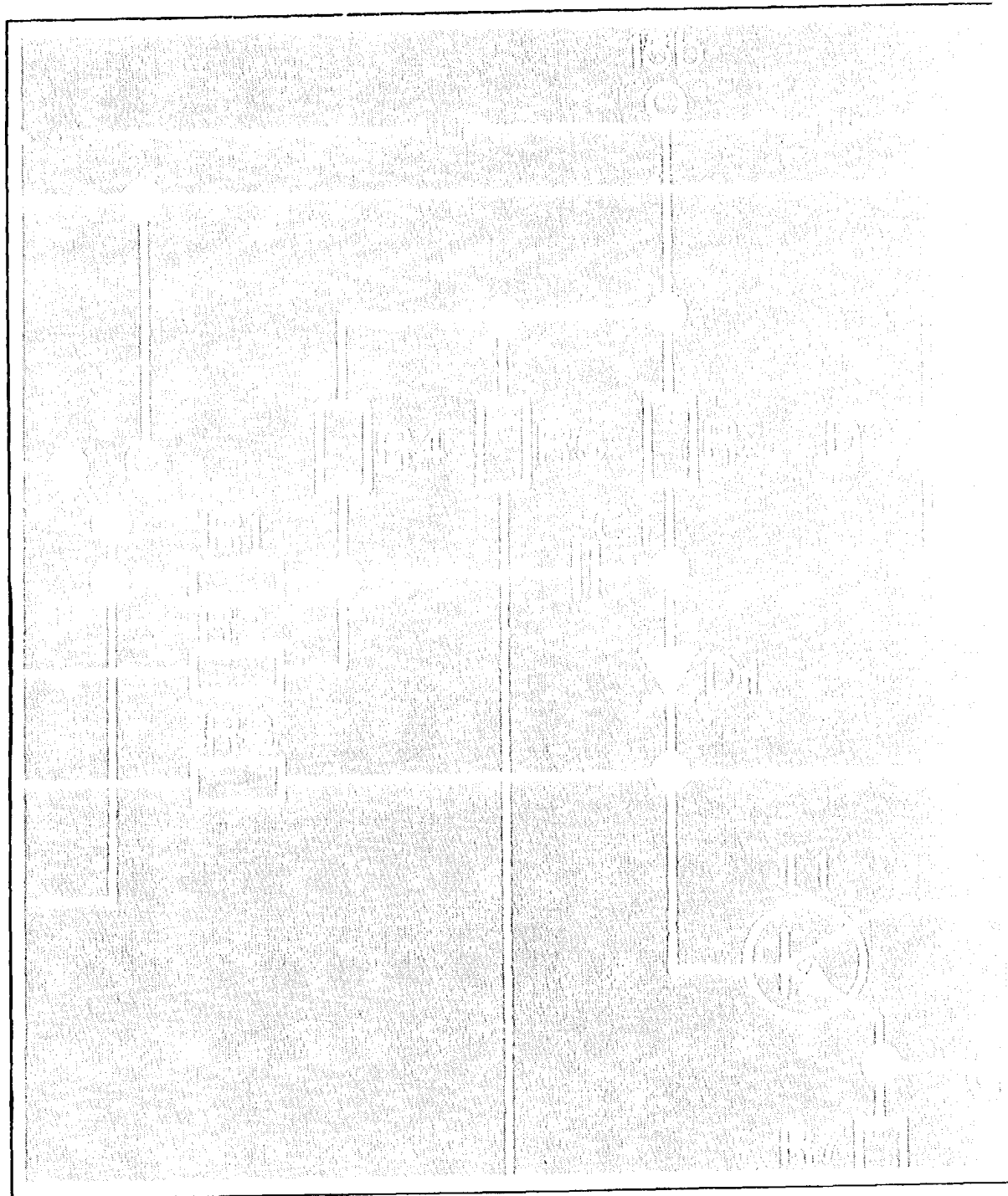

**1986/1987  
BMW 735i, L7  
Electrical  
Troubleshooting  
Manual**

**CONTENTS**

---

Index .....	2
How To Use This Manual .....	3
Symbols .....	4
Wire Size Conversion Chart ...	5
Systematic Troubleshooting ..	6
Connector Views .....	8500-0
Power Distribution Box .....	0670-0
Fuse Data .....	0670-1
Component Location Chart ...	9000-0
Component Location Views ..	7000-0
Splice Location Views .....	8000-0

---

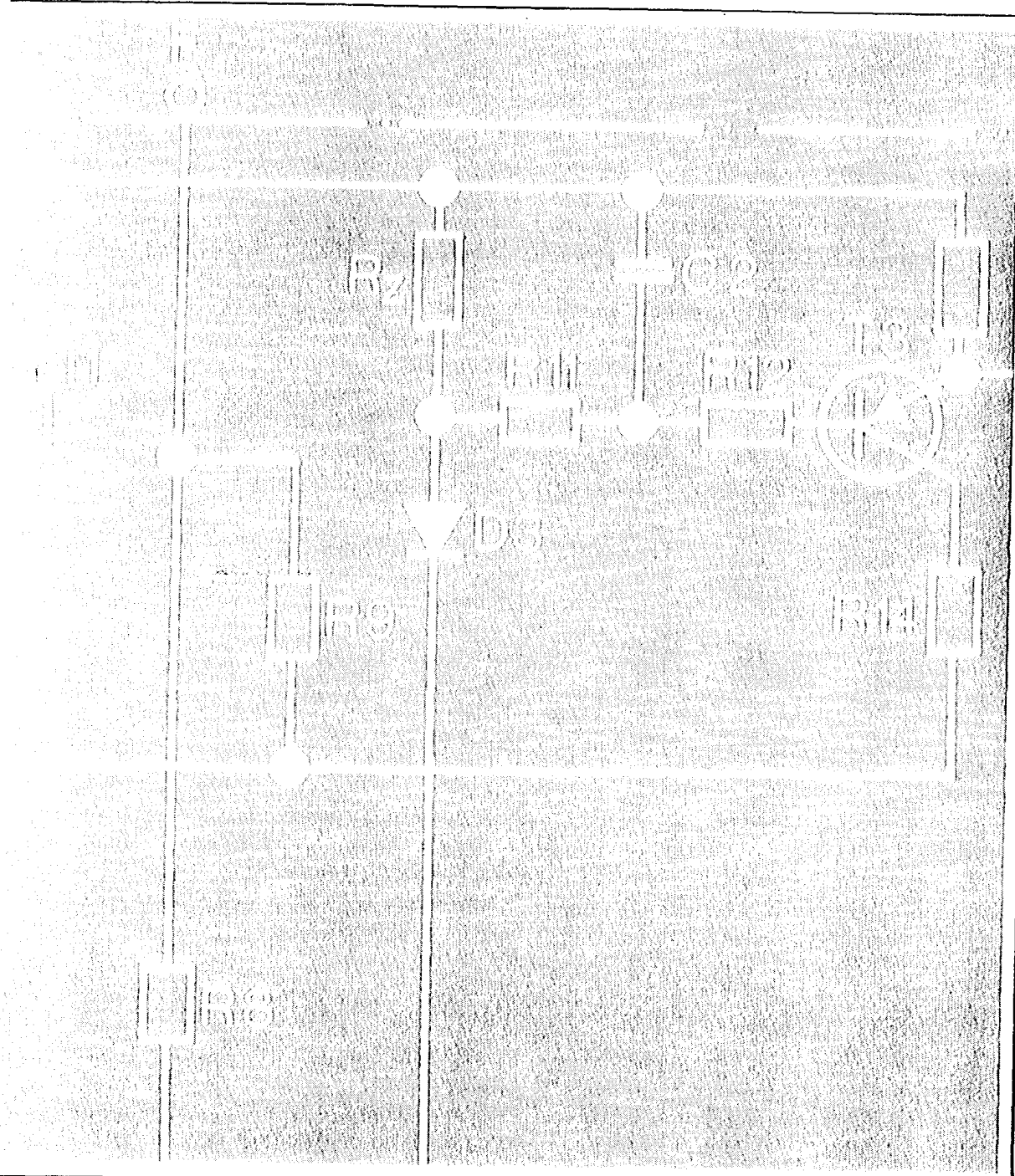

### Index — Alphabetical Listing of Electrical Circuits

	PAGE		PAGE		PAGE
Accessory Fuse Box . . . . .	0670- 2	— G302. . . . .	0670-17	— Hazard Warning. . . . .	6313- 0
Active Check Control . . . . .	6216- 0	Heated Door Locks. . . . .	6100- 0	— Headlights . . . . .	6312- 0
Anti Lock Braking System (ABS) . . . . .	3450- 0	Heated Seats . . . . .	5200- 6	— Interior. . . . .	6330- 0
A/C Air Delivery Control . . . . .	6421- 0	Horn . . . . .	6100- 0	— License . . . . .	6320- 0
A/C Blower Control . . . . .	6413- 0	Idle Speed Control . . . . .	1360- 0	— Map Reading. . . . .	6100- 1
A/C Compressor Control . . . . .	6452- 0	Ignition . . . . .	1360- 2	— Park. . . . .	6314- 0
A/C Temperature Control . . . . .	6411- 0	Ignition Key Warning . . . . .	6131- 0	— Reading . . . . .	6320- 0
Auto-Charging Flashlight . . . . .	6100- 1	Indicators		— Rear Marker . . . . .	6320- 0
Auxiliary Fan. . . . .	6454- 0	— Active Check Control Alarm. . . . .	6210- 1	— Stop Lights . . . . .	6325- 0
Body Electrical . . . . .	6100- 0	— “Brake Lights” Fault . . . . .	6216- 2	— Tail . . . . .	6314- 0
Brake Lining Warning . . . . .	3435- 0	— “Brake Lining” Wear . . . . .	3435- 0	— Transmission Range. . . . .	6300- 0
Central Locking . . . . .	5126- 0	— “Brake” Warning. . . . .	6210- 2	— Turn . . . . .	6313- 1
Charging System . . . . .	1230- 0	— Charge Indicator . . . . .	6210- 0	— Trunk. . . . .	6320- 0
Cigar Lighter . . . . .	6100- 0	— “Coolant” Level Fault. . . . .	6216- 3	— Underhood . . . . .	6314- 0
Component Location Views. . . . .	7000- 0	— “Engine Oil” Fault . . . . .	6216- 3	— Visor . . . . .	6300- 0
Connector Views. . . . .	8500- 0	— Fasten Seatbelts . . . . .	6216- 3	Light Switch Details. . . . .	6300- 0
Cruise Control. . . . .	6571- 0	— Fog Lights . . . . .	6210- 2	Memory Seats. . . . .	5200- 2
Electronic Transmission Control . . . . .	2460- 0	— High Beam . . . . .	6210- 2	On-Board Computer . . . . .	6581- 0
Engine Control Block Diagrams. . . . .	1250- 0	— Inspection . . . . .	6210- 3	Power Antenna . . . . .	6500- 0
Fuel Control . . . . .	1360- 0	— LH Turn . . . . .	6210- 2	Power Distribution . . . . .	0670- 2
Fuel Delivery. . . . .	1360- 1	— “License Plate” Fault . . . . .	6216- 1	Power Distribution Box . . . . .	0670- 0
Fuel Gauge . . . . .	6210- 1	— “Low Beam” Fault. . . . .	6216- 0	Power Mirrors . . . . .	5116- 0
Fuse Data Chart. . . . .	0670- 1	— Low Fuel Warning . . . . .	6210- 1	Power Seats . . . . .	5200- 0
Fuse Details		— Oil Pressure Warning . . . . .	6210- 1	Power Windows . . . . .	5133- 0
— Fuse 6 . . . . .	0670- 9	— Oil Service . . . . .	6210- 3	Radio. . . . .	6500- 0
— Fuse 9 . . . . .	0670- 8	— “Park Brake” . . . . .	6210- 1	Rear Window Defogger. . . . .	6100- 2
— Fuse 12 . . . . .	0670- 9	— “Rear Lights” Fault . . . . .	6216- 1	Seatbelt Warning Indicator . . . . .	6131- 0
— Fuse 16 . . . . .	0670- 8	— RH Turn . . . . .	6210- 2	Service Interval Display. . . . .	6210- 3
— Fuse 17 . . . . .	0670- 7	— SRS. . . . .	6216- 2	Speedometer . . . . .	6210- 0
— Fuse 21 . . . . .	0670-11	— Temperature Warning. . . . .	6210- 1	Splice Location Index . . . . .	8000- 0
— Fuse 26 . . . . .	0670-10	— “Washer Fluid” Fault . . . . .	6216- 3	Start . . . . .	1240- 0
— Fuse 27 . . . . .	0670-10	Injection Electronics. . . . .	1360- 0	Sunroof . . . . .	5413- 0
— Fuse 28 . . . . .	0670-10	Instrument Cluster . . . . .	6210- 0	Supplemental Restraint System (SRS)	
Gauges . . . . .	6210- 0	Lights		. . . . .	3234- 0
Ground Distribution		— Backup . . . . .	6322- 0	Temperature Gauge . . . . .	6210- 1
— G103. . . . .	0670-12	— Center Console . . . . .	6330- 1	Vacuum Pump. . . . .	6454- 0
— G104. . . . .	0670-12	— Dash . . . . .	6300- 0	Warning Indicators. . . . .	6210- 0
— G200. . . . .	0670-14	— Fog . . . . .	6312- 0	Windshield Washer Jet Heaters . . . . .	6160- 1
— G203. . . . .	0670-16	— Front Park. . . . .	6314- 0	Wiper/Washer . . . . .	6160- 0
— G301. . . . .	0670-17	— Glove Box. . . . .	6100- 1		

The purpose of this manual is to show electrical schematics in a manner that makes electrical troubleshooting easier. Electrical components which work together are shown together on one schematic. The Wiper-Washer schematic, for example, shows all of the electrical components in one diagram. At the top of the page is the fuse (positive) that powers the circuit. The flow of current is shown through all wires, connectors, switches, and motors to ground (negative) at the bottom of the page.

Within the schematic, all switches and sensors are shown "at rest," as though the Ignition Switch were off. For identification, component names are underlined and placed next to or above each component. Notes are included, describing how switches and other components work.

The power distribution schematic shows the current feed through all the connections from the Battery and Alternator to each fuse and the Ignition and Light Switches. If the Power Distribution schematic is combined with any other circuit schematic, a complete picture is made of how that circuit works. The Ground Distribution schematics show how several circuits are connected to common grounds.

All wiring between components is shown exactly as it exists in the vehicle; however, the wiring is not drawn to scale. To aid in understanding electrical operation, wiring inside complicated components has been simplified. The "Solid State" label designates electronic components.

WIRE SIZE CONVERSION CHART	
METRIC (CROSSSECTIONAL AREA IN MM <sup>2</sup> )	AWG (AMERICAN WIRE GAUGE)
.5	20
.75	18
1	16
1.5	14
2	14
2.5	12
4	10
6	8
8	8
16	4
20	4
25	2
32	2

WIRE INSULATION	
ABBREVIATIONS	COLOR
BK	BLACK
BR	BROWN
RD	RED
YL	YELLOW
GN	GREEN
BU	BLUE
VI	VIOLET
GY	GRAY
WT	WHITE
PK	PINK



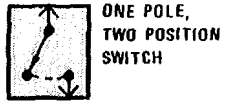

ONE POLE,  
TWO POSITION  
SWITCH

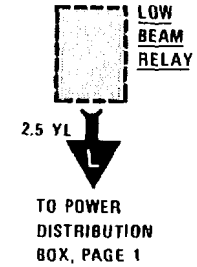
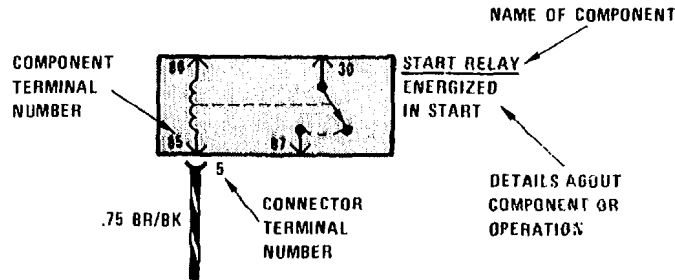

CURRENT PATH  
IS CONTINUED  
AS LABELED.  
THE ARROW SHOWS  
DIRECTION OF CURRENT  
FLOW AND IS REPEATED  
WHERE CURRENT  
PATH CONTINUES.

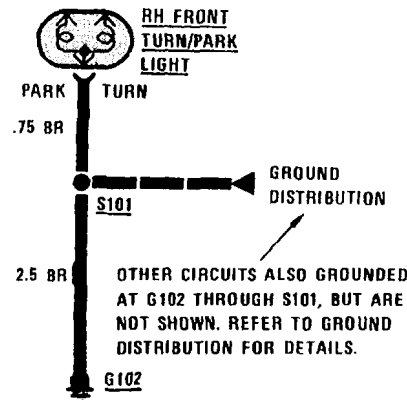
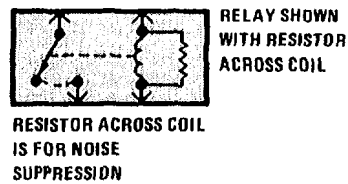
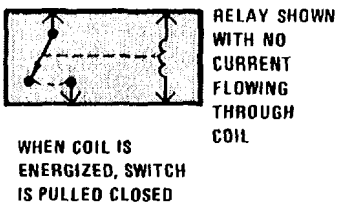
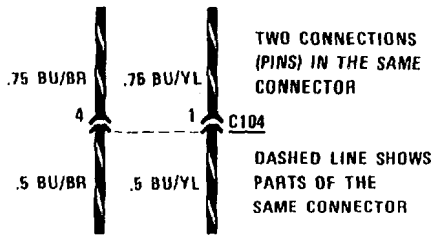
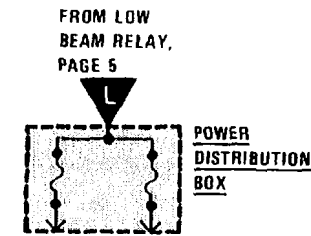
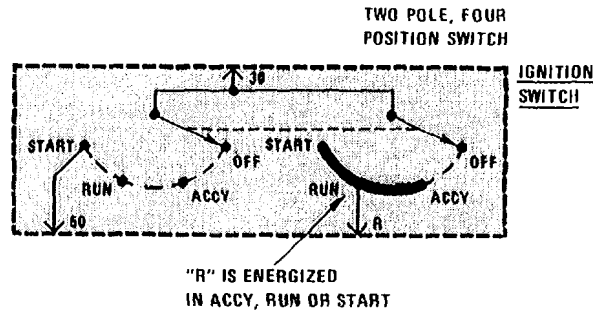
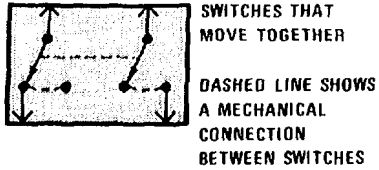

LIGHT  
EMITTING  
DIODE

## 6 SYSTEMATIC TROUBLESHOOTING

### TROUBLESHOOTING PROCEDURE

#### 1. Verify the Problem

Operate the problem circuit to check the accuracy of the complaint. Note the symptoms of the inoperative circuit.

#### 2. Analyze the Problem

Refer to the schematic of the problem circuit in the ETM. Determine how the circuit is supposed to work by tracing the current path(s) from the power feed through the circuit components to ground. Then based on the symptoms you noted in step 1 and your understanding of circuit operation, identify one or more possible causes of the problem.

#### 3. Isolate the Problem

Make circuit tests to prove or disprove the preliminary diagnosis made in step 2. Keep in mind that a logical simple procedure is the key to efficient troubleshooting. Test for the most likely cause of failure first. Try to make tests at points which are easily accessible.

#### 4. Repair the Problem

Once the specific problem is identified, make the repair using the proper tools and safe procedures.

#### 5. Check the Problem

Operate the circuit to check for satisfactory circuit operation. Good repair practice calls for rechecking all circuits you have worked on.

### TROUBLESHOOTING TOOLS

Isolating the problem (Step 3 of TROUBLESHOOTING PROCEDURES) requires the use of a **voltmeter** and/or **ohmmeter**. A voltmeter measures voltage at selected points in a circuit. An ohmmeter measures a circuit's resistance to current flow. It has an internal battery that provides current to the circuit under test. Disconnect the car battery when using an ohmmeter because the battery voltage will cause the ohmmeter to give false readings. Also, do not use an ohmmeter on solid-state components. The voltage that the ohmmeter applies to the circuit could damage these components.

### TROUBLESHOOTING TESTS

#### Voltage Test

This test measures voltage in a circuit. By taking measurements at several points (terminals or connectors) along the circuit, you can isolate the problem.

To take a voltage measurement, connect the negative lead of the voltmeter to the battery's negative terminal or other known good ground. Then connect the positive lead of the voltmeter to the point you want to test. The voltmeter will measure the voltage present at that point in the circuit.

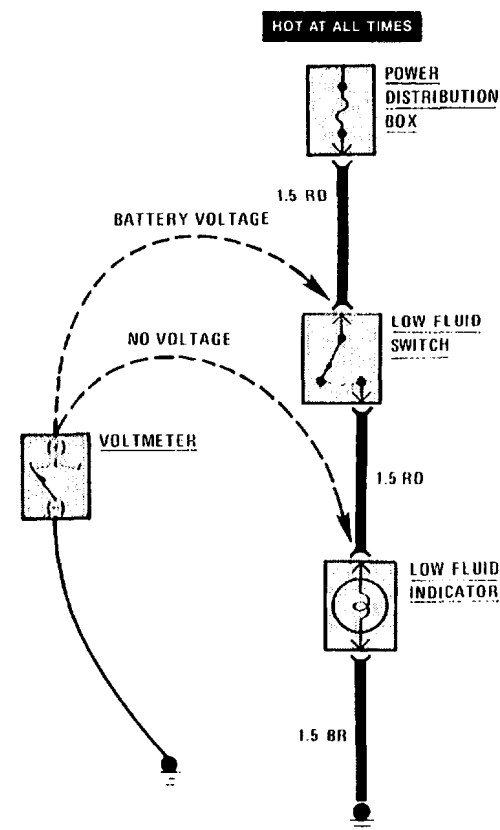

Voltage Test



Voltage Drop Test

Wires, connectors, and switches are designed to conduct current with a minimum loss of voltage. A voltage drop of more than one volt indicates a problem.

To test for voltage drop, connect the voltmeter leads to connectors at either end of the circuit's suspected problem area. The positive lead should be connected to the connector closest to the power source. The voltmeter will show the voltage drop between these two points.

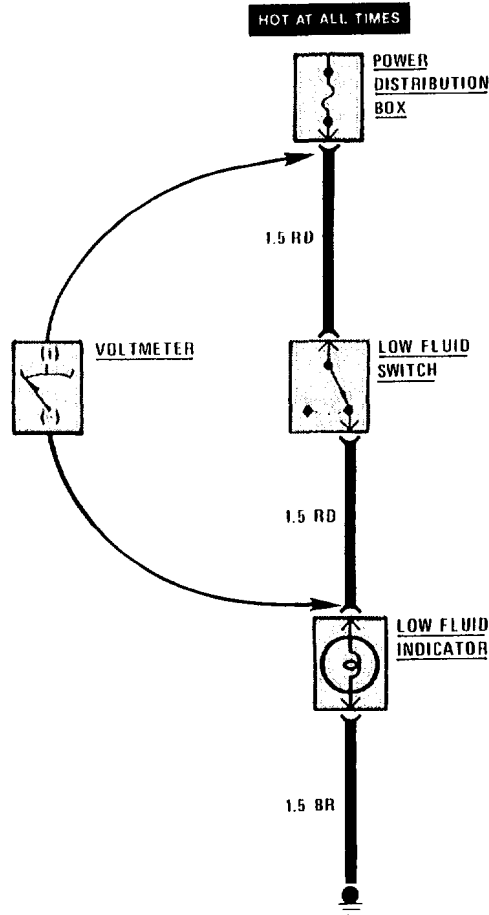

Voltage Drop Test

Continuity Test

To perform a continuity test, first disconnect the car battery. Then adjust the ohmmeter to read zero while holding the leads together. Connect the ohmmeter leads to connector or terminals at either end of the circuit's suspected problem area. The ohmmeter will show the resistance across that part of the circuit.

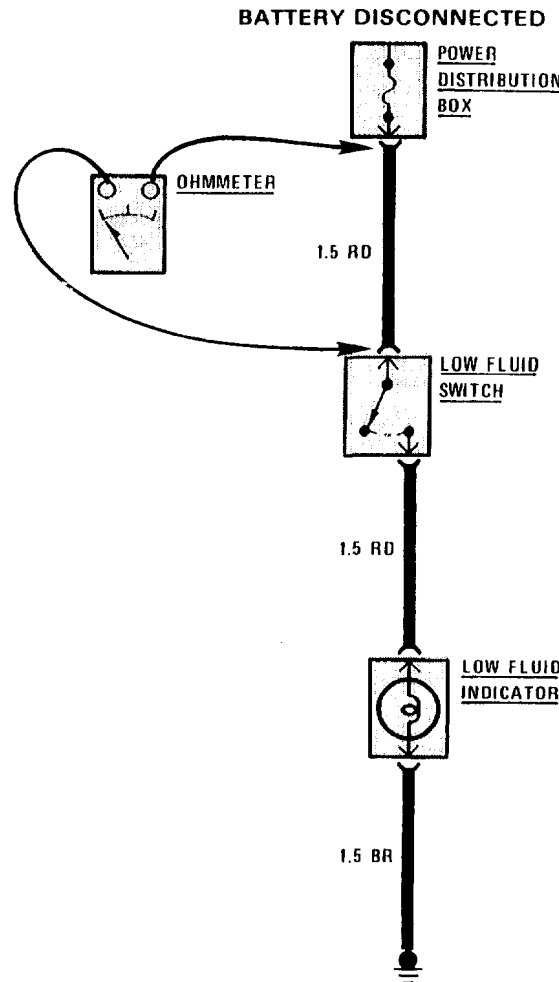

Continuity Test

Short Test Using Voltmeter

Remove the blown fuse and disconnect the load. Connect the voltmeter leads to the fuse terminals. The positive lead should be connected to the terminal closest to the power source.

Starting near the POWER DISTRIBUTION BOX, move the wire harness back and forth and watch the voltmeter reading. If the voltmeter registers a reading, there is a short to ground in the wiring. Somewhere in the area of the harness being moved, the wire insulation is worn away and the circuit is grounding.

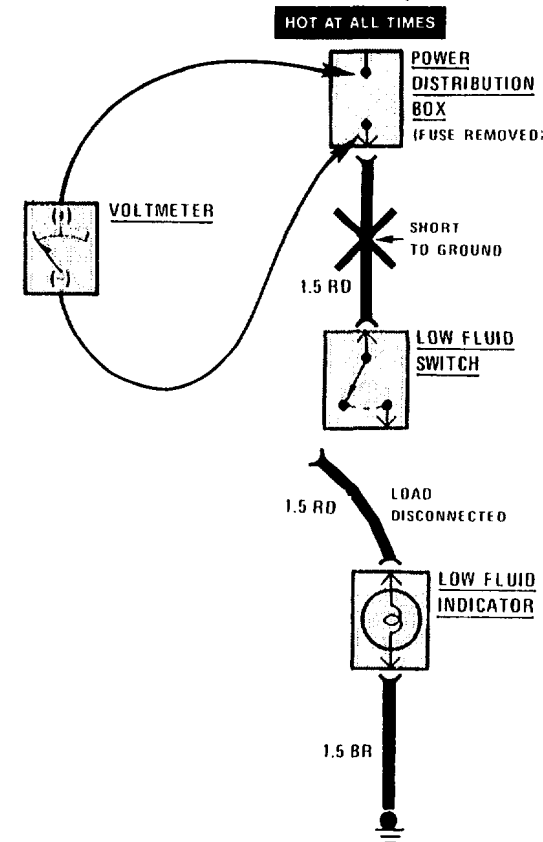

Short Test Using Voltmeter

## 8 SYSTEMATIC TROUBLESHOOTING

### Short Test Using Ohmmeter

Disconnect the battery. Adjust the ohmmeter to read zero while holding the leads together. Remove the blown fuse and disconnect the load. Connect one lead of the ohmmeter to the fuse terminal that is closest to the load. Connect the other lead to a known good ground.

Starting near the POWER DISTRIBUTION BOX, move the wire harness back and forth and watch the ohmmeter reading. Low or no resistance indicates a short to ground in the wiring. Infinitely high resistance indicates no short.

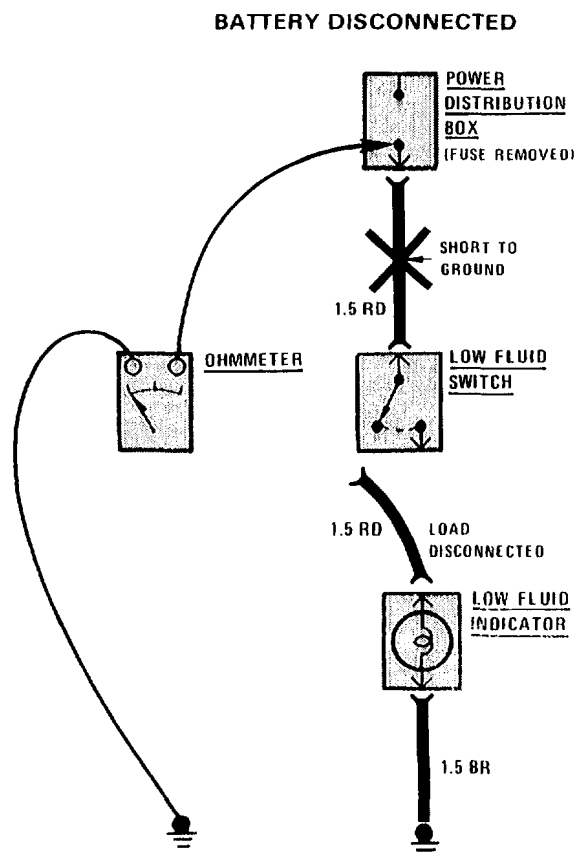

Short Test Using Ohmmeter

# 0670-0 POWER DISTRIBUTION

## POWER DISTRIBUTION BOX

**NOTE**  
 On some cars, the position of the Fuel Pump and Oxygen Sensor Heater may be the opposite of what is shown. Check relay wire colors for positive identification.

FUEL PUMP RELAY

OXYGEN SENSOR HEATER RELAY

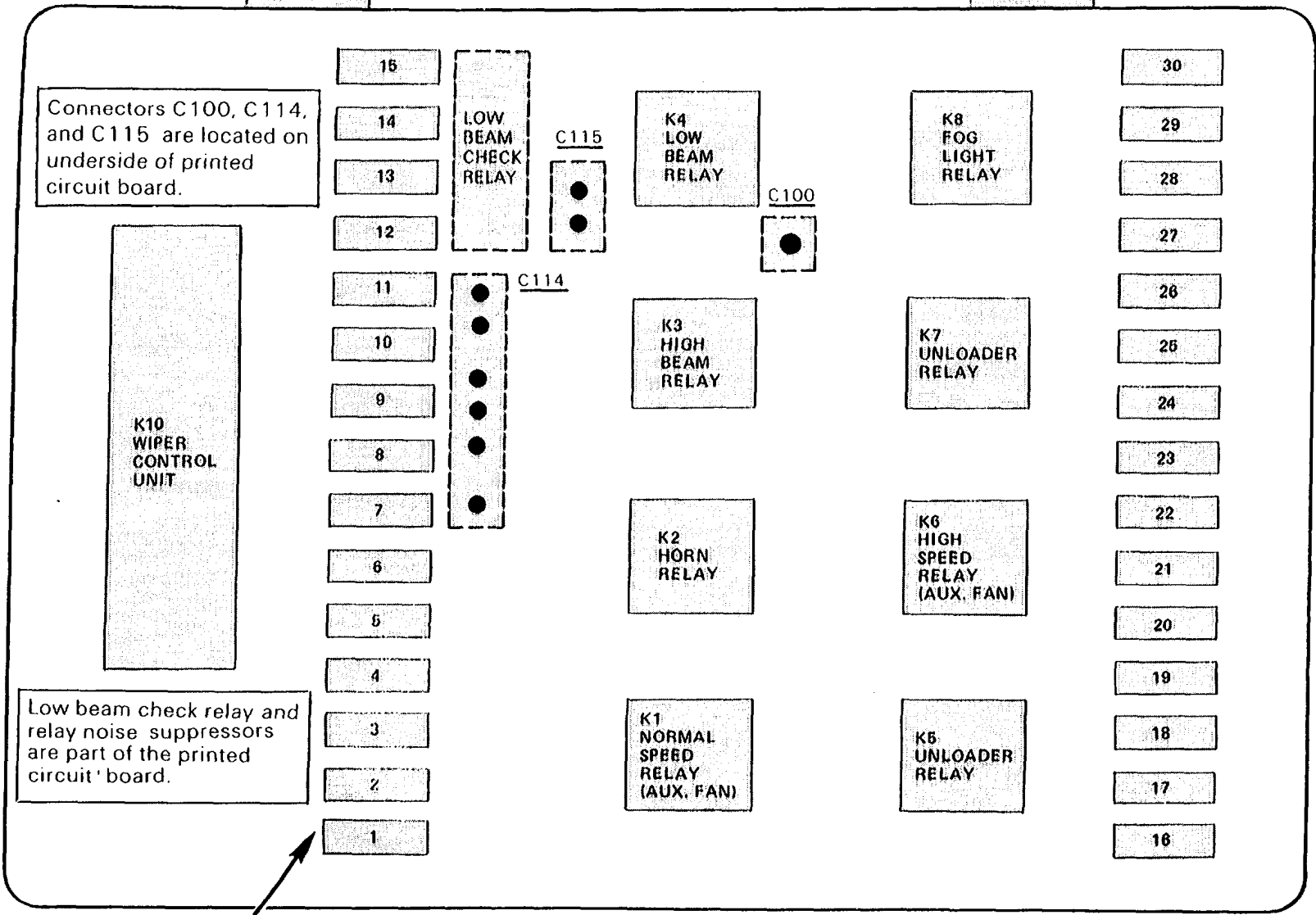

Connectors C100, C114, and C115 are located on underside of printed circuit board.

Low beam check relay and relay noise suppressors are part of the printed circuit board.

FRONT OF CAR

FUSES

Figure 1 - Top Front Of Left Front Wheel Well

## FUSE DATA CHART

Fuse No.	Size Color	Circuit Protected
1	15A (LT BU)	Headlights (also fuses 2, 13 & 14).
2	15A (LT BLU)	Headlights (also fuses 1, 13 & 14).
3	15A (LT BLU)	Auxiliary Fan (also fuses 16 & 18).
4	15A (LT BU)	Lights: Turn/Hazard Warning (also fuse 24).
5	30A (WT)	Wiper/Washer, Windshield Washer Jet Heaters.
6	7.5A (BR)	Active Check Control (also fuses 10, 12, 21, 22 & 23); Stop Lights/Cruise Control/Map Light (also fuse 17).
7	15A (LT BU)	Horn.
8	—	Not Used.
9	15A (BR)	Back Up Lights; Fuel Control
10	7.5A (BR)	Active Check Control (also fuses 6, 12, 21, 22 & 23); Brake Lining Warning; On-Board Computer (also fuses 12, 21 & 27); Seatbelt Warning; Service Interval Indicator (also fuse 21); Speedometer/Gauges/Warning Indicators.
11	15A (LT BU)	Fuel Delivery.
12	7.5A (BR)	Active Check Control (also fuses 6, 10, 21, 22 & 23); On-Board Computer (also fuses 10, 21 & 27); Radio (also fuse 21, Radio In-Line Fuse); Warning Indicators.
13	7.5A (BR)	Headlights (also fuses 1, 2 & 14).
14	7.5A (BR)	Headlights (also fuses 1, 2 & 13).
15	—	Not Used.
16	30A (LT GN)	Auxiliary Fan/Vacuum Pump (also fuses 3 & 18); Heater/Air Conditioning (also fuse 17).
17	15A (LT BU)	Heater/Air Conditioning (also fuse 16); Interior Lights (also fuse 21); Power Mirrors; Power Windows (also fuse 26); Seatbelt Warning (also fuses 10 & 21); Stop Lights/Cruise Control (also fuse 6); Windshield Washer Jet Heaters.

Fuse No.	Size Color	Circuit Protected
18	30A (LT GN)	Auxiliary fan.
19	30A (LT GN)	Sunroof, Heated Seats.
20	30A (LT GN)	Rear Defogger (also fuse 23).
21	7.5A (BR)	Active Check Control (also fuses 6, 10, 12, 22 & 23); Auto-Charging Flashlight; Gauges; Glove Box Light; Interior Lights (also fuse 17); On-Board Computer (also fuses 10, 12 & 27); Radio (also fuse 12); Service Interval Indicator (also fuse 10); Trunk Lights.
22	7.5A (BR)	Active Check Control (also fuses 6, 10, 12, 21 & 23); Lights: Front Park/Tail.
23	7.5A (BR)	Active Check Control (also fuses 6, 10, 12, 21 & 22); Rear Defogger (also 20); Lights: Front Park/Tail Underhood (also fuse 22); Lights: Visor/Dash; Lights: Rear Marker/Lights: Turn/Hazard Warning (also fuse 4).
24	15A (LT BU)	Lights: Turn/Hazard Warning (also fuse 4).
25	—	Not Used.
26	30A (LT GN)	Power Seats; Power Windows (also fuse 17).
27	30A (LT GN)	Central Locking; Heated Door Lock On-Board Computer (also fuses 10, 12 & 21).
28	30A (LT GN)	Cigar Lighter; Power Antenna (Radio In-Line Fuse)
29	7.5A (BR)	Fog Lights (also fuse 30).
30	7.5A (BR)	Fog Lights (also fuse 29).
32	30A	Accessory Fuse (Not Used)
33	30A	Accessory Fuse (Not Used)
Power Window Circuit Breaker	25A	Power Windows

# 0670-2 POWER DISTRIBUTION

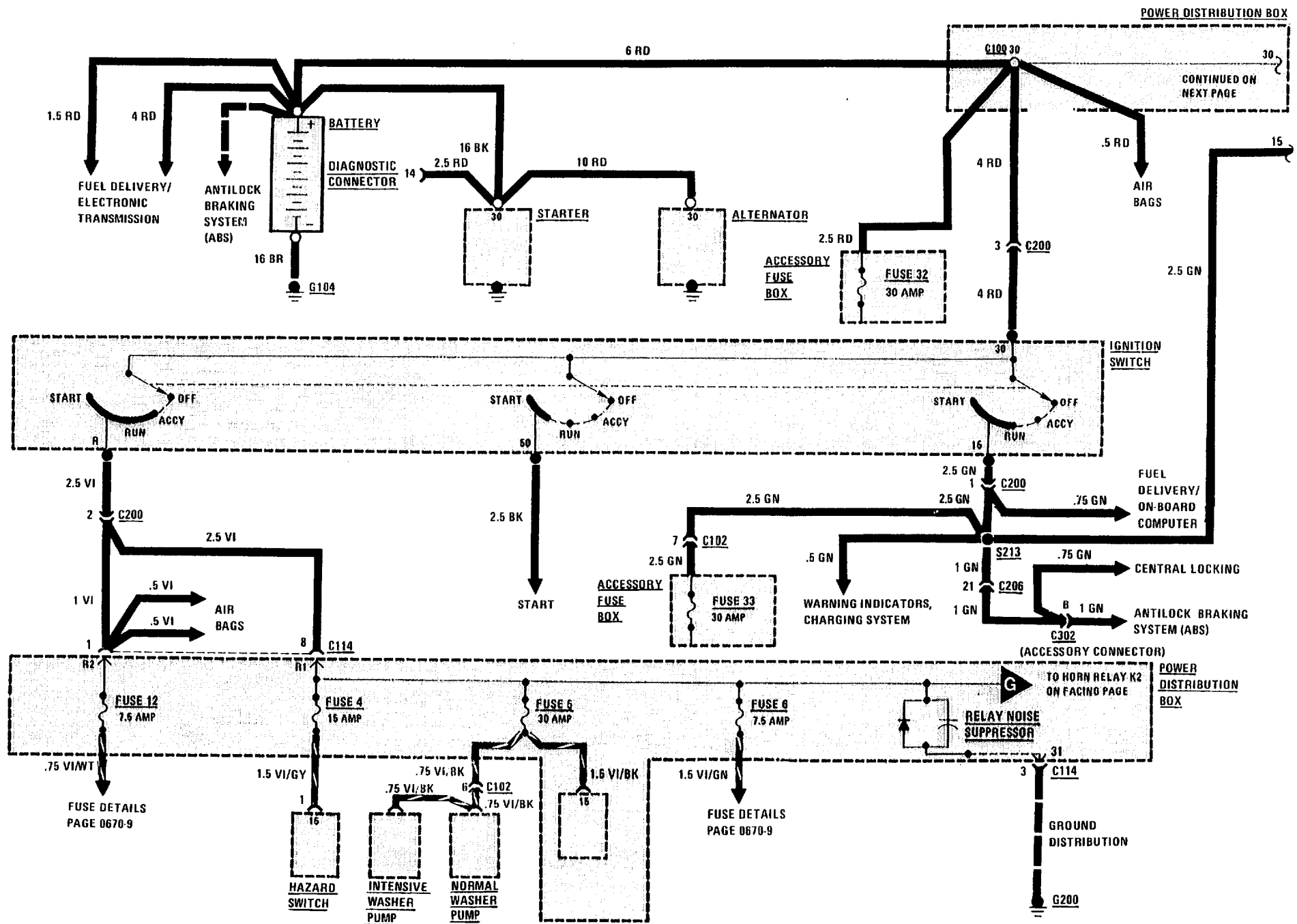

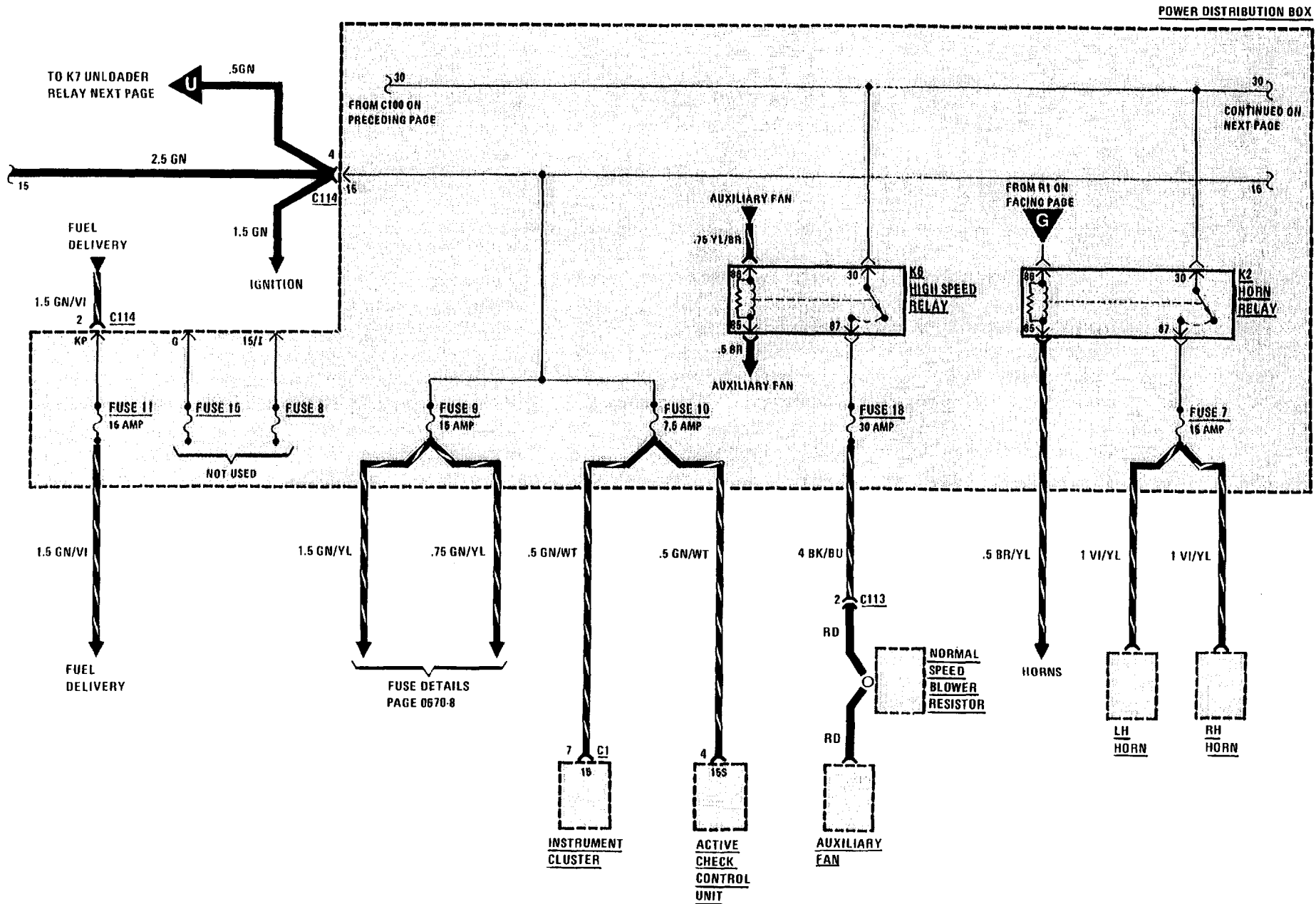

# 0670-4 POWER DISTRIBUTION

POWER DISTRIBUTION BOX

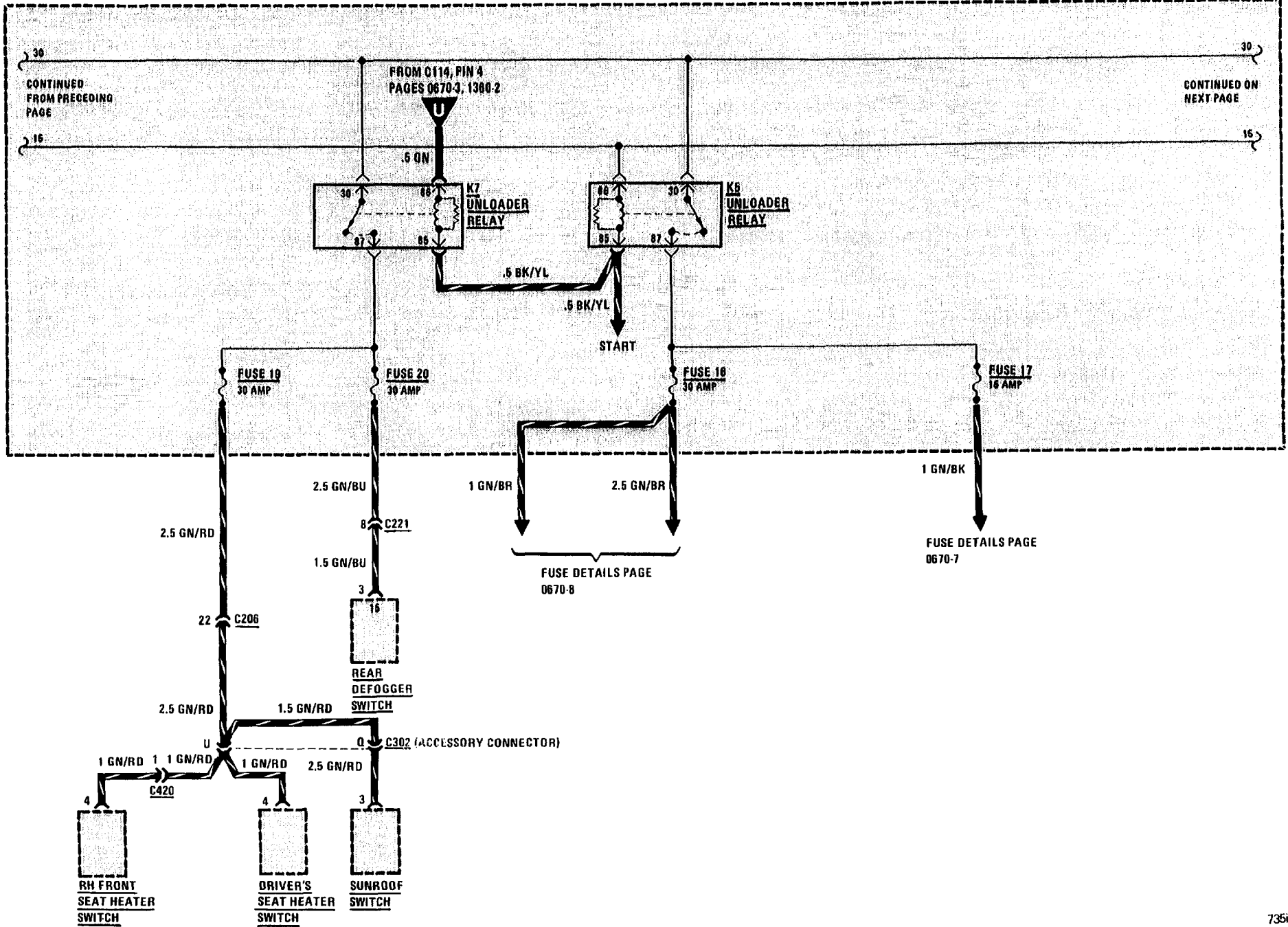

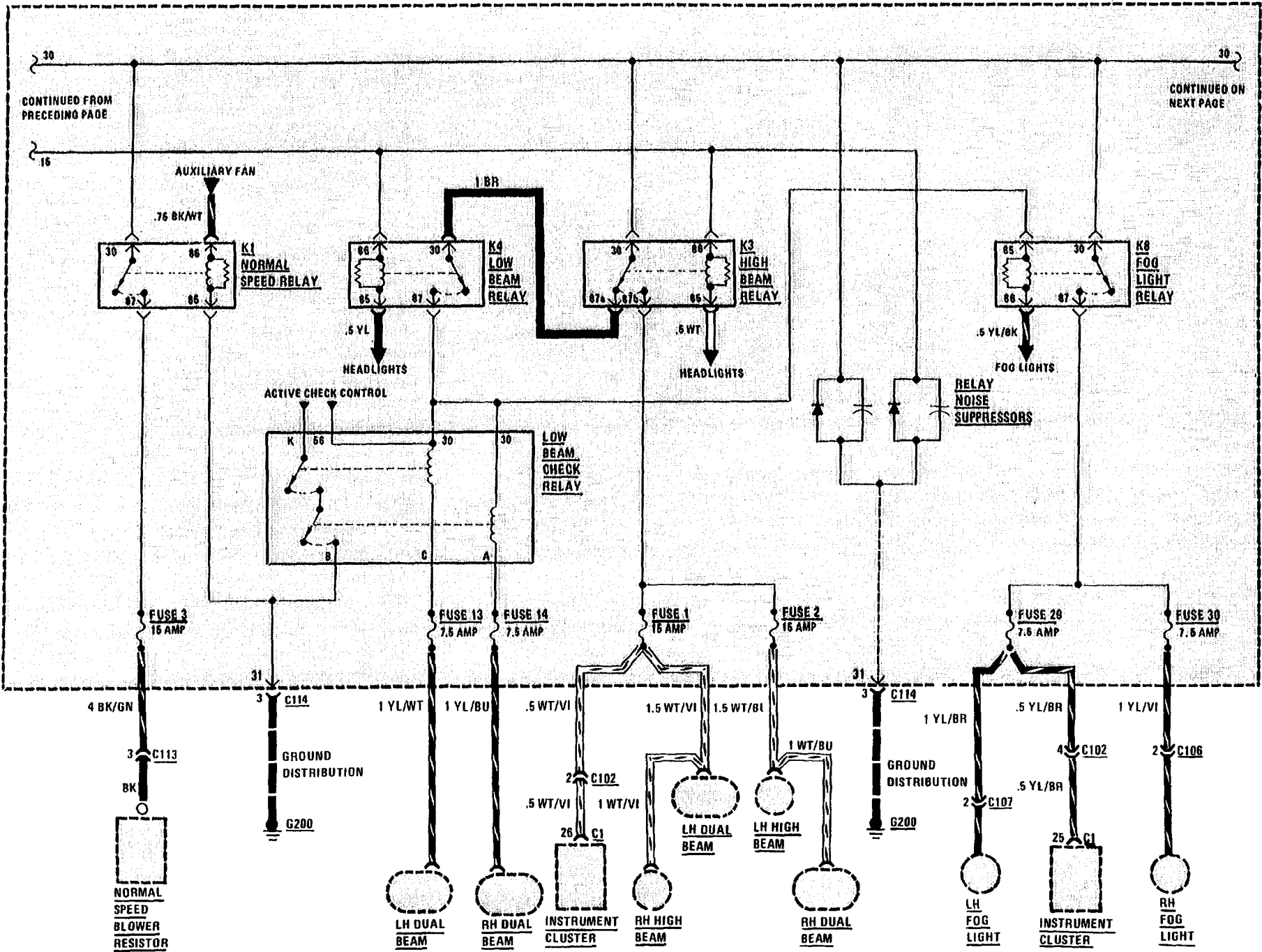



# 0670-6 POWER DISTRIBUTION

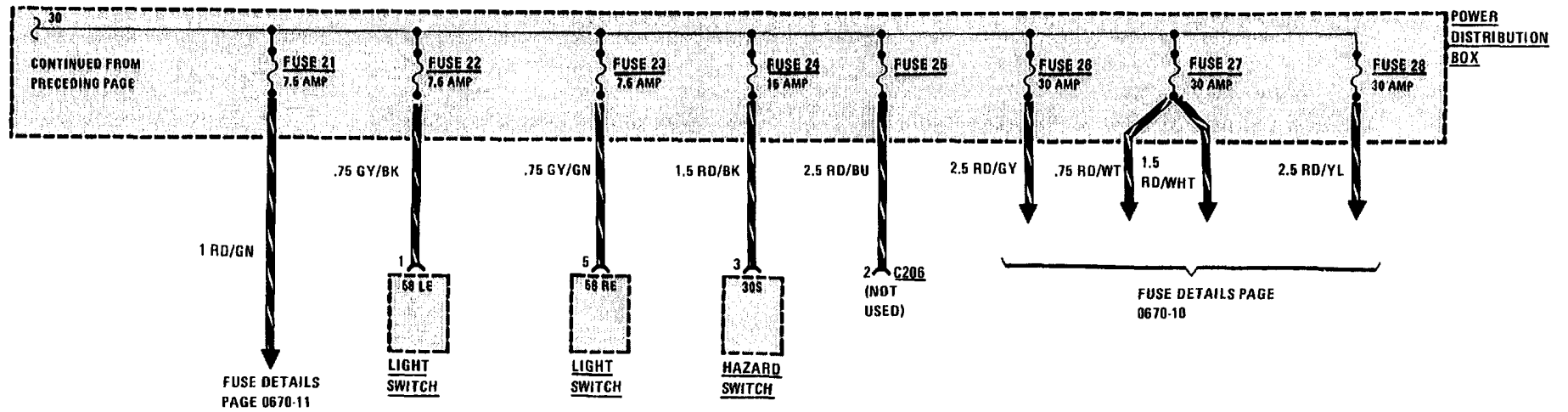

FUSE DETAILS: FUSE 17

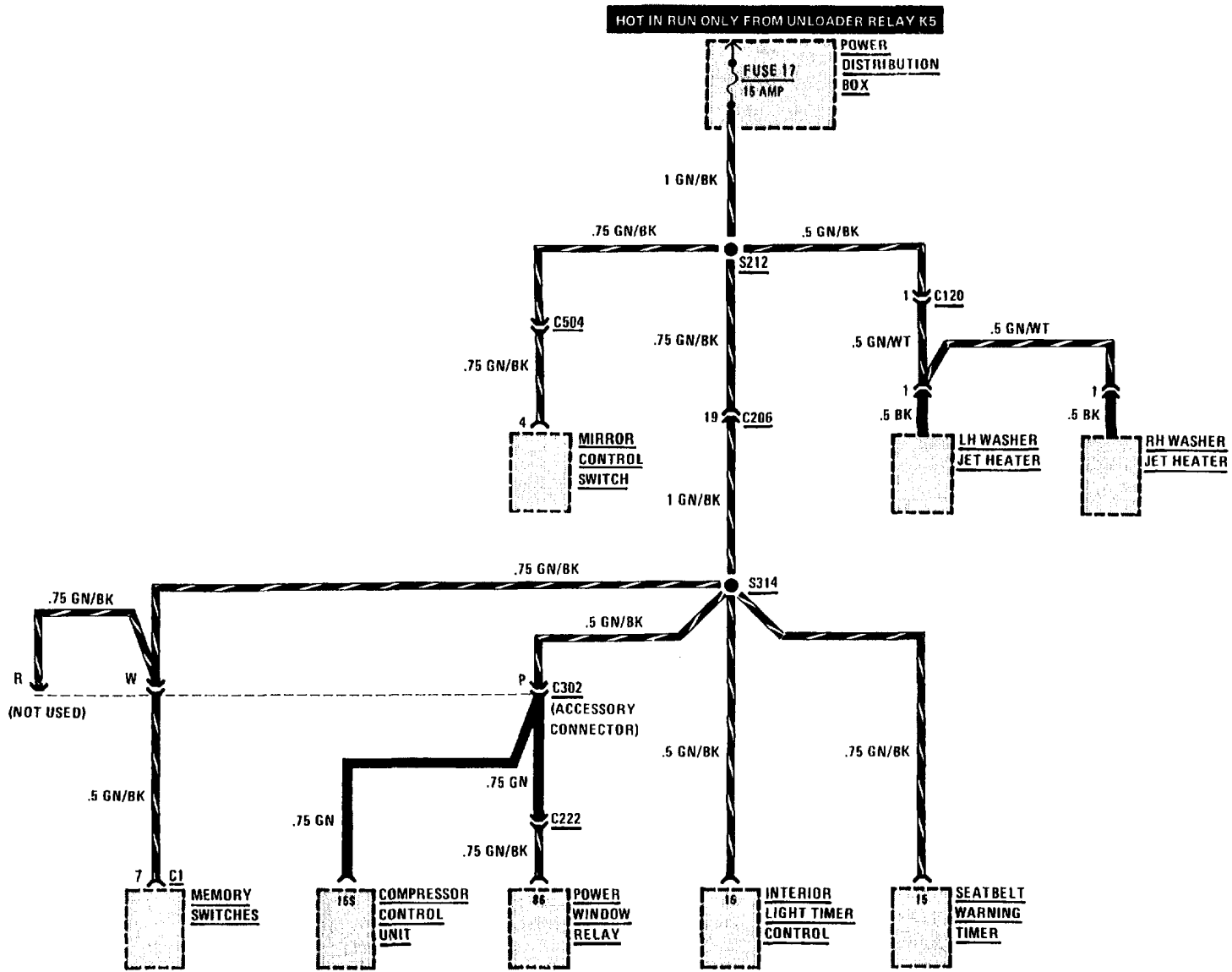

FUSE DETAILS: FUSES 9 AND 16

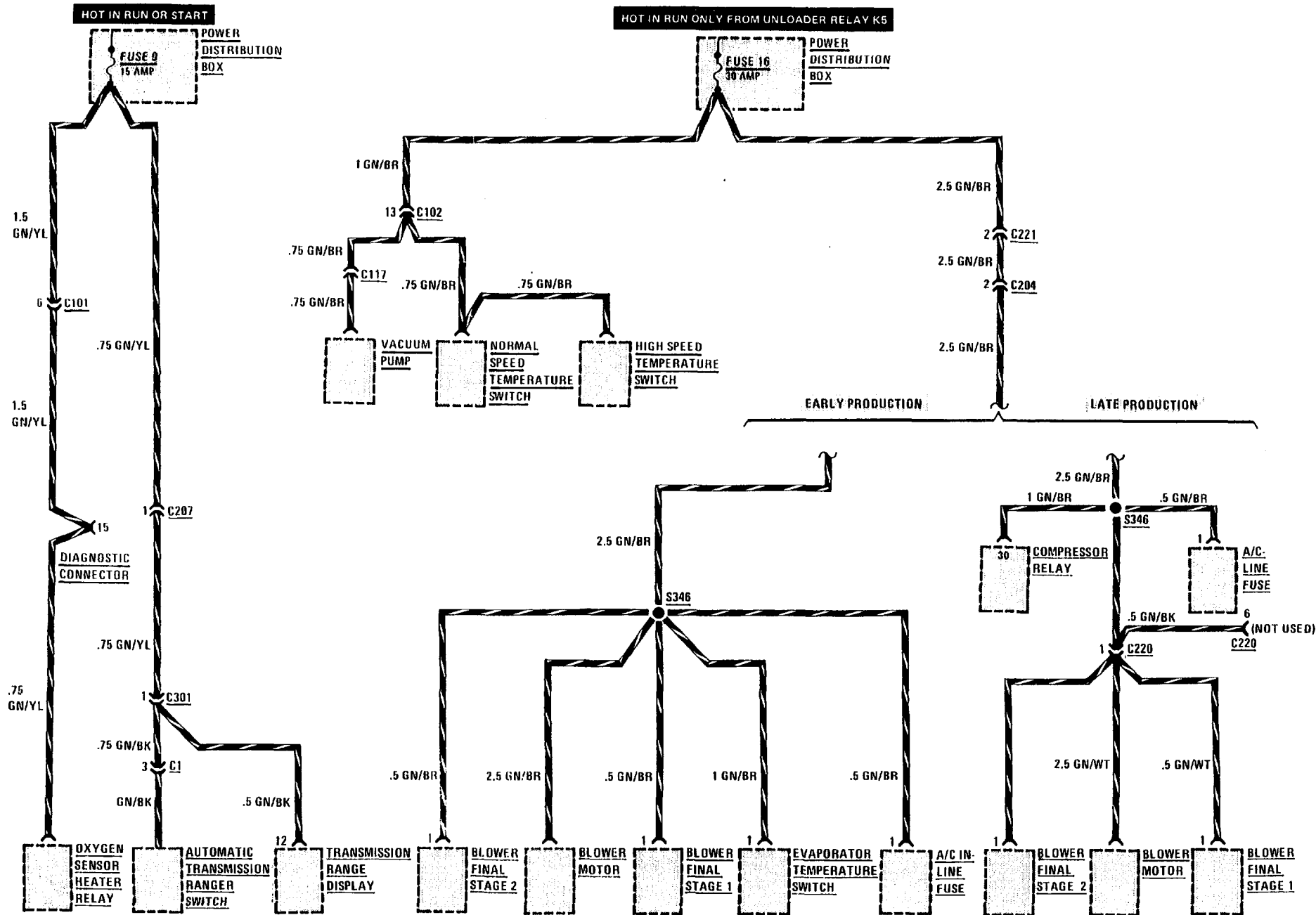

FUSE DETAILS: FUSES 6 AND 12

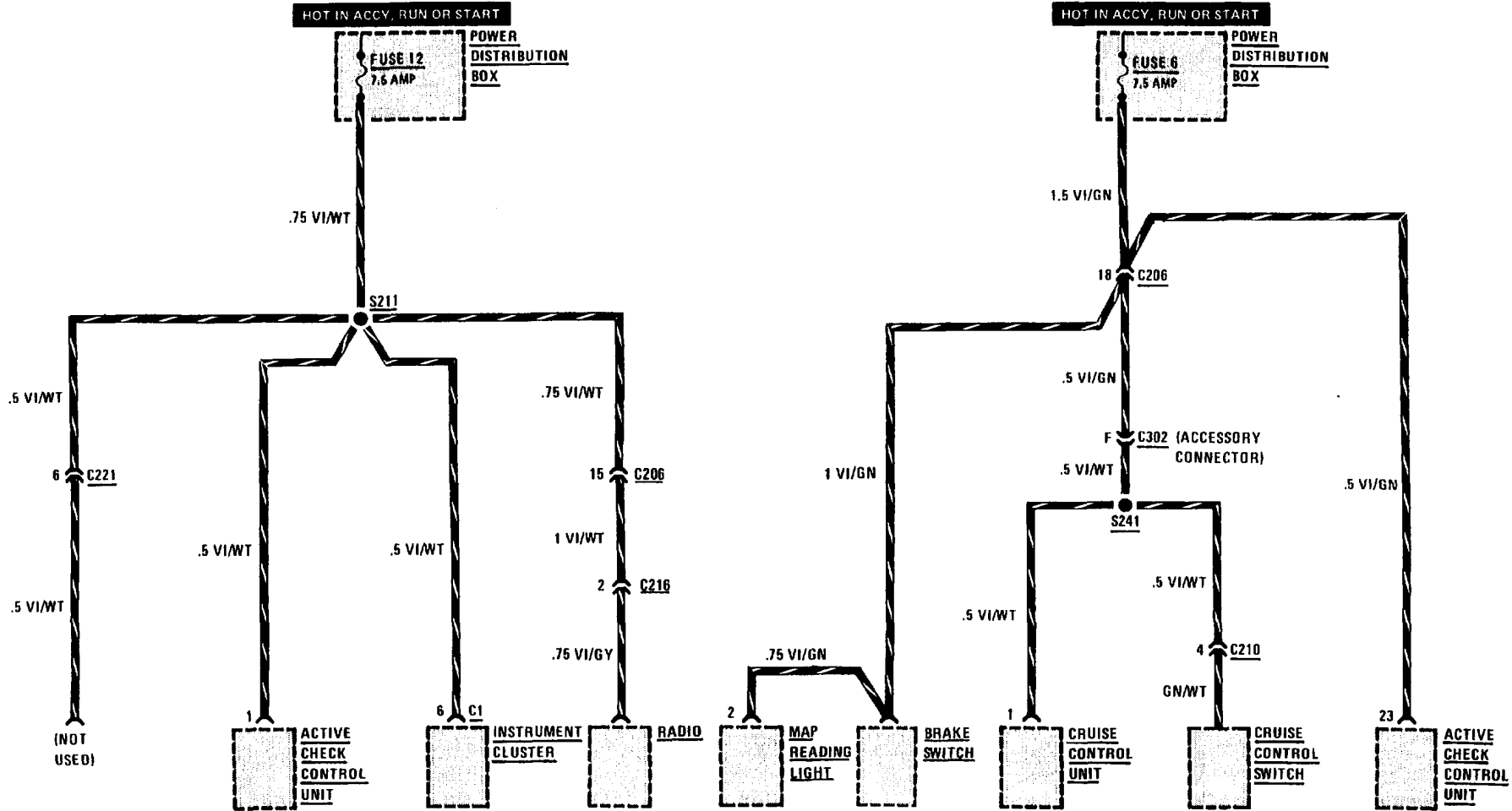

FUSE DETAILS: FUSES 26, 27 AND 28

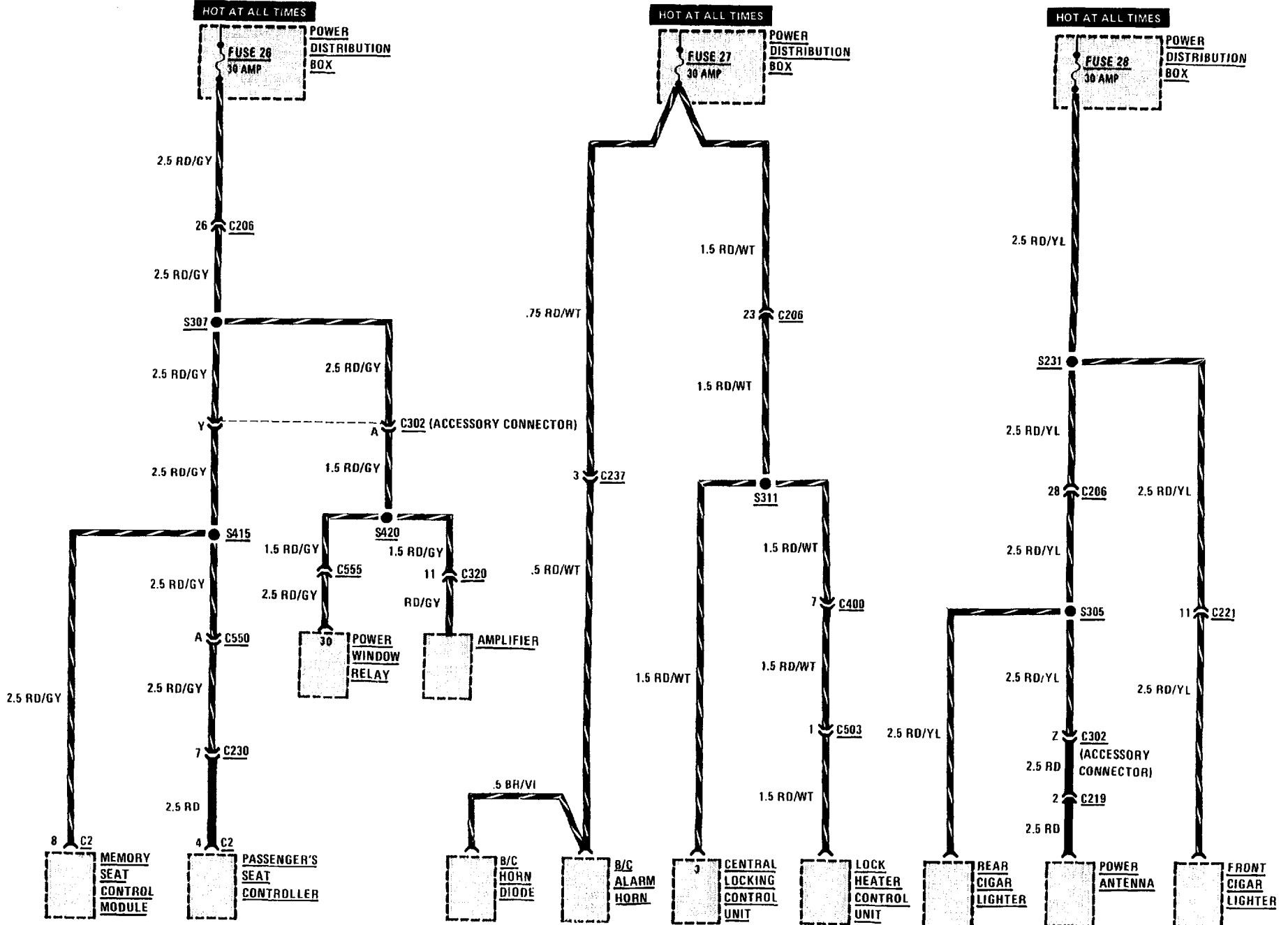

FUSE DETAILS: FUSE 21

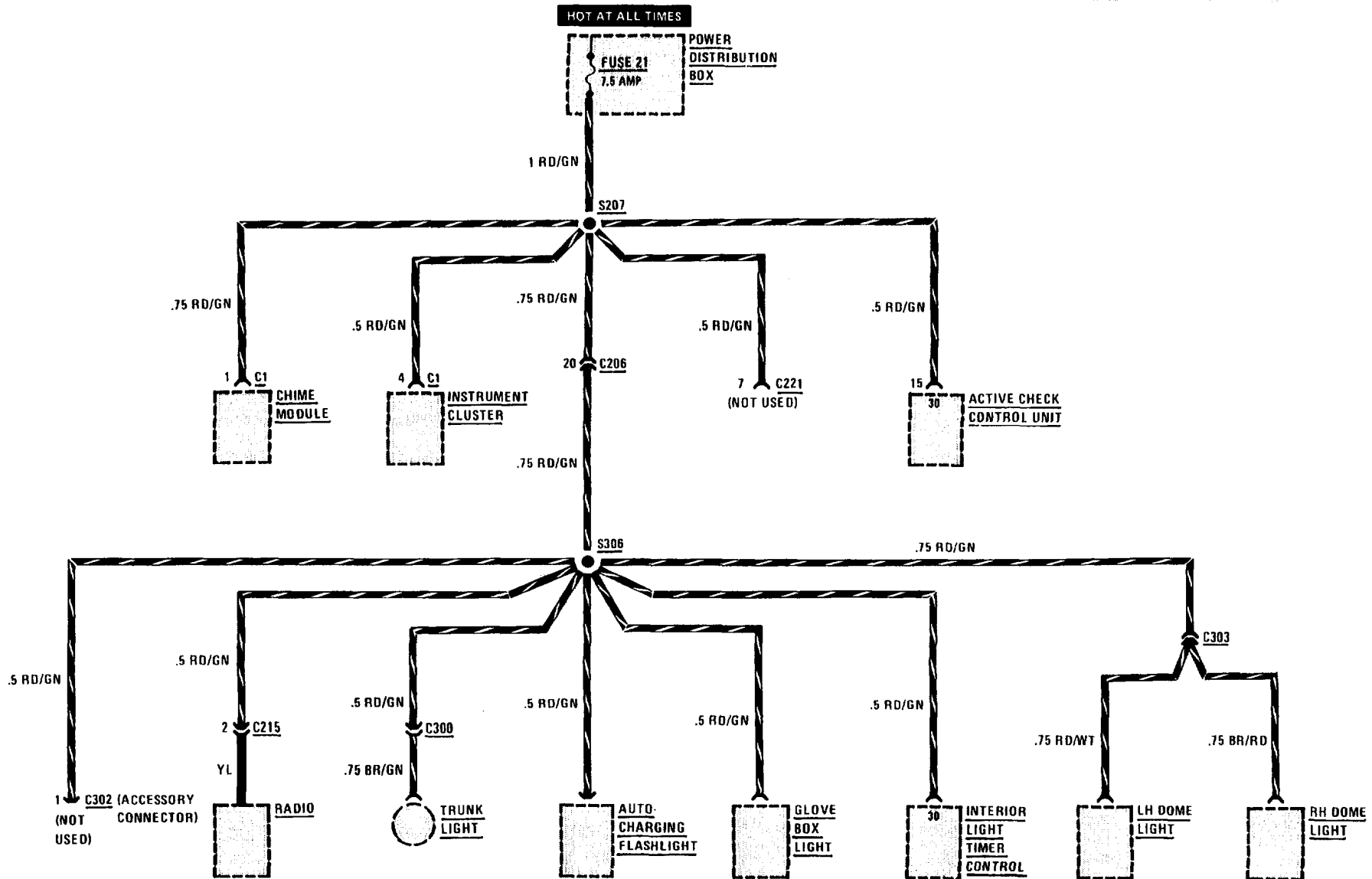

**GROUND DISTRIBUTION (G103, G104)**

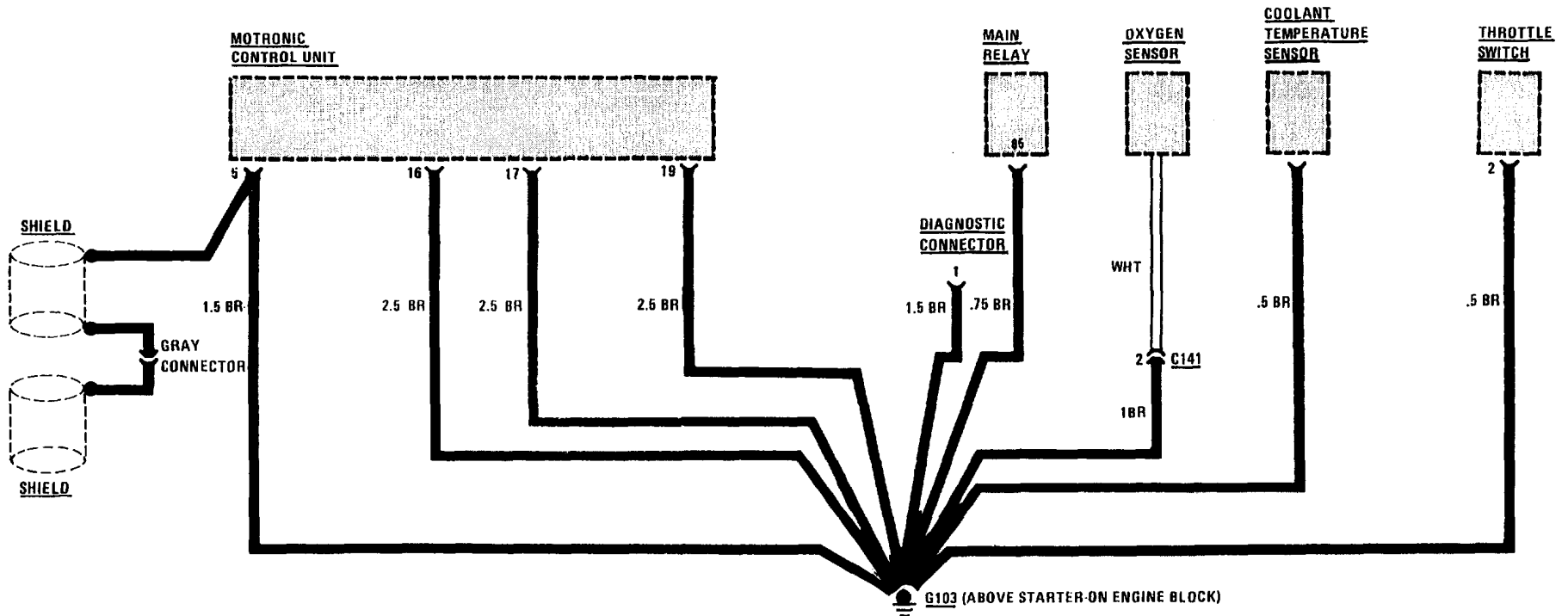
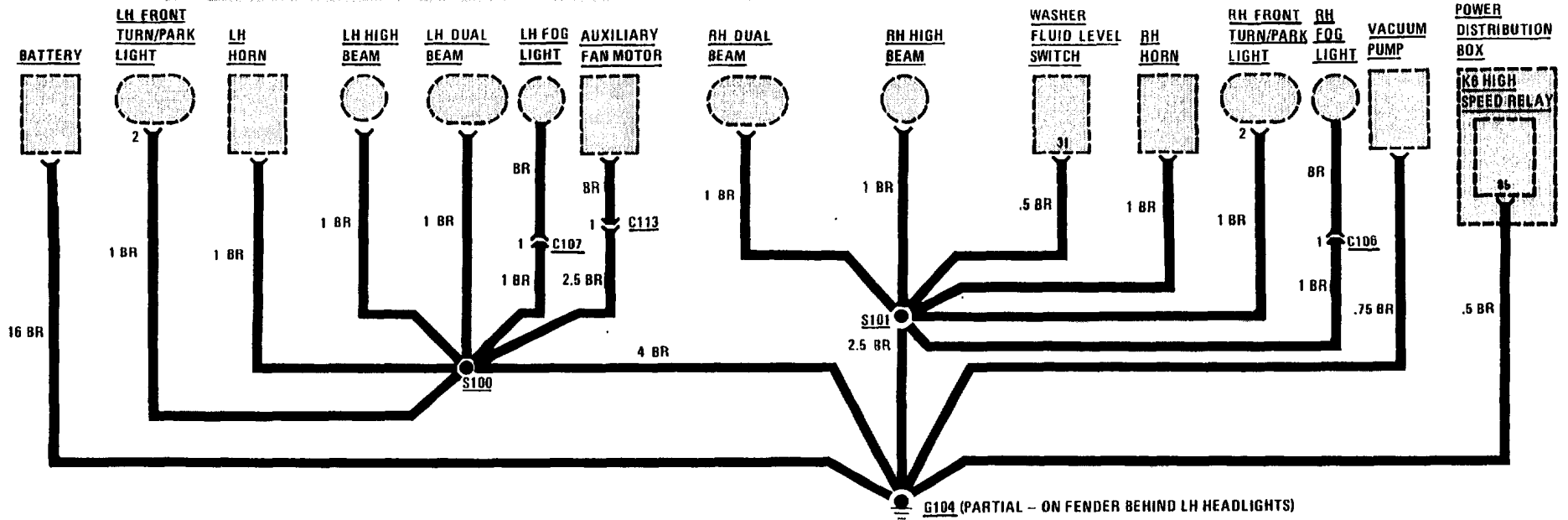

GROUND DISTRIBUTION: G104

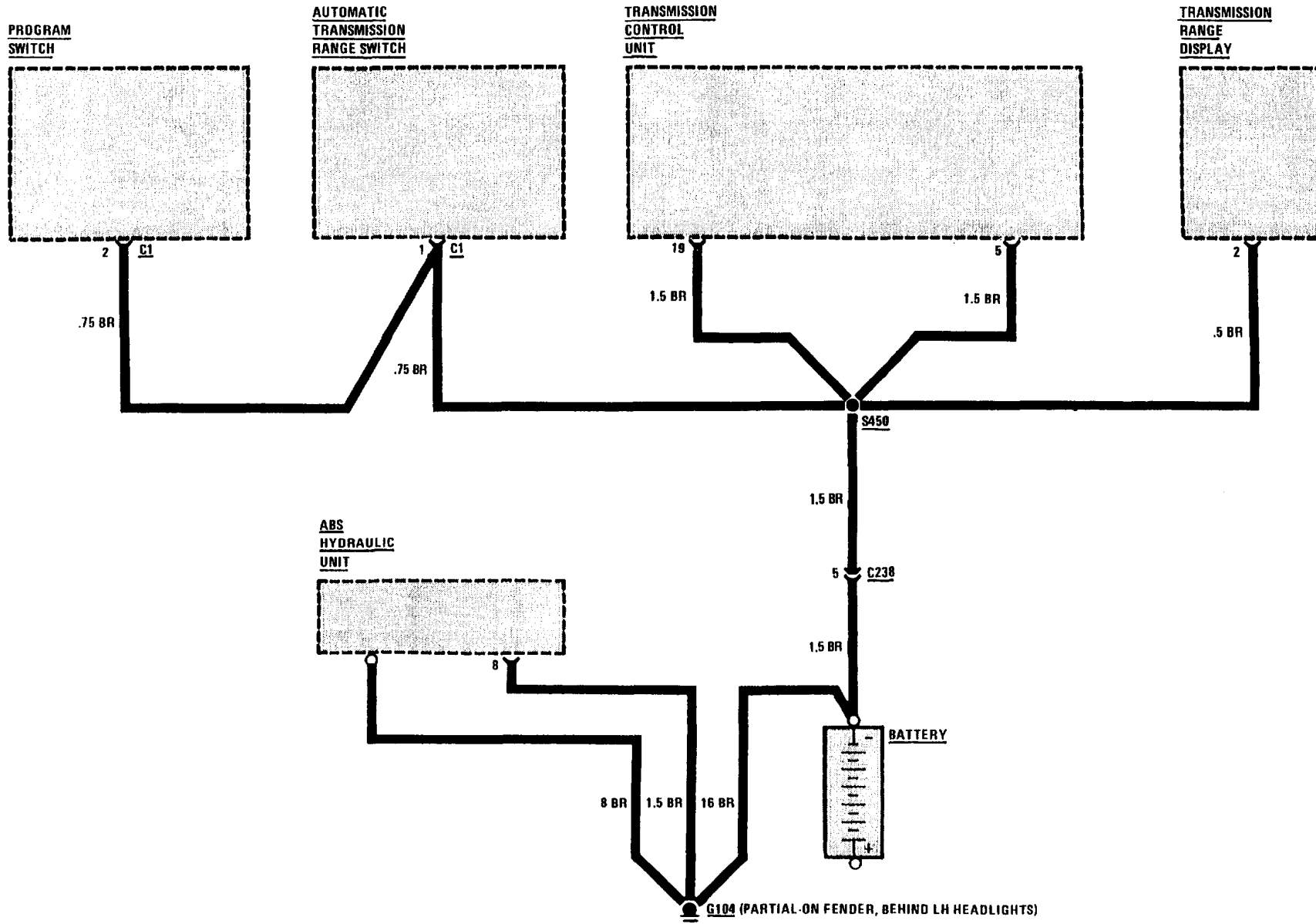



# 0670-14 POWER DISTRIBUTION

## GROUND DISTRIBUTION: G200

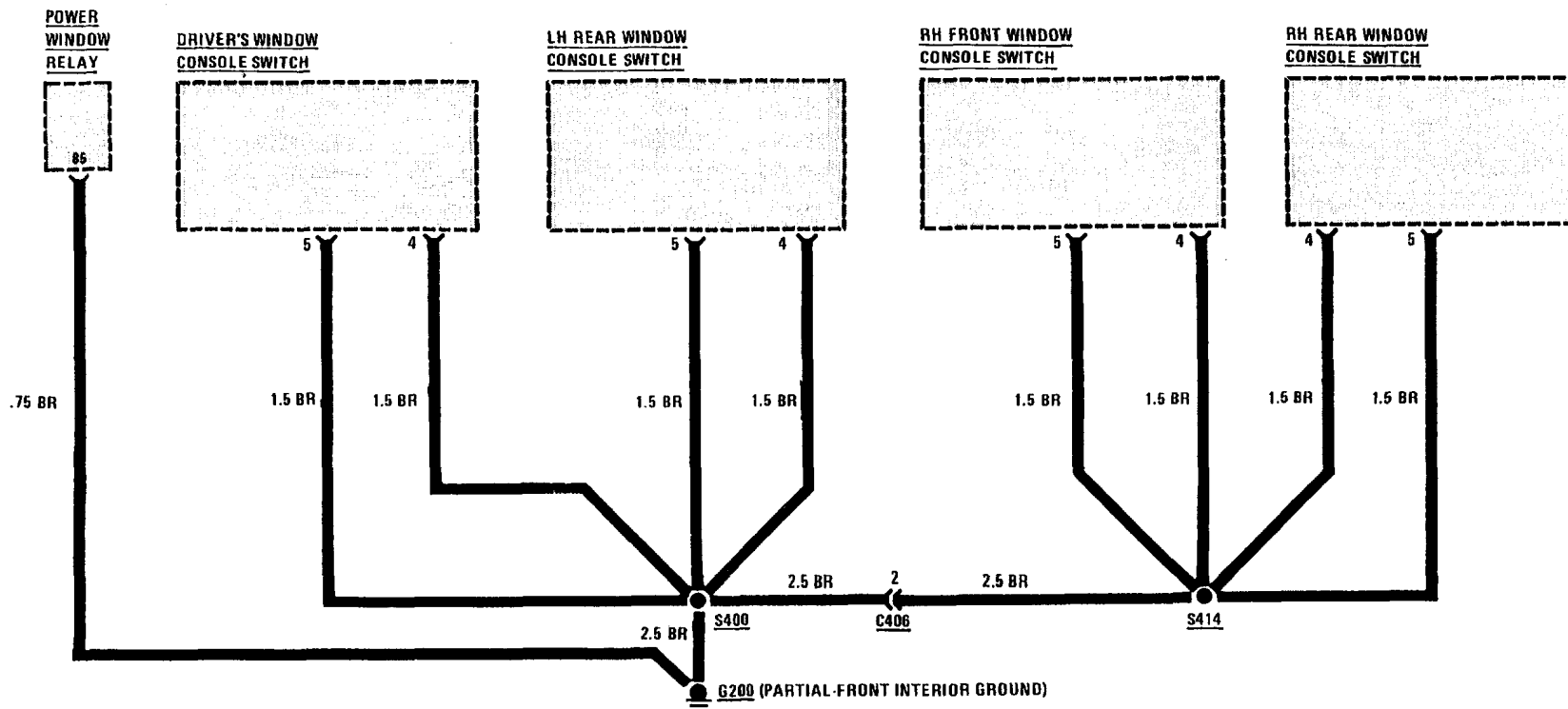
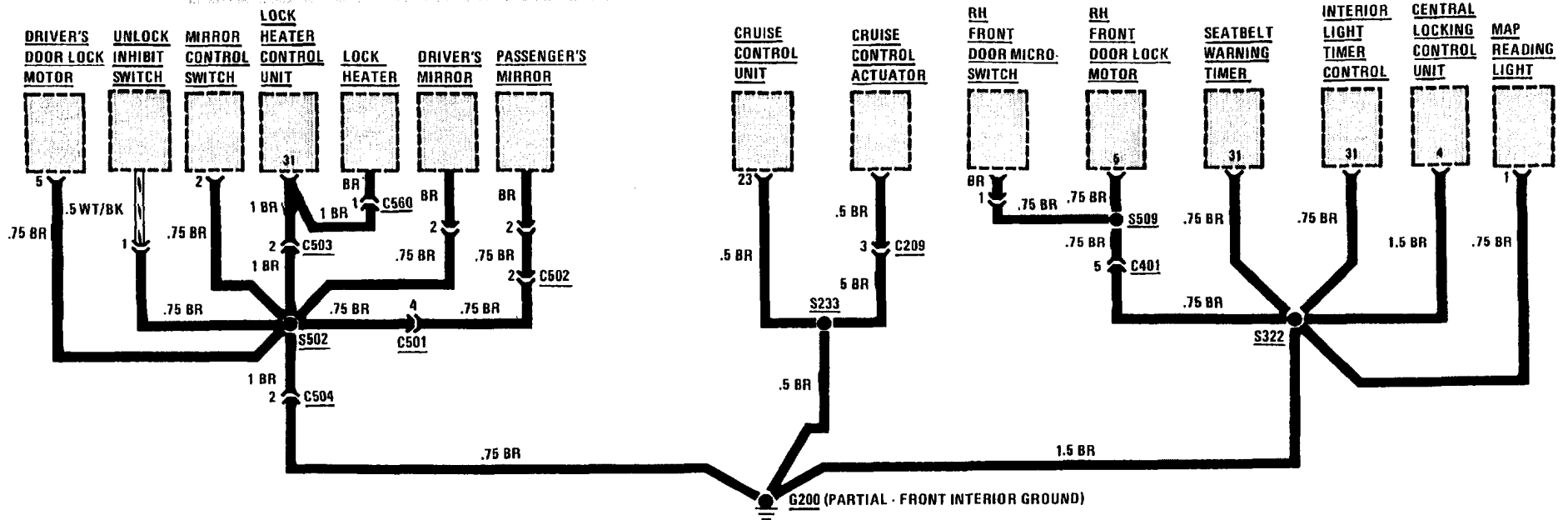

GROUND DISTRIBUTION: G200

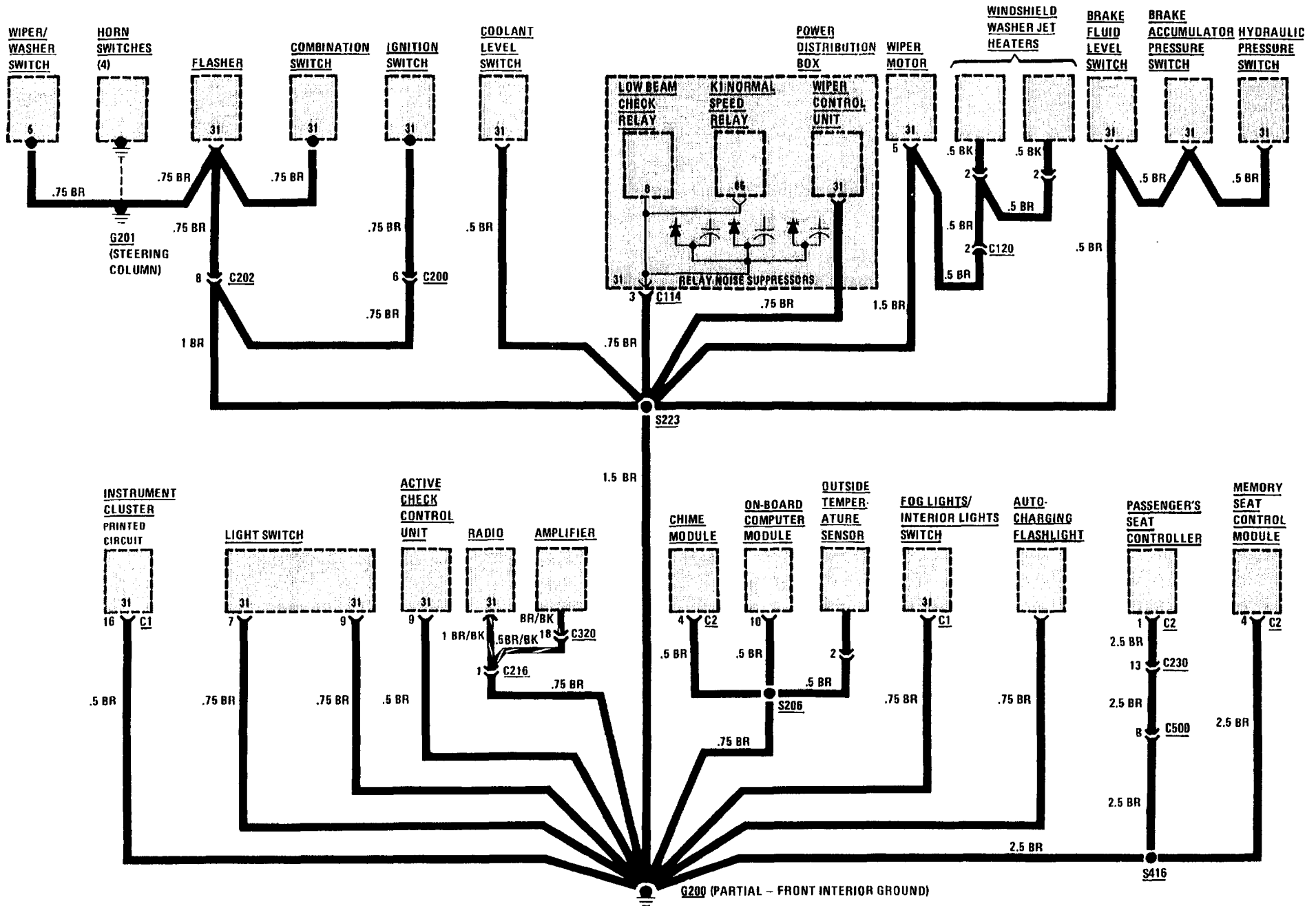

GROUND DISTRIBUTION: G203

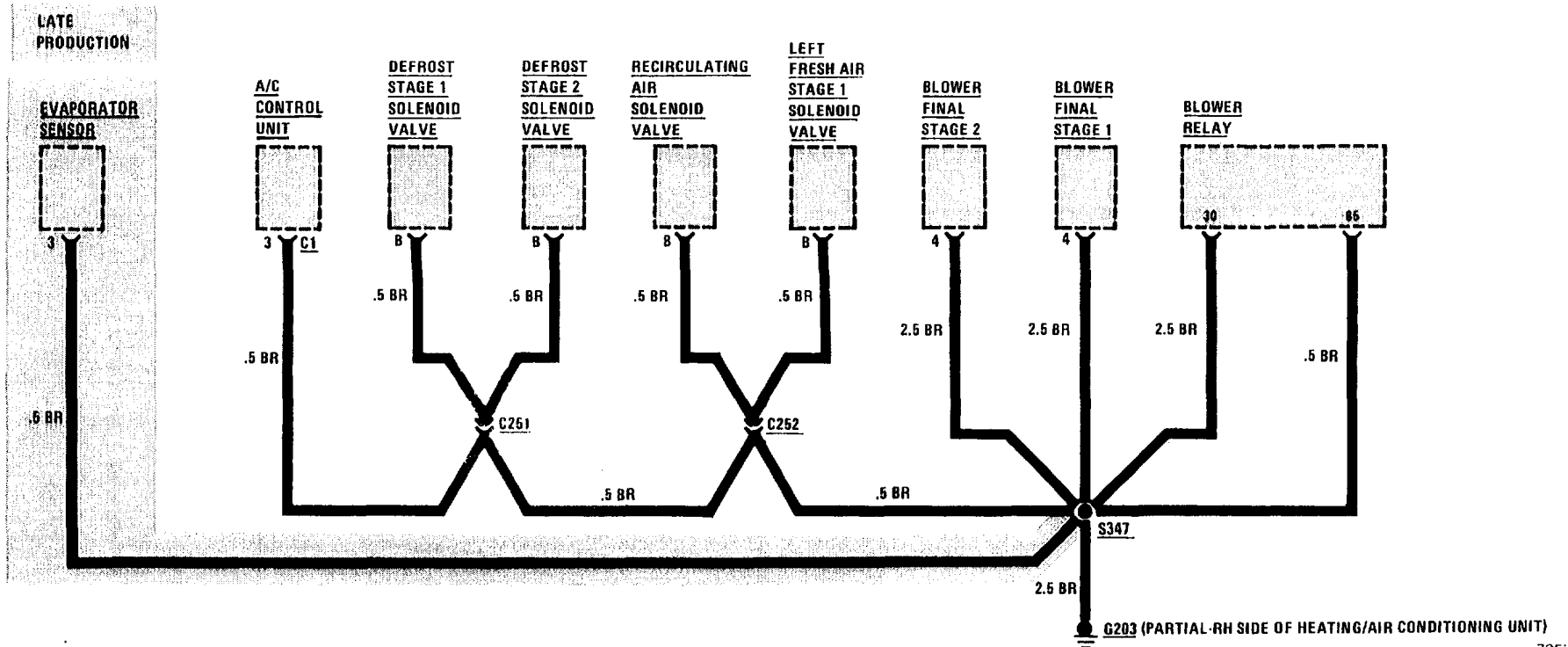
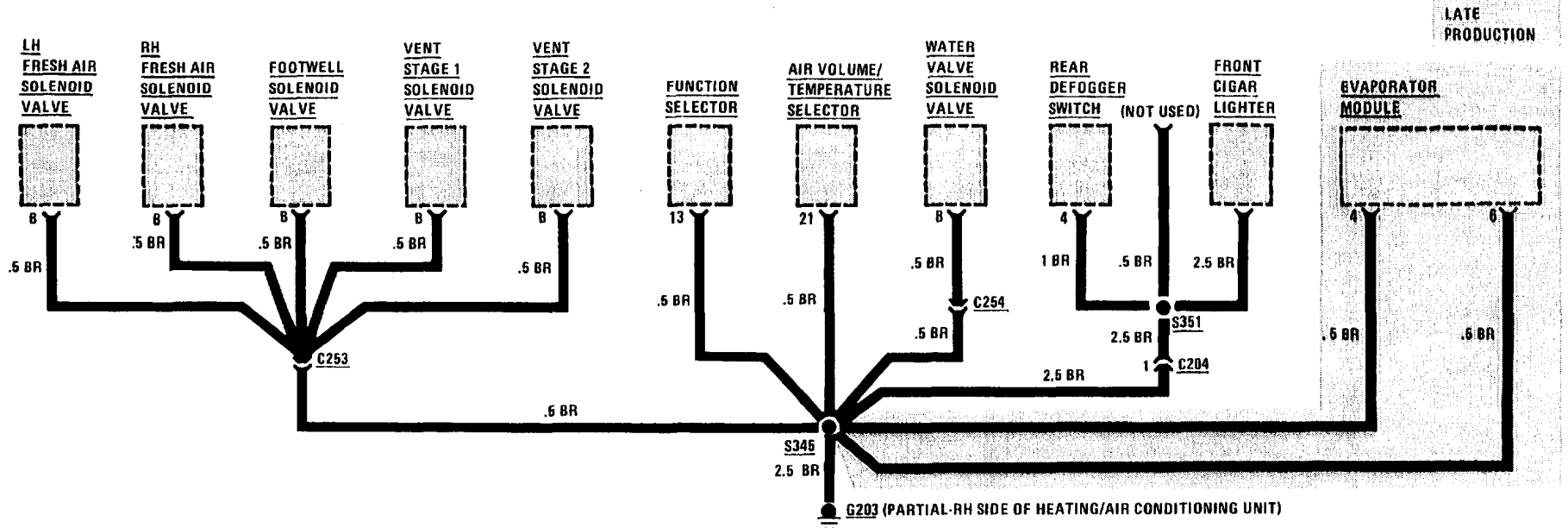

GROUND DISTRIBUTION: G301 AND G302

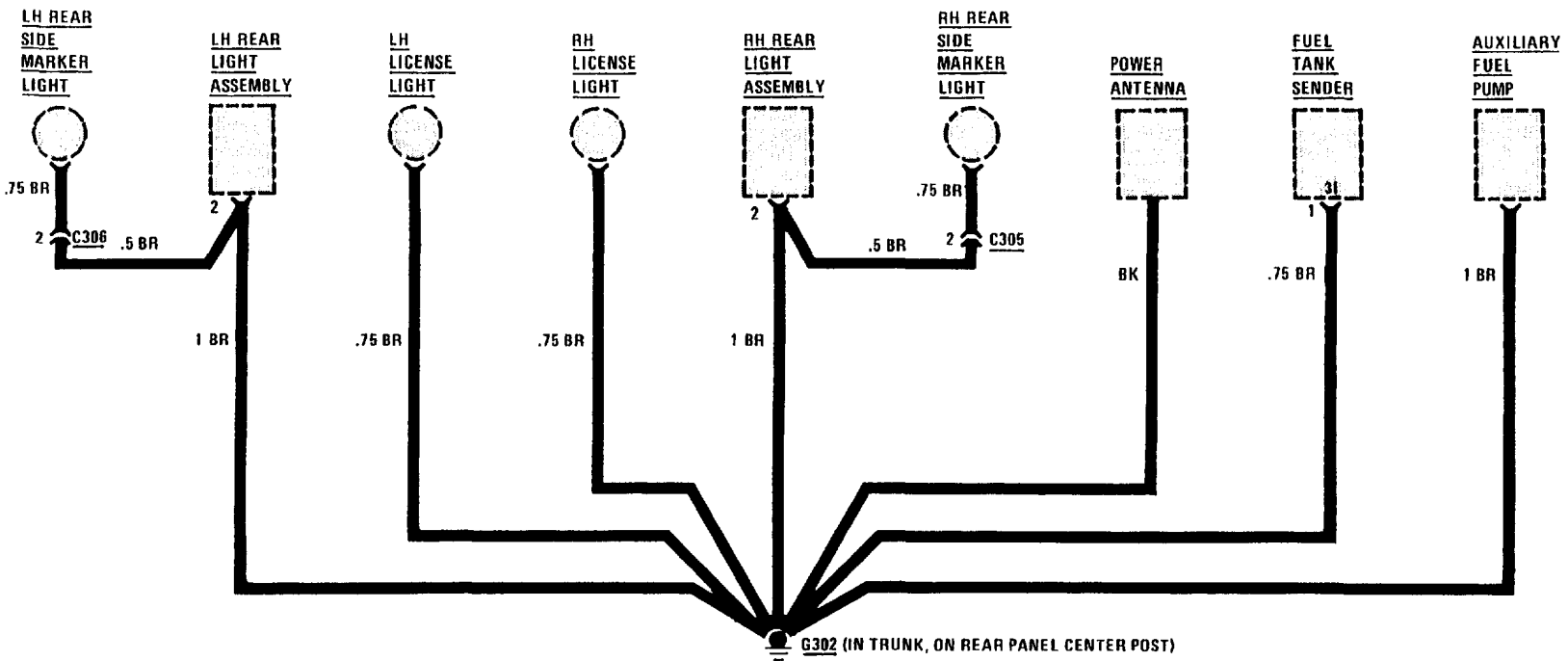
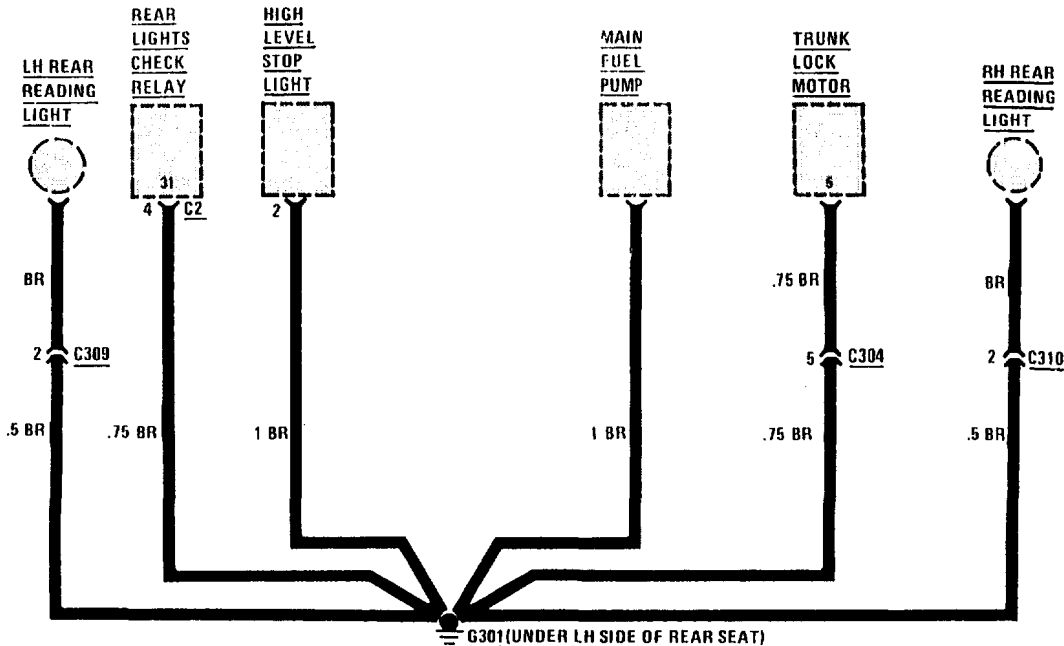



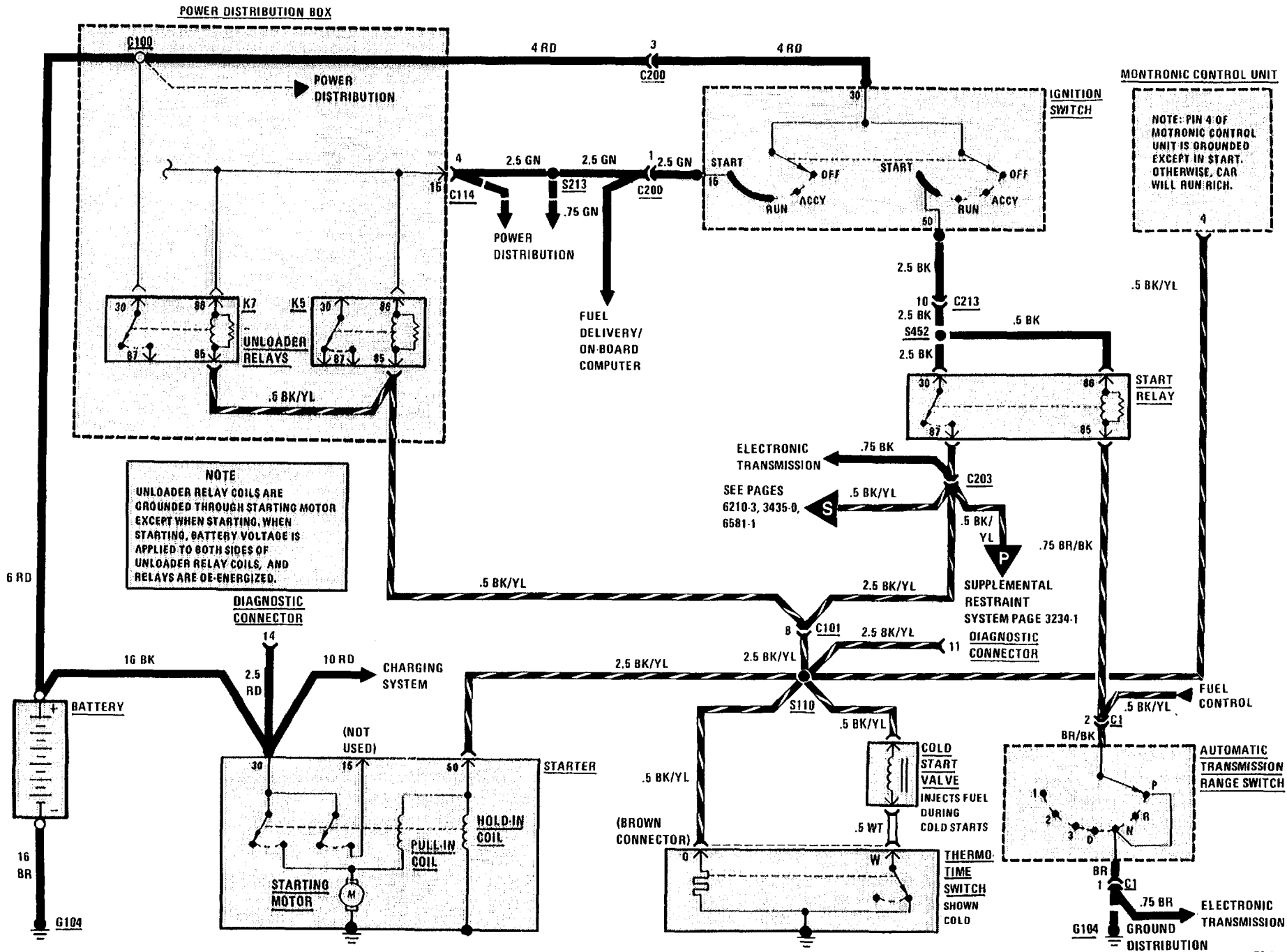

# 1250-0 ENGINE CONTROL BLOCK DIAGRAMS

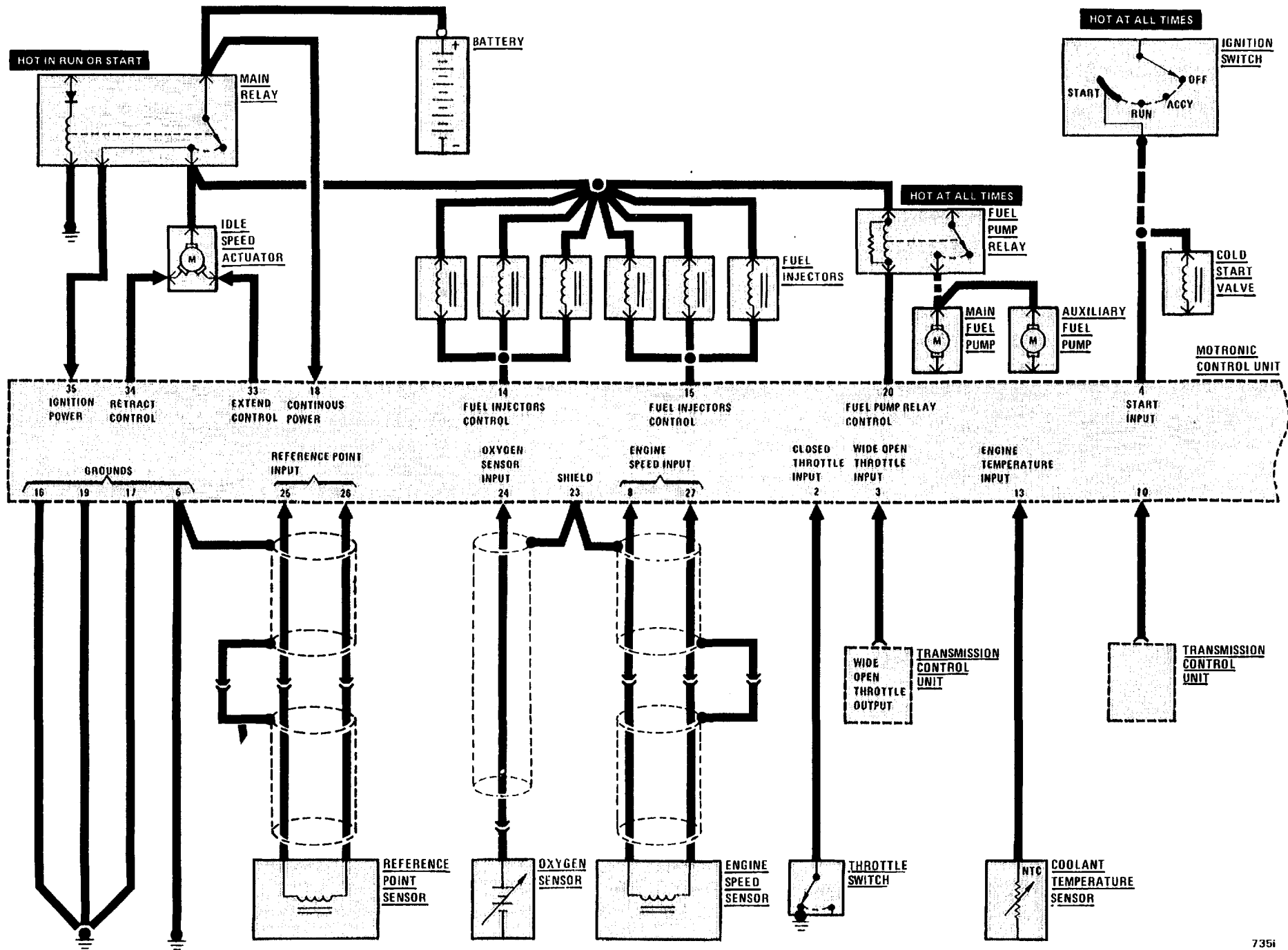

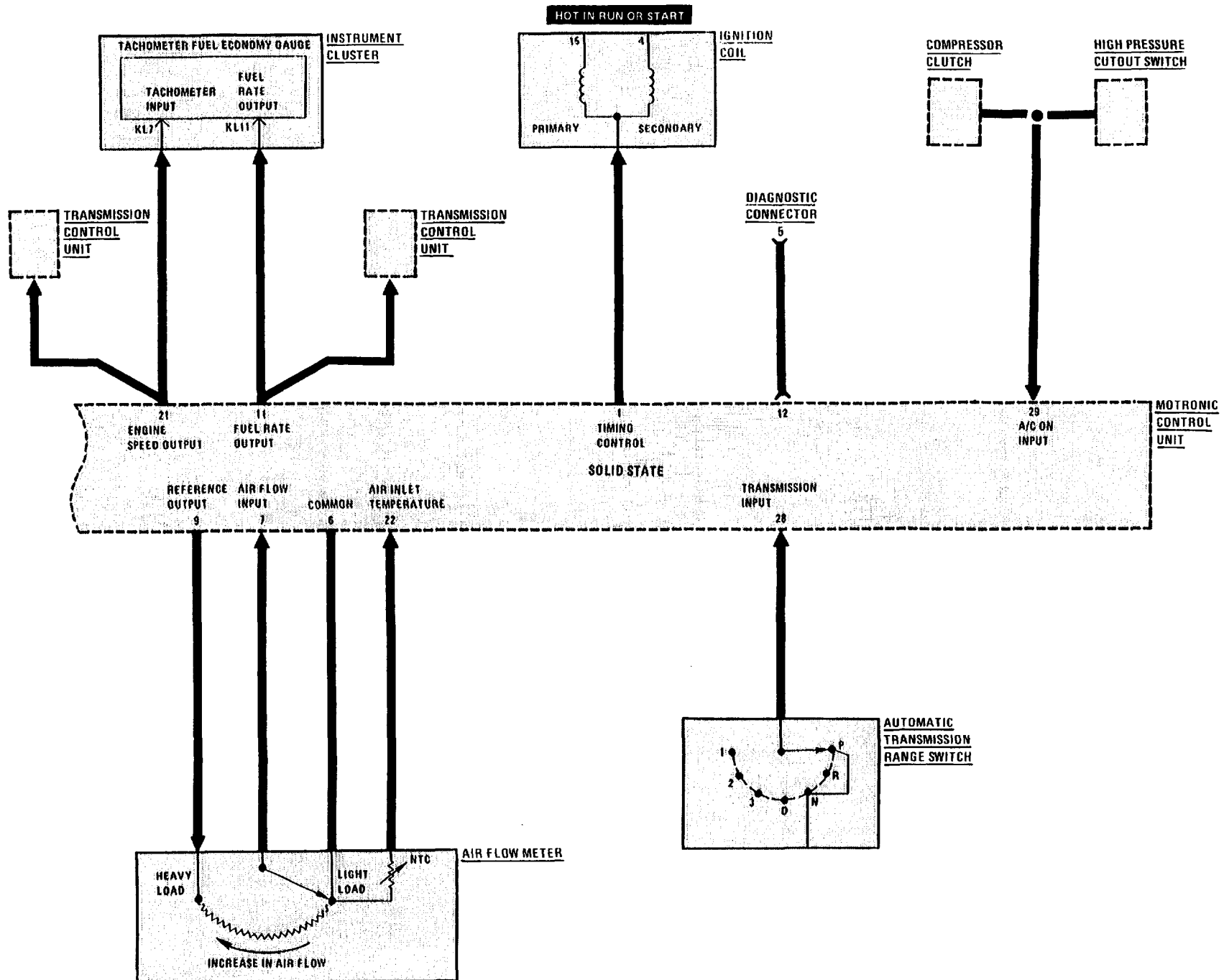



FUEL DELIVERY/FUEL CONTROL/IDLE SPEED CONTROL

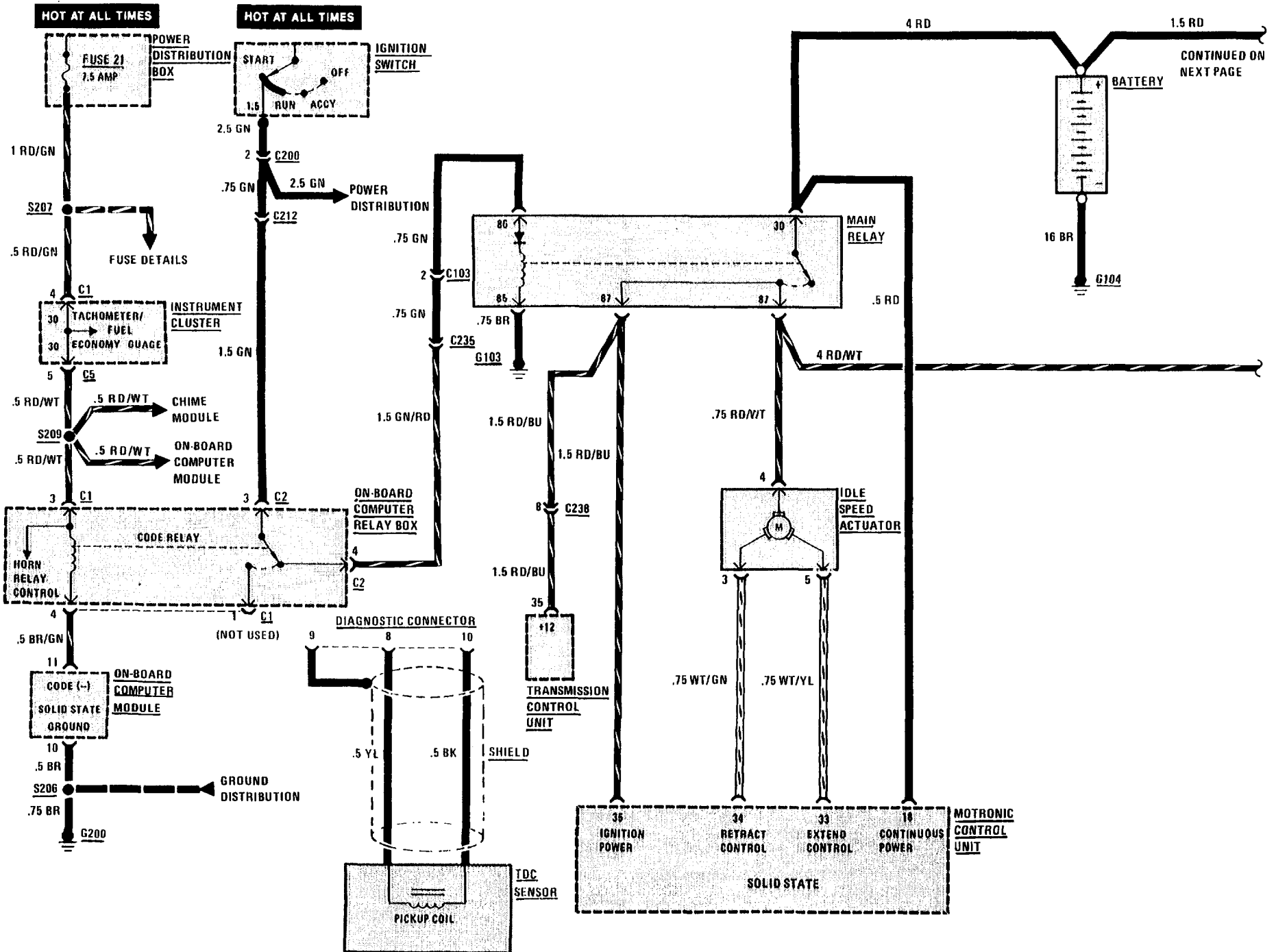

CONTINUED ON NEXT PAGE

FUEL DELIVERY/FUEL CONTROL

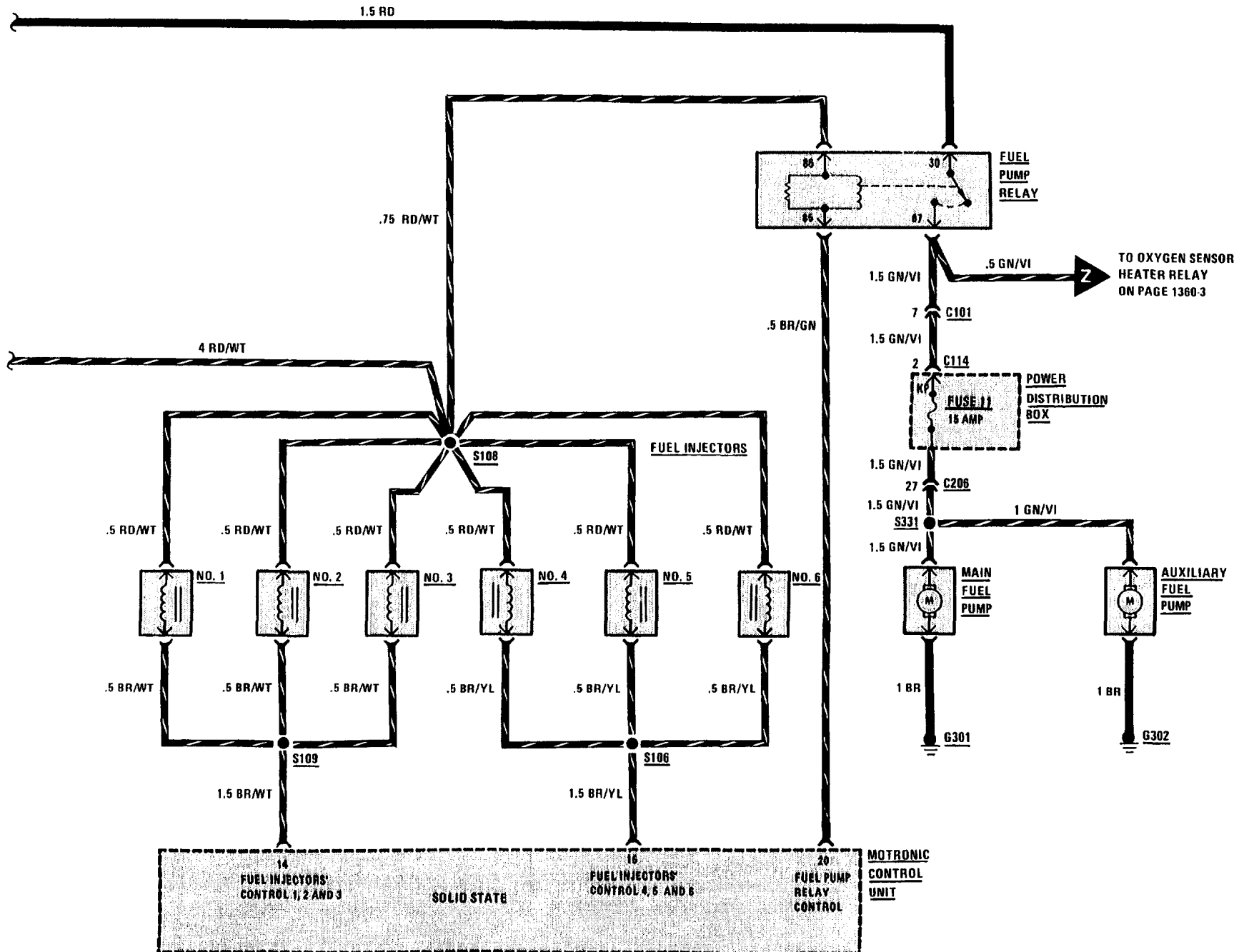

FUEL CONTROL/IGNITION

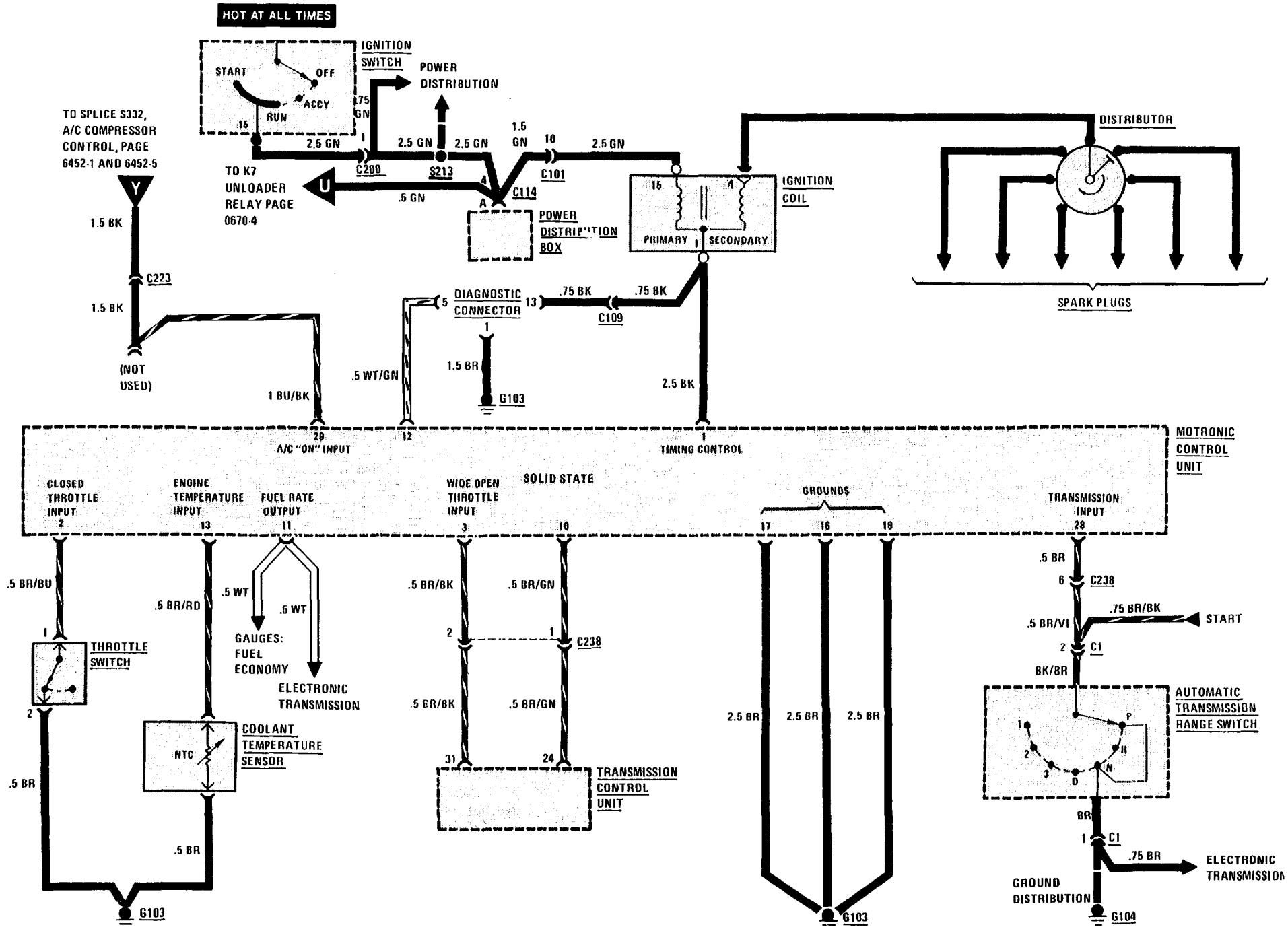

FUEL CONTROL

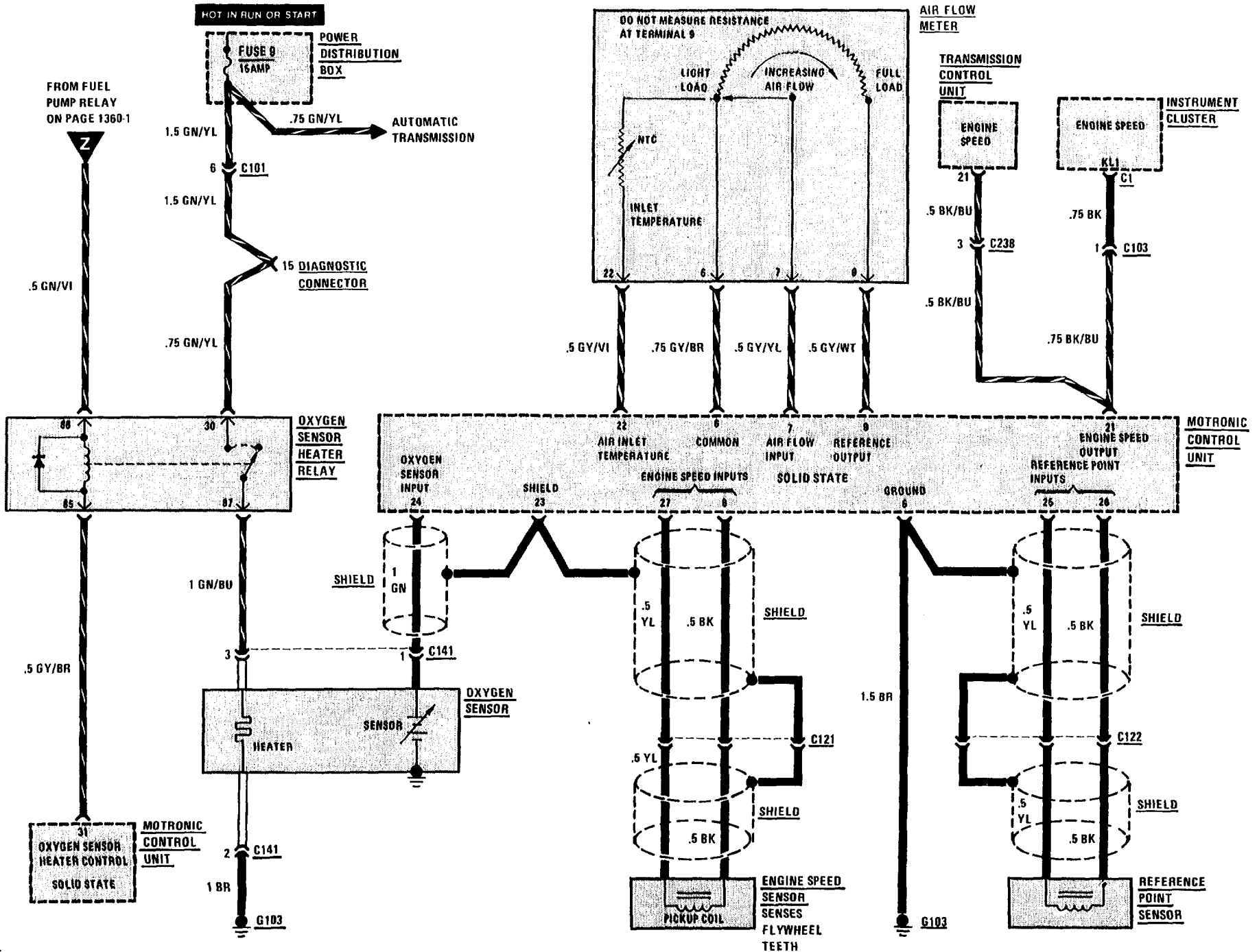

# 2460-0 ELECTRONIC TRANSMISSION CONTROL

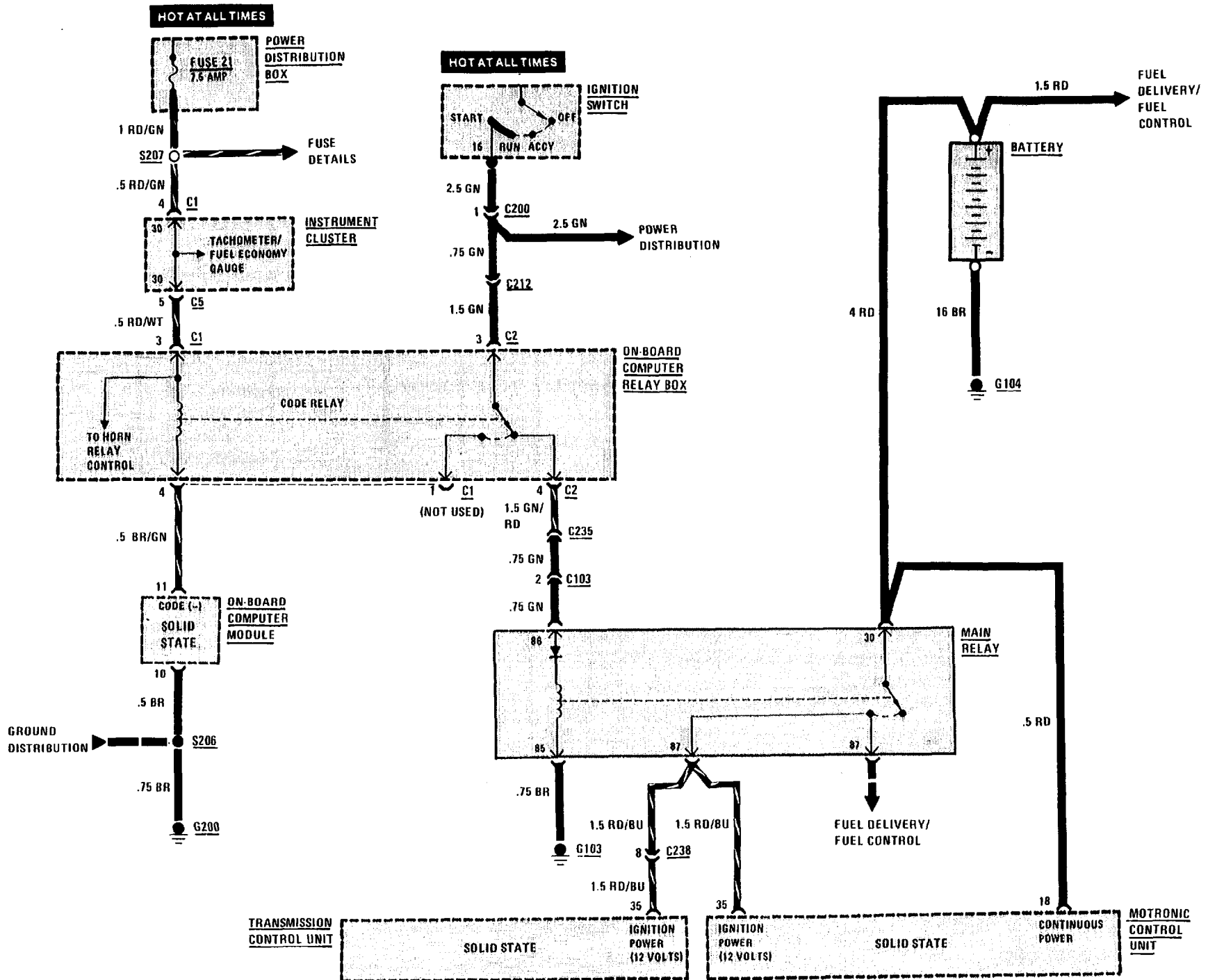

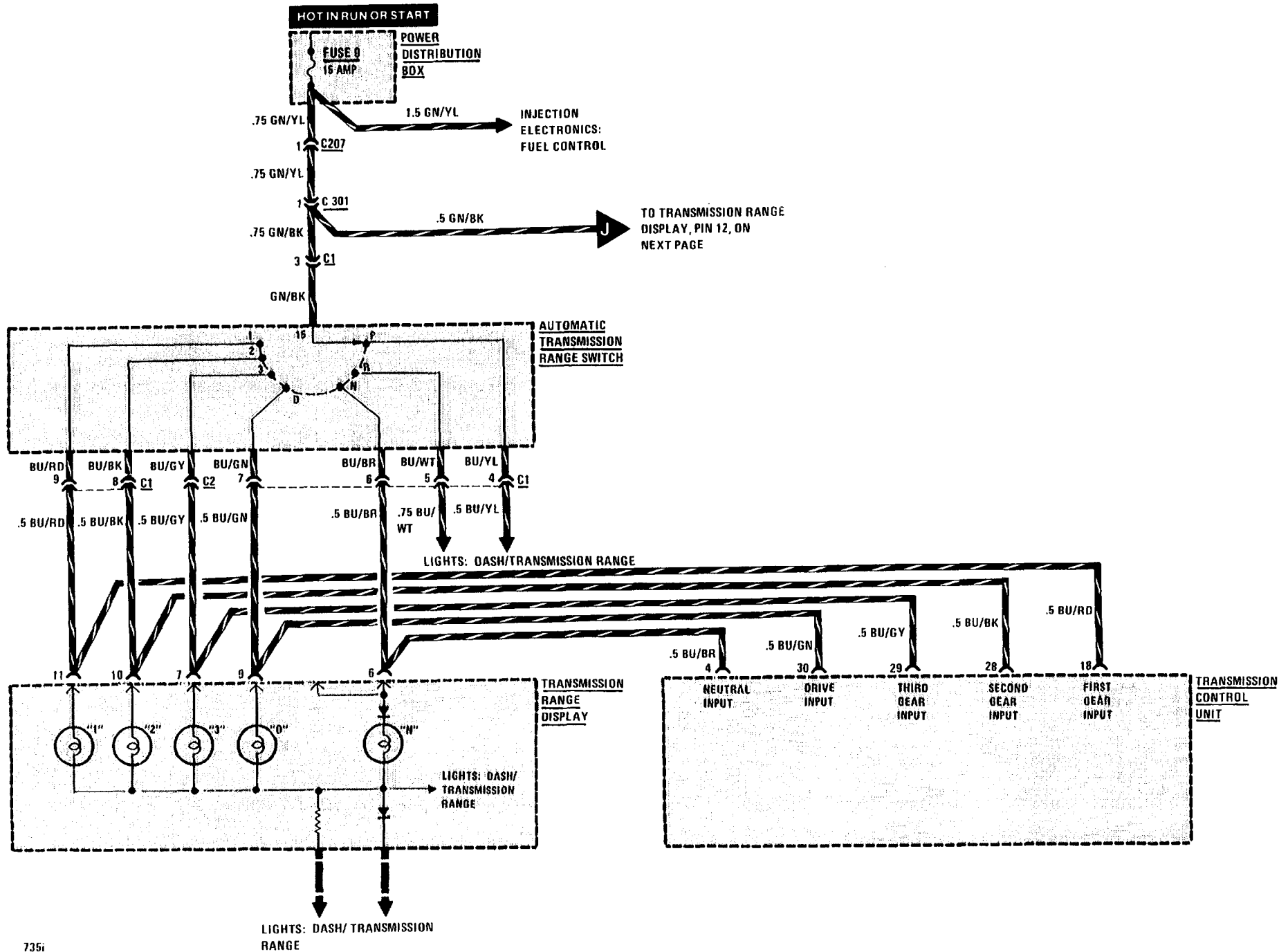

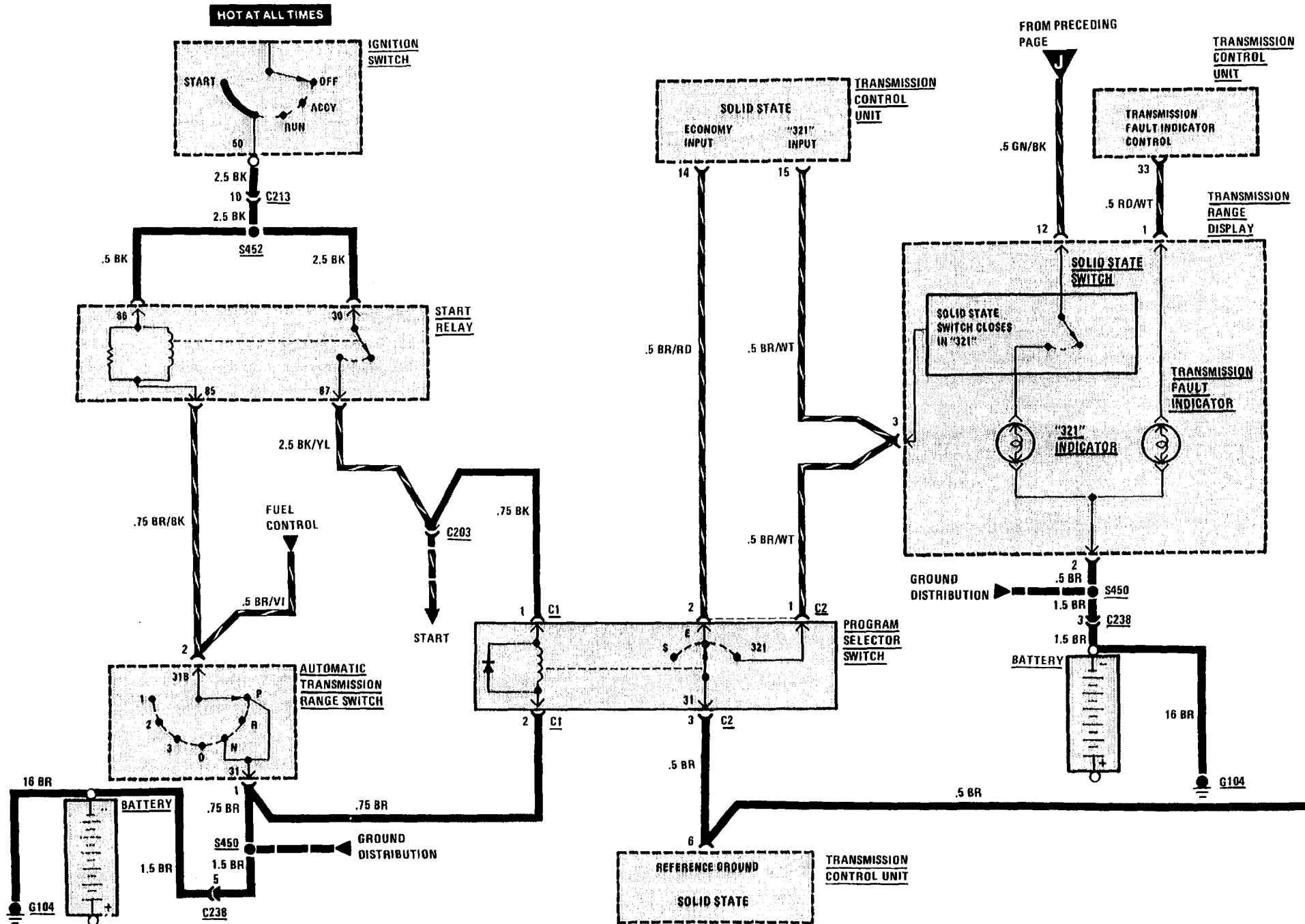

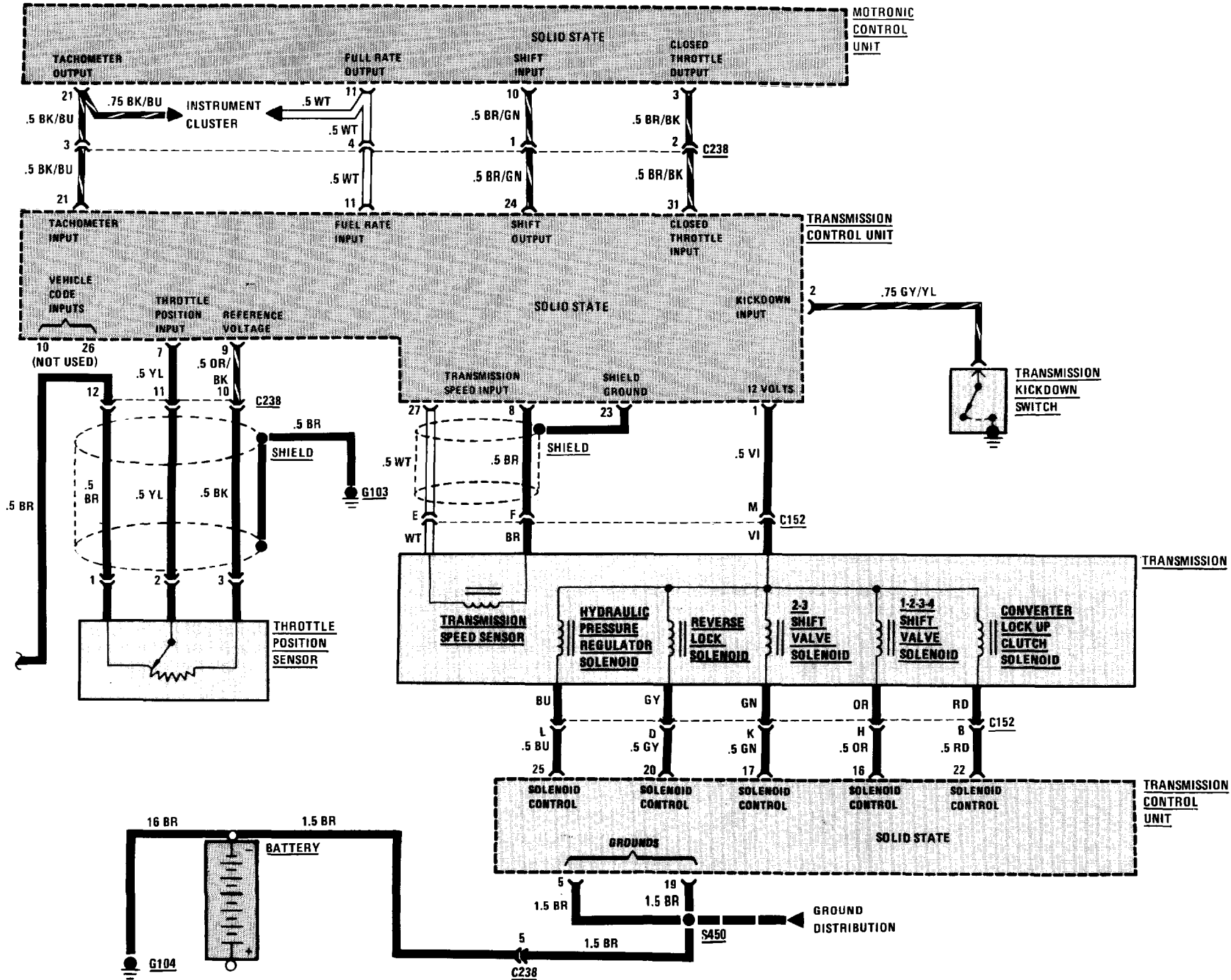



## TROUBLESHOOTING HINTS

- Try the following check before doing the System Check.  
 Check Fuse 9 if all the Transmission Range Display bulbs do not operate.
- Go to System Check for a guide to normal operation.

## SYSTEM CHECK

- Use the System Check Table as a guide to normal operation.
- Refer to System Diagnosis for a list of symptoms and diagnostic steps.

## COMPONENT LOCATION

Page-Figure

Auto. Trans. Range Switch . . . . .	Below console, on base of shift lever . . . . .	7000- 9-5
Kickdown Switch . . . . .	Below accelerator pedal	
Main Relay . . . . .	Behind right front shock tower . . . . .	7000- 7-1
Motronic Control Unit . . . . .	Behind right front speaker . . . . .	7000- 9-6
Power Distribution Box . . . . .	Top front of left front wheel well . . . . .	7000- 4-5
Throttle Position Sensor . . . . .	Top of engine	
Transmission Control Unit . . . . .	Behind left front speaker . . . . .	7000- 9-4
C152 (8 pin) . . . . .	Near transmission	
C207 (2 pin) . . . . .	Under LH side of dash near body electrical bracket . . . . .	7000- 8-4
C238 (13 pin) . . . . .	Behind right front speaker . . . . .	7000- 9-6
C301 (2 pin) . . . . .	In center console, ahead of shift lever . . . . .	7000- 9-5
G104 (Main Body Ground) . . . . .	On power distribution box bracket . . . . .	7000- 4-5

## SYSTEM CHECK TABLE

ACTION	NORMAL OPERATION
Turn the Ignition Switch to RUN.	The Transmission Fault Indicator flashes twice, then stays on.
Set the Program Selector Switch to 321.	The 321 Indicator lights.
Crank the engine.	The Program Selector Switch returns to E.
Start the engine.	The Transmission Fault Indicator goes out with the engine running.
Drive the car with the Program Selector Switch in 321.	The car operates in selected gear only (first, second, or third gear).

Drive the car with the Program Selector Switch in S.	First, second, and third gears are kept selected up to full engine speed. Fourth gear (overdrive) is not selected.
Drive the car with the Program Selector Switch in E.	Transmission shifts at lower engine speeds and a fourth gear (overdrive) is available.

- Refer to System Diagnosis when a result is not normal.

## SYSTEM DIAGNOSIS

- Do the tests listed for your symptom in the Symptom Table below.
- Tests follow the Symptom Table.

**SYMPTOM TABLE**

SYMPTOM	DO TEST
Transmission Fault Indicator does not flash when the Ignition Switch is turned to RUN and lights when the engine is running.	A: Transmission Control Unit 5 Volt Power and Ground Test.
Transmission Fault Indicator flashes when the Ignition Switch is turned to RUN and lights with the engine running.	C: Engine Speed and Fuel Rate Input Test. D: Hydraulic Pressure Regulator and Solenoid Test.
Transmission Fault Indicator does not light with the Ignition Switch in RUN and the engine not running.	B: Transmission Control Unit Ignition Power Test. G: Transmission Fault Indicator Test.
Program Selector Switch does not return to E when the engine is cranked.	F: Program Selector Switch Return Test.
321 Indicator does not light when the Program Selector Switch is set to 321, but Transmission operates in the 321 mode.	H: 321 Indicator Test.
Transmission does not operate in selected program and the Transmission Fault Indicator is off with the engine running.	I: Program Selector Switch Continuity Test.

Kickdown function is inoperative.	K: Kickdown Switch Test.
Shift Points are inaccurate or rough and the Transmission Fault Indicator is off with the engine running.	L: Gear Input Test. M: Throttle Position Sensor and Wide Open Throttle Output Test. J: Transmission Speed Sensor Test.

**NOTE:** The Transmission Control Unit is located behind the speaker cover in the left A pillar. This requires removing the speaker cover and the speaker connectors. Remove the Transmission Control Unit from A pillar. Then remove screw from the connector cover and slide off to facilitate measurements.

**A: TRANSMISSION CONTROL UNIT 5 VOLT POWER AND GROUND TEST**

<b>Measure: VOLTAGE</b>		
<b>At: TRANSMISSION CONTROL UNIT CONNECTOR (Connected)</b>		
<b>Condition:</b> • Ignition Switch: RUN		
Measure Between	Correct Voltage	For Diagnosis
24 (BR/GN) & Ground	Approximately 5 Volts	See 1
24 (BR/GN) & 19 (BR)	Approximately 5 Volts	See 2
24 (BR/GN) & 5 (BR)	Approximately 5 Volts	See 2
<ul style="list-style-type: none"> <li>If all the results are correct, replace the Transmission Control Unit.</li> </ul>		
<ol style="list-style-type: none"> <li>Go to Test E: Motronic Control Unit Test.</li> <li>Check/repair the BR wire for an open (see schematic).</li> </ol>		

**B: TRANSMISSION CONTROL UNIT IGNITION POWER TEST**

<b>Measure: VOLTAGE</b>		
<b>At: TRANSMISSION CONTROL UNIT CONNECTOR (Connected)</b>		
<b>Condition:</b> • Ignition Switch: RUN		
Measure Between	Correct Voltage	For Diagnosis
35 (RD/BU) & Ground	Battery	See 1
<ul style="list-style-type: none"> <li>If the result is correct, go to the Symptom Table.</li> </ul> <ol style="list-style-type: none"> <li>Check/repair the RD/BU wire to the Main Relay for an open (see schematic).</li> </ol>		

**C: ENGINE SPEED AND FUEL RATE INPUT TEST**

<b>Measure: VOLTAGE</b>		
<b>At: TRANSMISSION CONTROL UNIT CONNECTOR (Connected)</b>		
<b>Condition:</b> • Ignition Switch: RUN		
Measure Between	Correct Voltage	For Diagnosis
11 (WT) & Ground	Greater than 10 Volts	See 1
21 (BK/BU) & Ground	Greater than 10 Volts	See 2
<ul style="list-style-type: none"> <li>If all the results are correct, go to the Symptom Table.</li> </ul> <ol style="list-style-type: none"> <li>Go to Test E: Motronic Control Unit Test, if the Fuel Rate Gauge does not operate.</li> <li>Check/repair the WT wire, if the Fuel Rate Gauge operates.</li> </ol>		

(Test C continued on next page)

## 2460-6 ELECTRONIC TRANSMISSION CONTROL

(Test C continued from previous page)

2. Go to Test E: Motronic Control Unit Test, if the Tachometer does not operate.
  - Check/repair the BK/BU wire if the Tachometer operates.

### D: HYDRAULIC PRESSURE REGULATOR AND SOLENOID TEST

Measure: RESISTANCE At: TRANSMISSION CONTROL UNIT CONNECTOR (Disconnected)		
Measure Between	Correct Resistance	For Diagnosis
1 (VI) & Ground	Greater than 500 K Ohms	See 1
1 (VI) & 25 (BU)	25 to 46 Ohms	See 2
1 (VI) & 20 (GY)	25 to 46 Ohms	See 2
1 (VI) & 17 (GN)	25 to 46 Ohms	See 2
1 (VI) & 16 (OR)	25 to 46 Ohms	See 2
1 (VI) & 22 (RD)	1.8 to 4.6 Ohms	See 3

- If all the results are correct, replace the Transmission Control Unit.

1. Check the wiring from terminals 1, 16, 17, 20, 22, and 25 for shorts to ground (see schematic). Check the Pressure Regulator and Solenoids for a short to ground if wiring is OK. Repair/replace as necessary.
2. Check/repair wire (see schematic) and connector terminal. Replace the Solenoid Valve (see schematic), if wire and connector terminal are OK.

3. Check/repair wire (see schematic) and connector terminal. Replace the Hydraulic Pressure Regulator Solenoid, if wire and connector terminal are OK.

### E: MOTRONIC CONTROL UNIT TEST

Measure: VOLTAGE At: MOTRONIC CONTROL UNIT CONNECTOR (Connected) Condition: • Ignition Switch: RUN		
Measure Between	Correct Voltage	For Diagnosis
10 (BR/GN) & Ground	Approximately 5 Volts	See 1
11 (WT) & Ground	Greater than 10 Volts	See 1
21 (BK/BU) & Ground	Greater than 10 Volts	See 1
3 (BR/BK) & Ground	Approximately 5 Volts	See 1

- If all the results are correct, check/repair the wire(s) to the Transmission Control Unit for an open(s).

1. Check the wire to the Transmission Control Unit for a short to ground (see schematic). Check/replace the Motronic Control Unit if wire is OK.

### F: PROGRAM SELECTOR SWITCH RETURN TEST

Measure: VOLTAGE At: PROGRAM SELECTOR SWITCH CONNECTOR C1 (Connected) Condition: • Ignition Switch: START		
Measure Between	Correct Voltage	For Diagnosis
1 (BK) & Ground	Greater than 8 Volts	See 1
1 (BK) & 2 (BR)	Greater than 8 Volts	See 2

- If all the results are correct, replace the Program Selector Switch.

1. Check/repair the BK wire for an open (see schematic).
2. Check/repair the BR wire for an open (see schematic).

### G: TRANSMISSION FAULT INDICATOR TEST (TABLE 1)

Measure: VOLTAGE At: TRANSMISSION CONTROL UNIT CONNECTOR (Connected) Condition: • Ignition Switch: RUN		
Measure Between	Correct Voltage	For Diagnosis
33 (RD/WT) & Ground	Greater than 10 Volts	See 1

- If the voltage is correct, go to Table 2.

1. Replace the Transmission Control Unit.

(Continued on next page)

(Continued from previous page)

**G: TRANSMISSION FAULT INDICATOR TEST (TABLE 2)**

Measure: VOLTAGE At: TRANSMISSION RANGE DISPLAY CONNECTOR (Disconnected) Condition: • Ignition Switch: RUN		
Measure Between	Correct Voltage	For Diagnosis
1 (RD/WT) & Ground	Greater than 10 Volts	See 1
1 (RD/WT) & 2 (BR)	Greater than 10 Volts	See 2
<ul style="list-style-type: none"> <li>If all the voltages are correct, check the bulb and printed circuit board. Replace as necessary.</li> </ul> <ol style="list-style-type: none"> <li>Check/repair the RD/WT wire for an open (see schematic).</li> <li>Check/repair the BR wire for an open (see schematic).</li> </ol>		

**H: 321 INDICATOR TEST**

Measure: VOLTAGE At: TRANSMISSION RANGE DISPLAY CONNECTOR (Disconnected) Conditions: • Ignition Switch: RUN • Program Selector Switch: 321		
Measure Between	Correct Voltage	For Diagnosis
3 (BR/WT) & Ground	0 Volts	See 1
12 (GN/BK) & Ground	Greater than 10 Volts	See 2
<ul style="list-style-type: none"> <li>If all the results are correct, check the GY wire bulb, printed circuit board, and connector terminals. Repair/replace as necessary.</li> </ul> <ol style="list-style-type: none"> <li>Check/repair the BR/WT wire and the connector terminal (see schematic).</li> <li>Check/repair the GN/BK wire for an open (see schematic).</li> </ol>		

**I: PROGRAM SELECTOR SWITCH CONTINUITY TEST**

Measure: RESISTANCE At: TRANSMISSION CONTROL UNIT CONNECTOR (Disconnected) Conditions: • Transmission Range Display Connector: DISCONNECTED • Program Selector Switch: E		
Measure Between	Correct Resistance	For Diagnosis
14 (BR/RD) & 6 (BR)	Approximately 0 Ohms	See 1
<ul style="list-style-type: none"> <li>Set Program Selector Switch to 321.</li> </ul>		
15 (BR/WT) & 6 (BR)	Approximately 0 Ohms	See 1
<ul style="list-style-type: none"> <li>Set Program Selector Switch to S.</li> </ul>		
14 (BR/RD) & 6 (BR)	Infinite Ohms	See 2
15 (BR/WT) & 6 (BR)	Infinite Ohms	See 2
<ul style="list-style-type: none"> <li>If all the results are correct, replace the Transmission Control Unit.</li> </ul> <ol style="list-style-type: none"> <li>Check the wires and connector terminal (see schematic). Replace the Program Selector Switch if wires are OK.</li> <li>Replace the Program Selector Switch.</li> </ol>		

## 2460-8 ELECTRONIC TRANSMISSION CONTROL

### J: TRANSMISSION SPEED SENSOR TEST (TABLE 1)

Measure: RESISTANCE At: TRANSMISSION CONTROL UNIT CONNECTOR (Disconnected)		
Measure Between	Correct Resistance	For Diagnosis
8 (BR) & Ground	Greater than 500 K Ohms	See 1
8 (BR) & 27 (WT)	800 Ohms to 1.6 K Ohms	See 2
<ul style="list-style-type: none"> <li>If all the results are correct, go to Table 2.</li> </ul> <ol style="list-style-type: none"> <li>Check/repair the wires from terminals 8 and 27 for shorts to ground (see schematic). Replace the Transmission Output Speed Sensor if wires are OK.</li> <li>Check/repair the wires from terminals 8 and 27 for opens (see schematic). Replace the Transmission Output Speed Sensor if wires are OK.</li> </ol>		

### J: TRANSMISSION SPEED SENSOR TEST (TABLE 2)

Measure: AC VOLTAGE At: TRANSMISSION CONTROL UNIT CONNECTOR (Disconnected)		
Conditions:		
<ul style="list-style-type: none"> <li>Lift car (rear wheels must turn freely)</li> <li>Engine running</li> <li>Gear Selector: D</li> <li>Speedometer: 30 km/h (20 mph)</li> </ul>		
Measure Between	Correct Voltage	For Diagnosis
8 (BR) & 27 (WT)	Greater than 3.5 Volts AC	See 1
<ul style="list-style-type: none"> <li>If the result is correct, replace the Transmission Control Unit.</li> </ul> <ol style="list-style-type: none"> <li>Replace the Transmission Output Speed Sensor.</li> </ol>		

### K: KICKDOWN SWITCH TEST

Measure: VOLTAGE At: TRANSMISSION CONTROL UNIT CONNECTOR (Connected)		
Condition:		
<ul style="list-style-type: none"> <li>Ignition Switch: RUN</li> </ul>		
Measure Between	Correct Voltage	For Diagnosis
2 (GY/YL) & Ground	Approximately 5 Volts	See 1
<ul style="list-style-type: none"> <li>Depress accelerator pedal to Kickdown.</li> </ul>		
2 (GY/YL) & Ground	0 Volts	See 2
<ul style="list-style-type: none"> <li>If all the results are correct, check the BMW Troubleshooting Manual to verify the problem is not in the Transmission. Replace the Transmission Control Unit, if the problem is not in the Transmission.</li> </ul> <ol style="list-style-type: none"> <li>Check the GY/YL wire and Kickdown Switch for a short to ground (see schematic). Replace the Transmission Control Unit if GY/YL wire and Kickdown Switch are OK.</li> <li>Check the GY/YL wire for an open (see schematic). Replace the Kickdown Switch if GY/YL wire is OK.</li> </ol>		

### L: GEAR INPUT TEST

Measure: VOLTAGE At: TRANSMISSION CONTROL UNIT CONNECTOR (Connected)		
Conditions:		
<ul style="list-style-type: none"> <li>Ignition Switch: RUN</li> <li>Gear Selector: N (Neutral)</li> </ul>		
Measure Between	Correct Voltage	For Diagnosis
4 (BU/BR) & Ground	Battery	See 1
<ul style="list-style-type: none"> <li>Put the Gear Selector in all positions except N (Neutral).</li> </ul>		
4 (BU/BR) & Ground	Less than 1 Volt	See 2
<ul style="list-style-type: none"> <li>Put the Gear Selector in D (Drive).</li> </ul>		
30 (BU/GN) & Ground	Battery	See 1
<ul style="list-style-type: none"> <li>Put the Gear Selector in all positions except D (Drive).</li> </ul>		
30 (BU/GN) & Ground	Less than 1 Volt	See 2
<ul style="list-style-type: none"> <li>Put the Gear Selector in 3 (third gear).</li> </ul>		
29 (BU/GY) & Ground	Battery	See 1
<ul style="list-style-type: none"> <li>Put the Gear Selector in all positions except 3 (third gear).</li> </ul>		
29 (BU/GY) & Ground	Less than 1 Volt	See 2
<ul style="list-style-type: none"> <li>Put the Gear Selector in 2 (second gear).</li> </ul>		
28 (BU/BK) & Ground	Battery	See 1
<ul style="list-style-type: none"> <li>Put the Gear Selector in all positions except 2 (second gear).</li> </ul>		

(L: Gear Input Test continued on next page)

(L: Gear Input Test continued from previous page)

28 (BU/GY) & Ground	Less than 1 Volt	See 2
<ul style="list-style-type: none"> <li>Put the Gear Selector in 1 (first gear).</li> </ul>		
18 (BU/RD) & Ground	Battery	See 1
<ul style="list-style-type: none"> <li>Put the Gear Selector in all positions except 1 (first gear).</li> </ul>		
18 (BU/RD) & Ground	Less than 1 Volt	See 2
<ul style="list-style-type: none"> <li>If all the results are correct, go to the Symptom Table.</li> </ul> <ol style="list-style-type: none"> <li>If the associated bulb in the Transmission Range Display lights, check/repair the wire to the Transmission Range Display for an open (see schematic).</li> <li>If the associated bulb in the Transmission Range Display does not light, check/repair wire from the Automatic Transmission Range Switch, and the Automatic Transmission Range Switch (see schematic).</li> <li>Check/repair the wire for a short to voltage and the Automatic Transmission Range Switch (see schematic).</li> </ol>		

**M: THROTTLE POSITION SENSOR AND WIDE OPEN THROTTLE OUTPUT TEST**

<b>Measure: VOLTAGE</b> <b>At: TRANSMISSION CONTROL UNIT CONNECTOR (Connected)</b> <b>Condition:</b> <ul style="list-style-type: none"> <li>Ignition Switch: RUN</li> </ul>		
Measure Between	Correct Voltage	For Diagnosis
31 (BR/BK) & Ground	Approximately 5 Volts	See 1
9 (OR/BK) & Ground	Approximately 5 Volts	See 2
9 (OR/BK) & 6 (BR)	Approximately 5 Volts	See 2
<ul style="list-style-type: none"> <li>Operate Throttle through its full range.</li> </ul>		
7 (YL) & 6 (BR)	.7 Volts (Throttle closed) increasing evenly to 4.77 Volts (Throttle fully opened)	See 3
<ul style="list-style-type: none"> <li>Depress throttle pedal to the floor.</li> </ul>		
31 (BR/BK) & Ground	Approximately .3 Volts	See 2
<ul style="list-style-type: none"> <li>If all the results are correct, go to the Symptom Table.</li> </ul> <ol style="list-style-type: none"> <li>Go to Test E: Motronic Control Unit Test.</li> <li>Replace the Transmission Control Unit.</li> <li>Check/repair the wiring to the Throttle Position Sensor. Adjust the Throttle Position Sensor if wiring is OK. Replace the Throttle Position Sensor if adjustment does not correct the problem.</li> </ol>		

**NOTE:** The highest voltage at full open position should be .22 volts less than the stabilized voltage. Adjust Throttle Position Sensor accordingly.

**CIRCUIT OPERATION**

By operating the Program Selector Switch, the driver can select 3 different transmission modes. When the Program Selector Switch is set to E (Economy), the Economy Input (terminal 14) in the Transmission Control Unit is grounded through terminal 6. The Economy Mode is designed for smooth, refined shift points and low fuel consumption. A fourth gear, or overdrive ratio, is available in the Economy Mode to reduce engine speed and noise level. When the Program Selector Switch is set to 321, the 321 Input (terminal 15), in the Transmission Control Unit, is grounded through terminal 6 and the 321 Indicator lights. The Transmission does not shift up or down and will operate in the selected gear only. When the Program Selector Switch is set to S, voltage is present at the Economy and 321 Inputs in the Transmission Control Unit. Fourth gear is not selected and first, second and third gears are kept selected up to full engine speed. The Program Selector Switch is designed to return to E when the engine is cranked. When the engine is cranked, voltage is applied to the coil in the Program Selector Switch through the Ignition Switch and the Start Relay. The coil energizes and the Program Selector returns to E.

The Transmission Control Unit monitors engine speed (terminal 21), fuel rate (terminal 11), Throttle position (terminal 7), road speed (terminals 8 and 27), Kickdown signal (terminal 2), Gear Selector position (terminals 4, 30, 29, 28 and 18) and Program Selector Switch position (terminals 14 and 15). The Transmission Control Unit's electronic processing circuit compares this information with the program data to establish the correct gear and smooth shift points, by controlling the Shift Valve Solenoids and the Hydraulic Pressure Regulator.

The Transmission Fault Indicator will light with the engine running, if a problem with the control system occurs. When a fault is detected, the vehicle can only be driven in third and reverse gears. Neutral and Park also retain their functions. Voltage to the transmission (terminal 1) is not present when a fault is detected.

The Reverse Gear Inhibit Lock Solenoid prevents the driver from selecting reverse above 5 mph.

# 3234-0 SUPPLEMENTAL RESTRAINT SYSTEM (SRS)

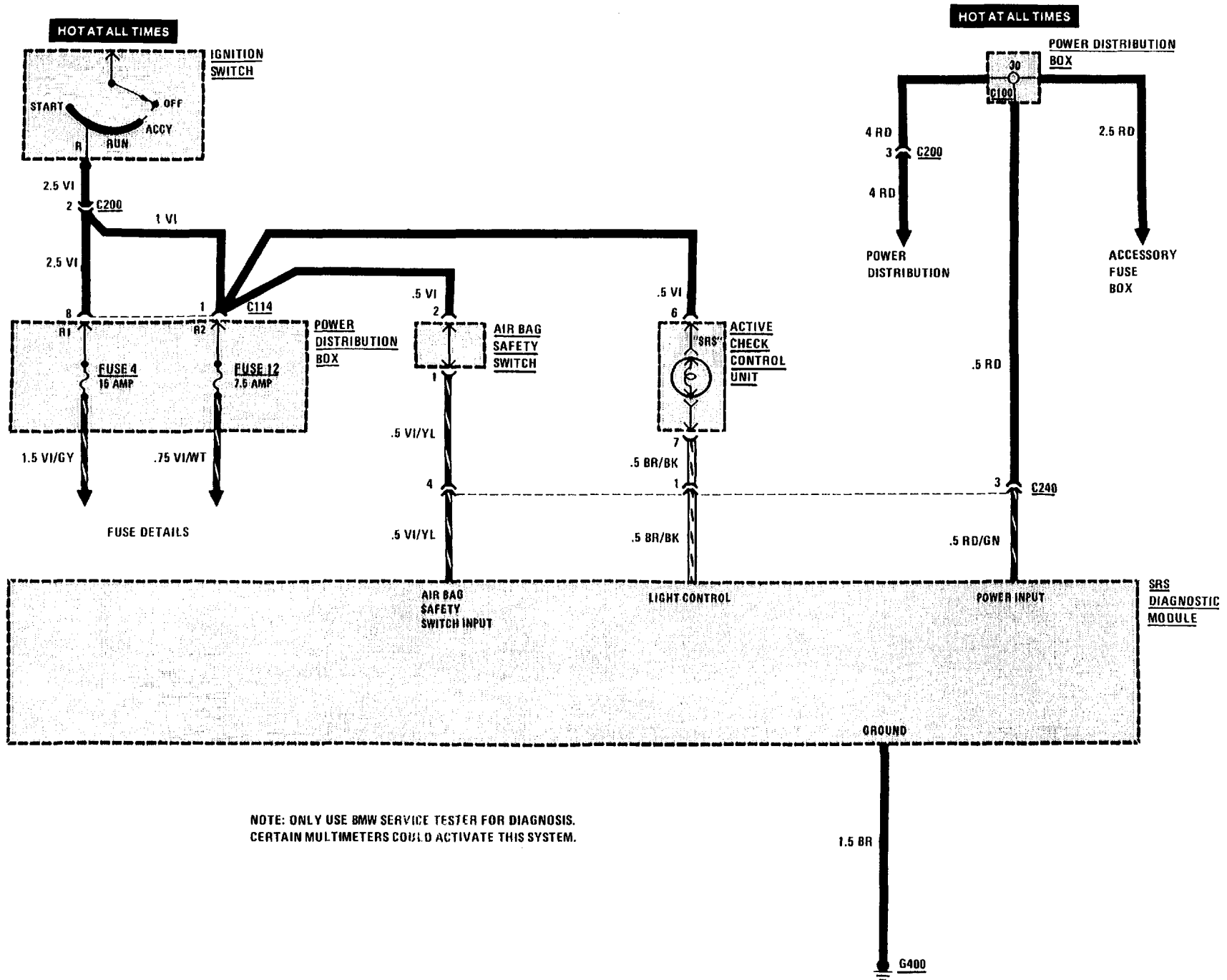

NOTE: ONLY USE BMW SERVICE TESTER FOR DIAGNOSIS.  
CERTAIN MULTIMETERS COULD ACTIVATE THIS SYSTEM.



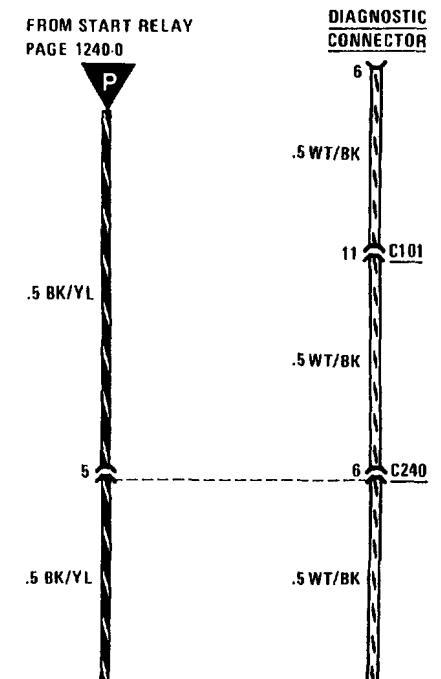

\*Connector C260 and the air bag gas generator connector are fitted with a shorting bridge, which is used to prevent unintentional triggering of the igniter when working on the air bag system. Only Special Tool 62 1 260 (testing lead) may be used to check the wire loop and igniter resistance. When connecting on the yellow, 2 pin plug, the shorting bridge will release both plug lugs and it is only then possible to measure the resistance of wires, wire loop and the igniter.

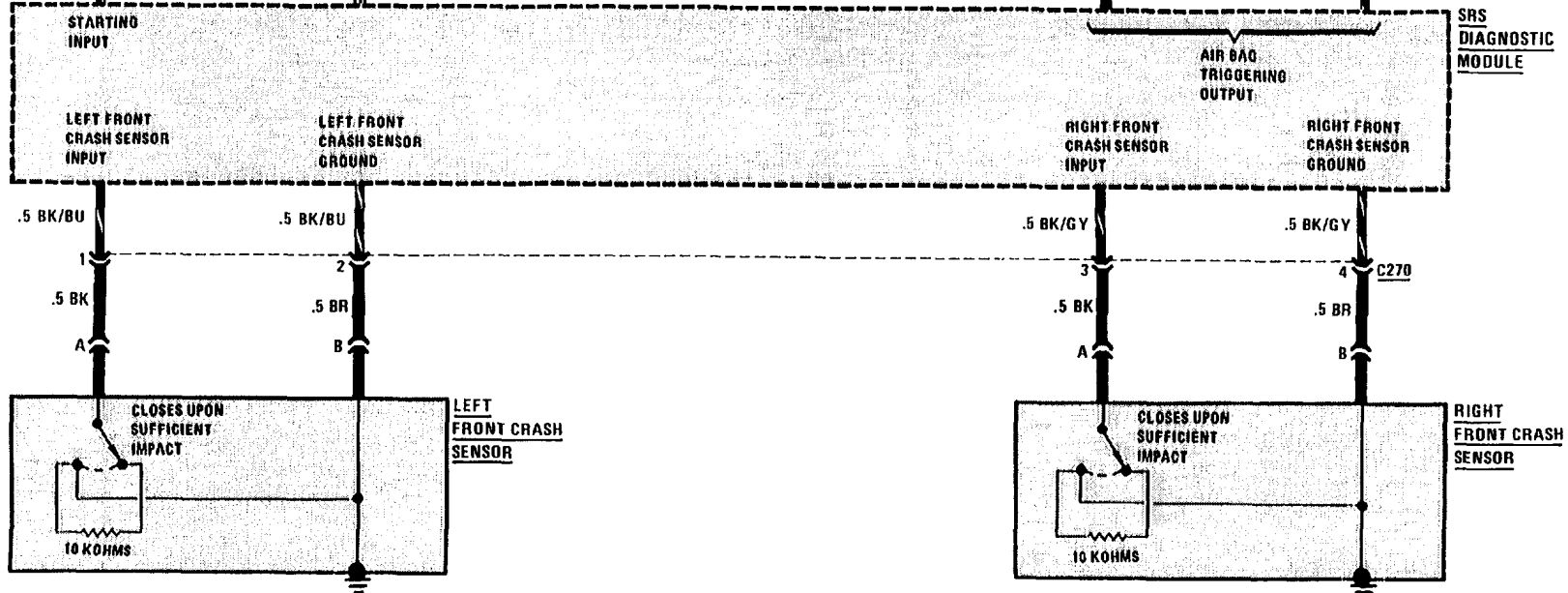
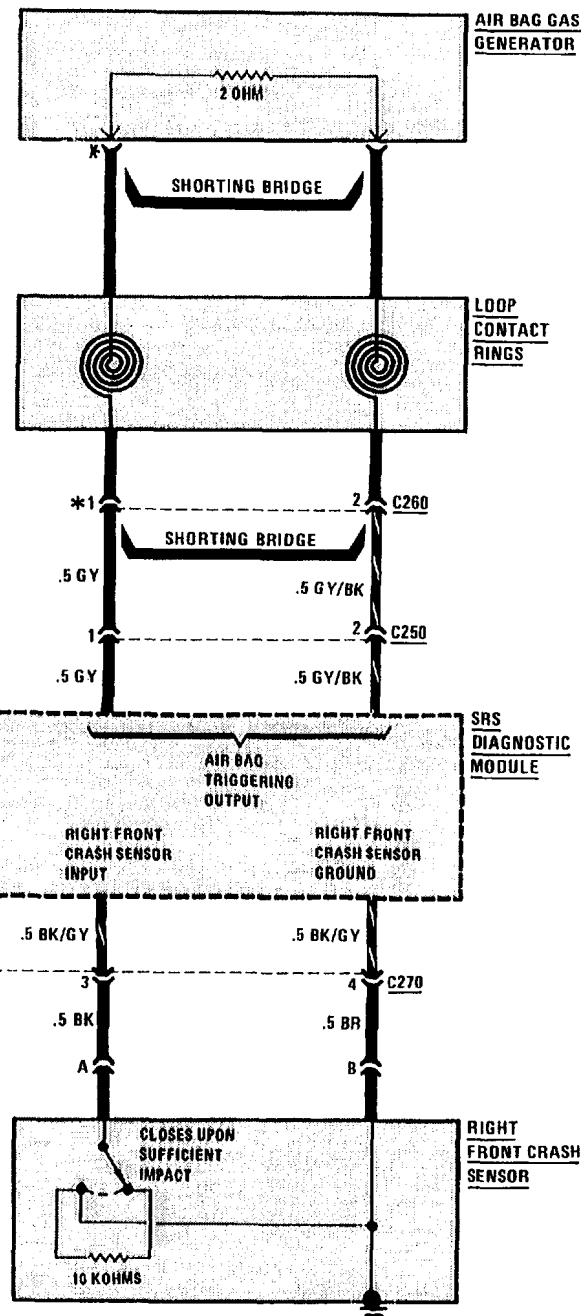

# 3435-0 BRAKE LINING WARNING

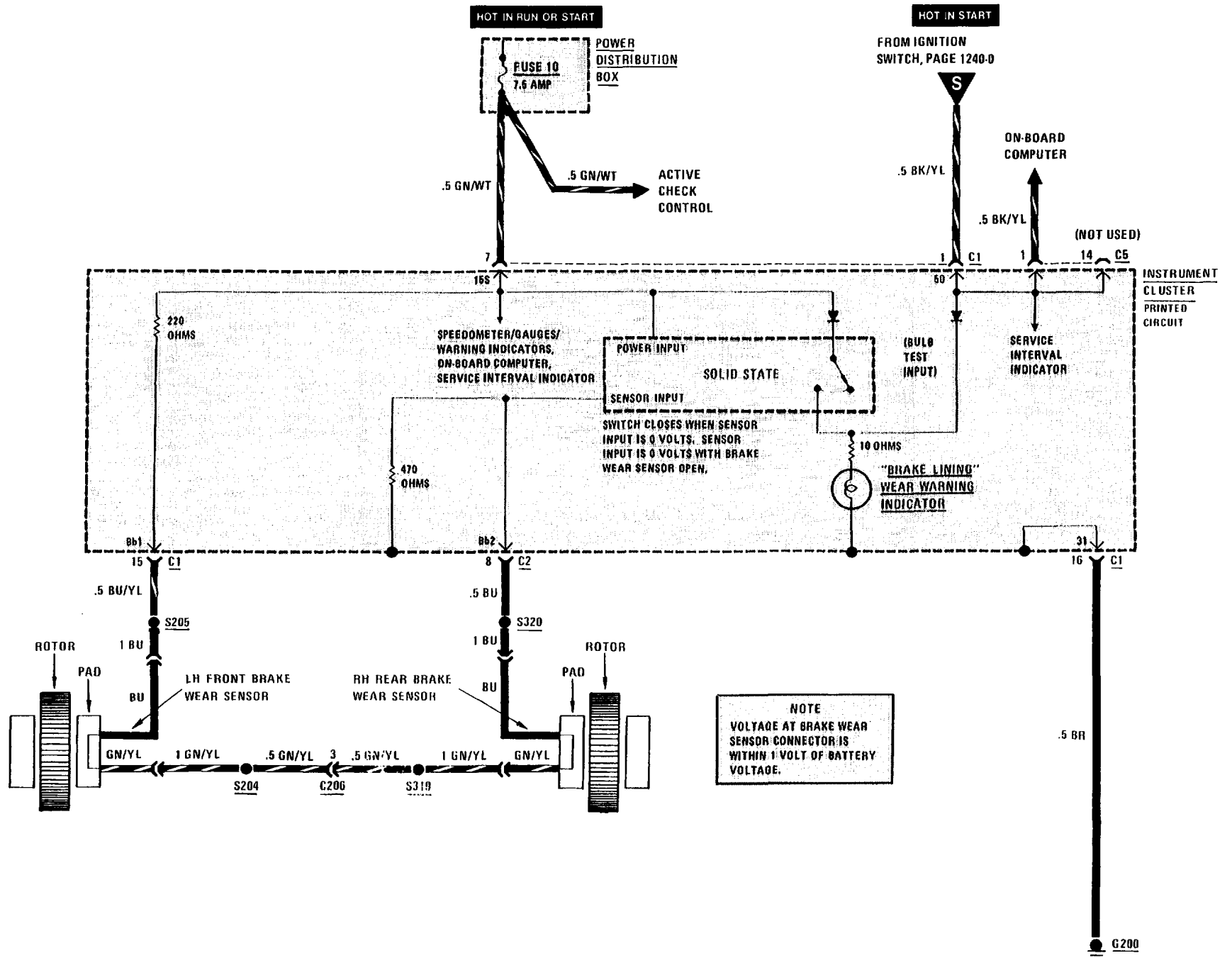



# ANTILOCK BRAKING SYSTEM (ABS) 3450-1

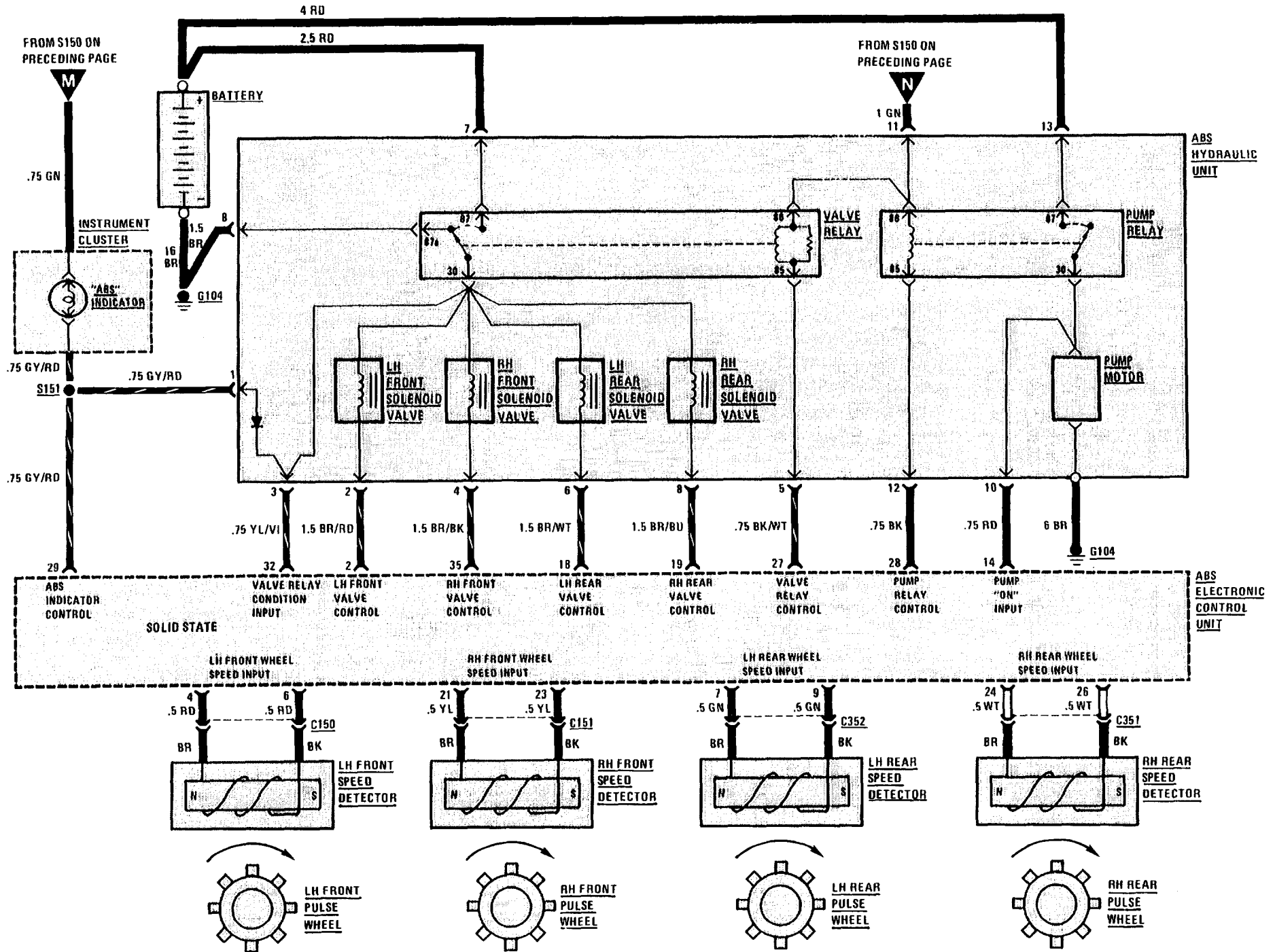

# 5116-0 POWER MIRRORS

**HOT IN RUN ONLY FROM UNLOADER RELAY K5**

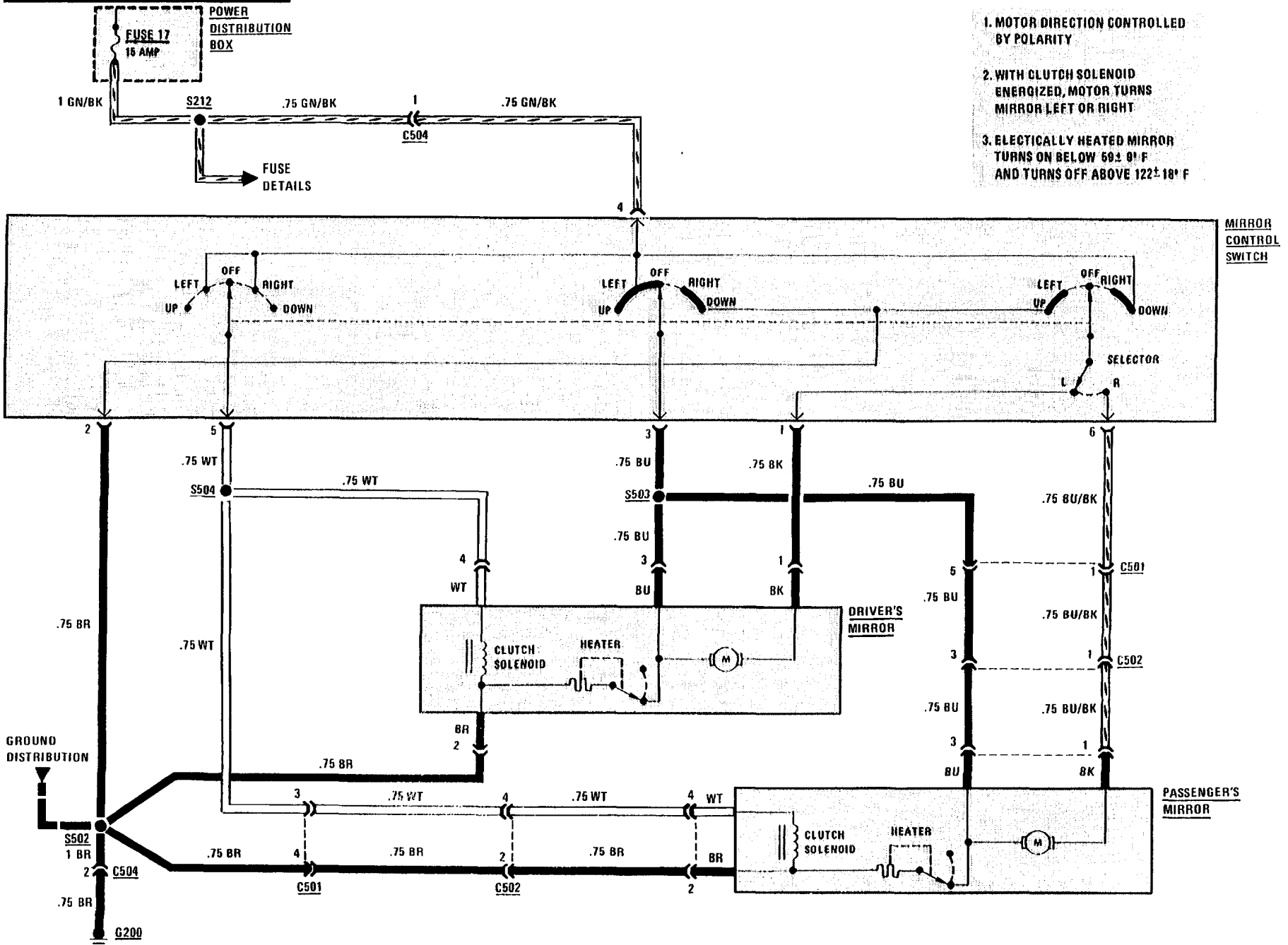

# 5126-0 CENTRAL LOCKING

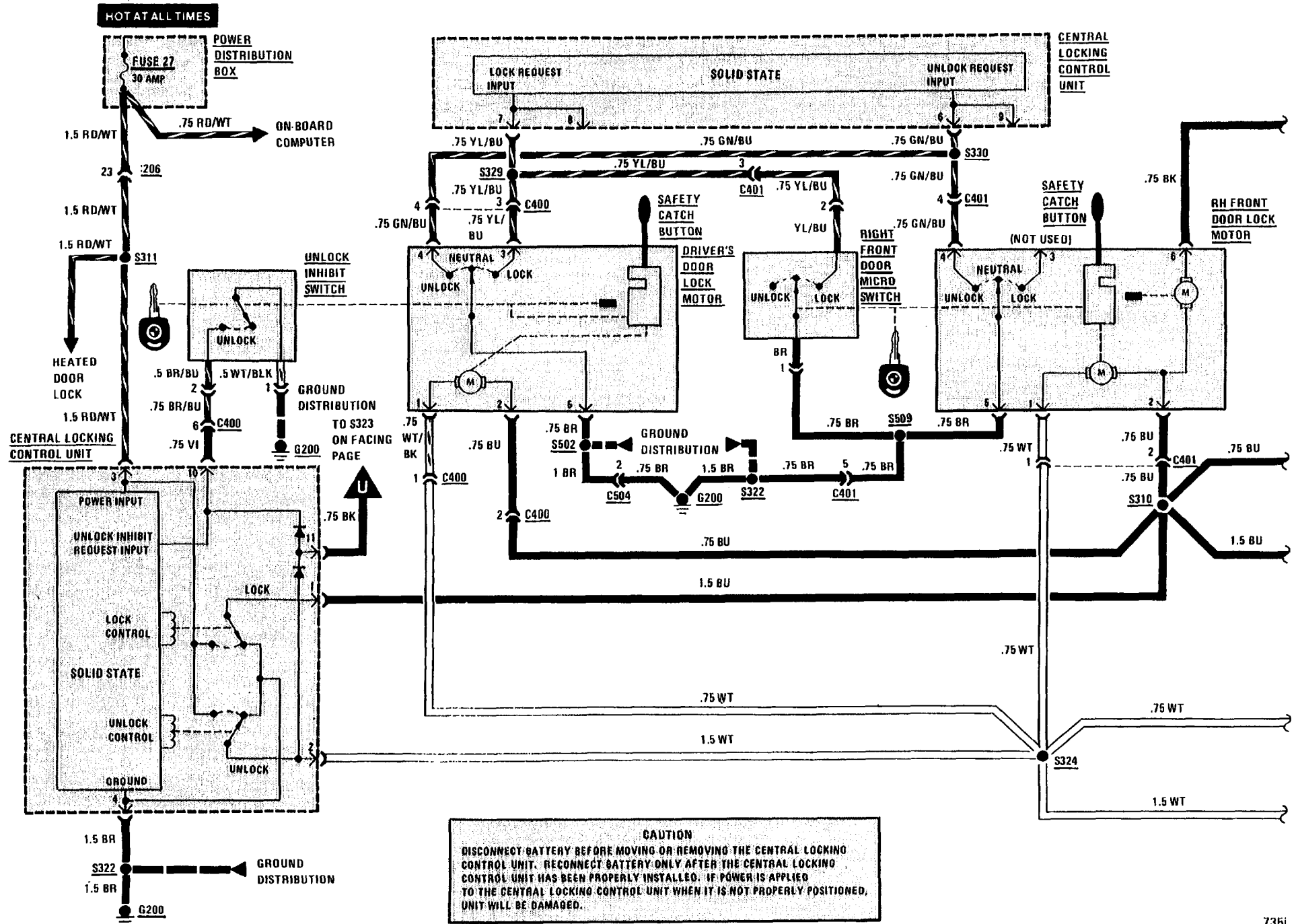

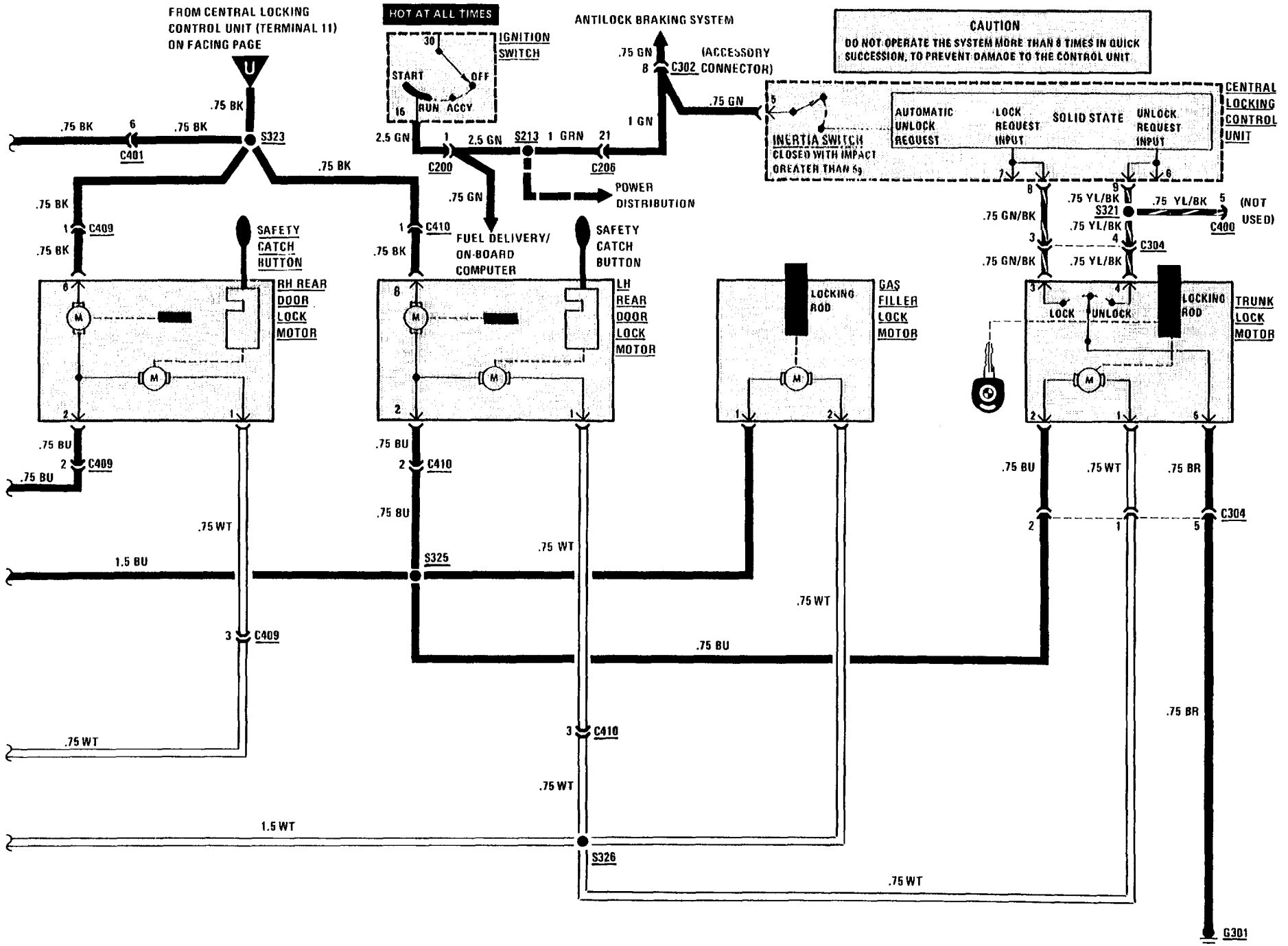

## 5126-2 CENTRAL LOCKING

### TROUBLESHOOTING HINTS

1. Check Fuse 27 by operating the On-Board Computer.

### SYSTEM CHECK

- Operate controls in sequence listed in the System Check Table.
- Refer to Repair Action for the Response received (Tests follow the System Check Table).
- After any repair, repeat System Check to verify proper system operation.

**NOTE:** Before replacing any system component, check all connectors, splices, and wiring to that component.

### COMPONENT LOCATION

		Page-Figure
Auto. Trans. Range Switch . . .	Below console, on base of shift lever . . . . .	7000- 9-5
Kickdown Switch . . . . .	Below accelerator pedal	
Main Relay . . . . .	Behind right front shock tower . . . . .	7000- 7-1
Motronic Control Unit . . . . .	Behind right front speaker. . . . .	7000- 9-6
Power Distribution Box . . . . .	Top front of left front wheel well . . . . .	7000- 4-5
Throttle Position Sensor . . . . .	Top of engine	
Transmission Control Unit . . . . .	Behind left front speaker . . . . .	7000- 9-4
C152 (8 pin) . . . . .	Near transmission	
C207 (2 pin) . . . . .	Under LH side of dash near body electrical bracket . .	7000- 8-4
C238 (13 pin) . . . . .	Behind right front speaker. . . . .	7000- 9-6
C301 (2 pin) . . . . .	In center console, ahead of shift lever. . . . .	7000- 9-5
G104 (Main Body Ground) . . . . .	On power distribution box bracket . . . . .	7000- 4-5

### SYSTEM CHECK TABLE

OPERATION	RESPONSE	REPAIR ACTION
1. Insert the key in the Driver's door and turn to LOCK	All doors lock	None, proceed to Operation 2
	Some doors lock	Repair/replace the suspect Door Lock Motor circuit
	No doors lock	Proceed to Operation 4
2. Turn the key to UNLOCK INHIBIT (clockwise until key is horizontal)	All doors double lock (Safety Catch Buttons cannot be pulled up by hand)	None, proceed to Operation 3
	Driver's door double locks and only some of the other doors double lock	Repair/replace the suspect Door Lock Motor
	Driver's door double locks but all the other doors do not double lock	Perform Test B
	Driver's door does not double lock	Mechanical problem, see BMW Troubleshooting Manual



**SYSTEM CHECK TABLE (CONT'D)**

OPERATION	CORRECT RESPONSE	REPAIR ACTION
3. Turn the key to UNLOCK	All doors unlock	None, proceed to Operation 4
	Some doors unlock	Repair/replace the suspect Door Lock Motor circuit
	No doors unlock	Proceed to Operation 5
4. Insert the key in the Passenger's door and turn to LOCK	All doors lock	If the doors did not lock in Operation 1, repair/replace the Driver's Door Lock Switch, otherwise proceed to Operation 5
	Some doors lock	Repair/replace the suspect Door Lock Motor circuit
	No doors lock	If all the doors locked in Operation 1, repair/replace the Right Front Door Microswitch. If the doors did not lock in Operation 1, perform Test A
5. Insert the key in the Passenger's door and turn to UNLOCK	All doors unlock	If all the doors did not unlock in Operation 3, repair/replace the Driver's Door Lock Switch, otherwise proceed to Operation 6
	Some doors unlock	Repair/replace the suspect Door Lock Motor
	No doors unlock	If all the doors unlocked in Operation 3, repair/replace the Passenger's Door Lock Switch. If the doors did not unlock in Operation 3, perform Test C
6. Get in the car and close and lock all doors Turn the Ignition Switch to RUN	Doors remain locked	None, proceed to Operation 7
	Doors unlock	Repair/replace the Central Locking Control Unit
7. Get out of the car Insert the key in the Driver's door and turn to LOCK Unlock each of the doors by pulling up the Safety Catch Buttons	All doors can be unlocked	None, proceed to Operation 8
	All doors remain secure	Disconnect the connector from the Central Locking Control Unit and check for a short to ground in the BK wires at terminal 11. • If short to ground is not present, replace the Central Locking Control Unit. • If short to ground is present isolate wiring from Door Lock Motors one at a time to find short

SYSTEM CHECK TABLE (CONT'D)

OPERATION	CORRECT RESPONSE	REPAIR ACTION
8. Insert the key in the Trunk Cylinder Switch. Turn the key to LOCK	Trunk locks	None, proceed to Operation 9
	Trunk does not lock	If the doors lock, repair/replace the Trunk Lock Motor Circuit or Trunk Lock Motor If the doors do not lock, repair/replace the Trunk Switch Repair/replace the Central Locking Control Unit if the Trunk Switch Circuit is OK
9. Turn the key to UNLOCK	Trunk unlocks	None, proceed to Operation 10
	Trunk does not unlock	If the doors unlock, repair/replace the Trunk Lock Motor circuit or Trunk Lock Motor If the doors do not unlock, repair/replace the Trunk Switch Repair/replace the Central Locking Control Unit if the Trunk Switch Circuit is OK
10. Turn the key back to LOCK	Gas Filler locks	None, proceed to Operation 11
	Gas Filler does not lock	Repair/replace the Gas Filler Lock Motor circuit
11. Turn the key to UNLOCK	Gas Filler unlocks	None
	Gas Filler does not unlock	Repair/replace the Gas Filler Lock Motor circuit

- If all results are normal, the system is OK.

SYSTEM DIAGNOSIS

- Do the following tests when directed by the System Check Table.

A: CONTROL UNIT LOCK TEST (TABLE 1)

Measure: VOLTAGE At: CONTROL UNIT CONNECTOR (Connected)		
Measure Between	Correct Voltage	For Diagnosis
3 (RD/WT) & Ground	Battery	See 1
3 (RD/WT) & 4 (BR)	Battery	See 2
<ul style="list-style-type: none"> <li>• If the voltages are correct, proceed to Table 2.</li> <li>1. Check the RD/WT wire for an open.</li> <li>2. Check the BR wire for an open to ground (see schematic).</li> </ul>		

A: CONTROL UNIT LOCK TEST (TABLE 2)

Connect: A FUSED JUMPER At: CONTROL UNIT CONNECTOR (Connected)		
Jumper Between	Correct Result	For Diagnosis
7 (YL/BU) & Ground	Doors lock	See 1
<ul style="list-style-type: none"> <li>• If the result is correct, repair/replace the switches and related wiring (see schematic).</li> <li>1. Proceed to Table 3.</li> </ul>		

**A: CONTROL UNIT LOCK TEST  
(TABLE 3)**

Connect: FUSED JUMPERS At: CONTROL UNIT CONNECTOR (Disconnected)		
Jumper Between	Correct Result	For Diagnosis
1 (BU) & 3 (RD/WT) 2 (WT) & 4 (BR)	Doors lock	See 1
<ul style="list-style-type: none"> <li>If the result is correct, replace the Central Locking Control Unit.</li> </ul> <ol style="list-style-type: none"> <li>Check the BU wire to splice S310 and the WT wire to splice S324 for opens (see schematic).</li> </ol>		

**B: UNLOCK INHIBIT TEST**

Connect: A FUSED JUMPER At: CONTROL UNIT CONNECTOR (Connected)		
Jumper Between	Correct Result	For Diagnosis
10 (VI) & Ground	Doors double lock	See 1
<ul style="list-style-type: none"> <li>If the result is correct, check the VI, BR/BU and WT/BK wires for opens (see schematic). Replace the Unlock Inhibit Switch if the wires and connections are OK.</li> </ul> <ol style="list-style-type: none"> <li>Check the BK/RD wires for opens (see schematic). Replace the Central Locking Control Unit, if the wires and connections are OK.</li> </ol>		

**C: CONTROL UNIT UNLOCK TEST**

Connect: A FUSED JUMPER At: CONTROL UNIT CONNECTOR (Connected)		
Jumper Between	Correct Result	For Diagnosis
6 (GN/BU) & Ground	Doors unlock	See 1
<ul style="list-style-type: none"> <li>If the result is correct, repair/replace the switches and related wiring (see schematic).</li> </ul> <ol style="list-style-type: none"> <li>Replace the Central Locking Control Unit.</li> </ol>		

**CIRCUIT DESCRIPTION**

The Central Locking System is controlled by the Central Locking Control Unit. This unit senses when a lock switch is moved by a key, and sends the appropriate signal to drive the Motors. The Central Lock Control Unit controls the Door Locks, Gas Filler Lock and Trunk Lock. The unit also has an Inertia Switch which closes on impact greater than 5g. If in RUN or START the locks are then unlocked.

**Lock**

When the Key is inserted into a lock and turned clockwise, the Lock switch moves to LOCK and grounds terminal 7 of the Central Locking Control Unit. The unit then activates the Lock Relay and applies voltage from Fuse 27 to the Lock Motor, which is grounded through the WT wire, Central Locking Control Unit and BR wire. The Lock Motor then pulls the lock down. The door locks also control the Trunk Lock and Gas Filler Lock.

**Unlock**

When the key is turned counterclockwise, terminal G of the Central Locking Control Unit is grounded through the Lock Switch. The Central Locking Control Unit then activates the Unlock Relay and applies voltage from Fuse 27, through the WT wire to the Lock Motor. The motor is grounded through the BU wire, Central Locking Control Unit, and BR wire. The polarity is reversed and the motor pushes the lock up.

**Unlock Inhibit**

When the key is inserted into the Driver's Lock and turned clockwise past the LOCK position, the Unlock inhibit mechanism is engaged. This mechanically inserts a bar into the driver's lock and prevents unlocking through use of the Safety Catch Button. When in the unlock Inhibit position, ground is applied to the Unlock Inhibit motors in the other lock units. The Central Locking Control Unit is grounded at terminal 10 and then activates the Lock Relay. Voltage is applied to the unlock inhibit motors through the BU wire. They are now activated and engage the other Unlock Inhibit mechanisms. The direction of the motors is reversed when the doors are unlocked (see Unlock).

**Trunk Lock**

The Trunk Lock operates in a manner similar to the Door Locks.

EARLY PRODUCTION

HOT IN RUN ONLY FROM UNLOADER RELAY K5

HOT AT ALL TIMES

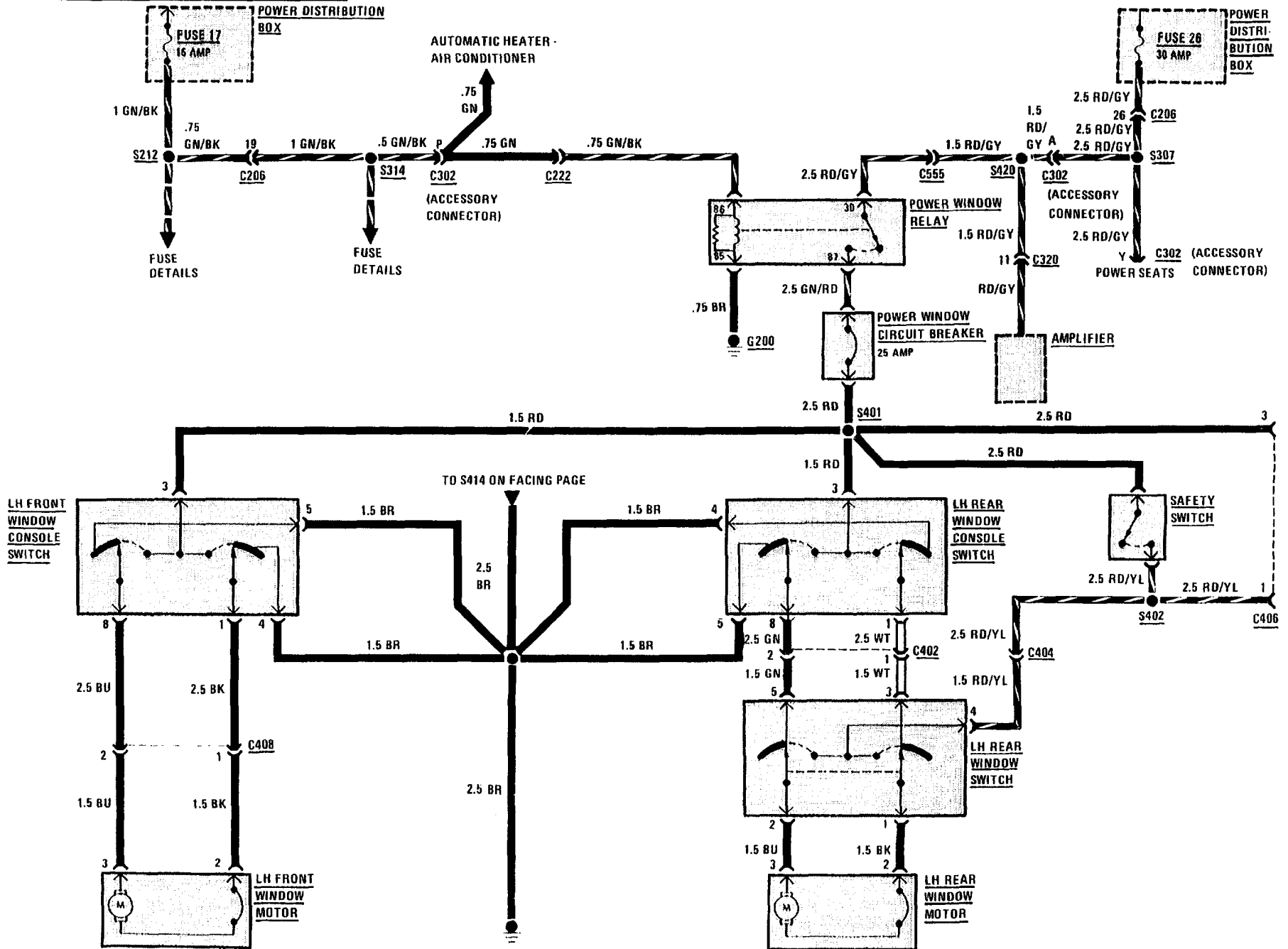

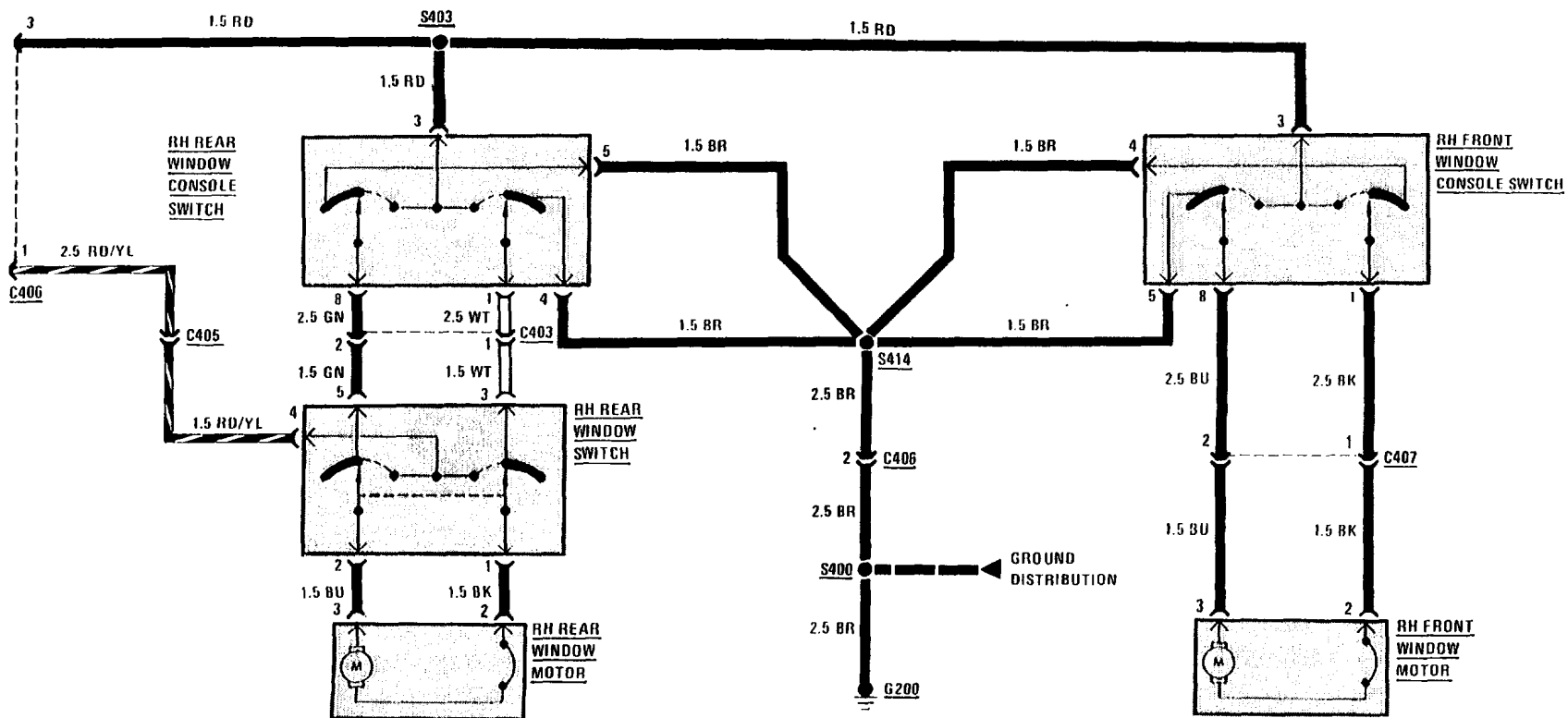

# 5133-2 POWER WINDOWS

## LATE PRODUCTION

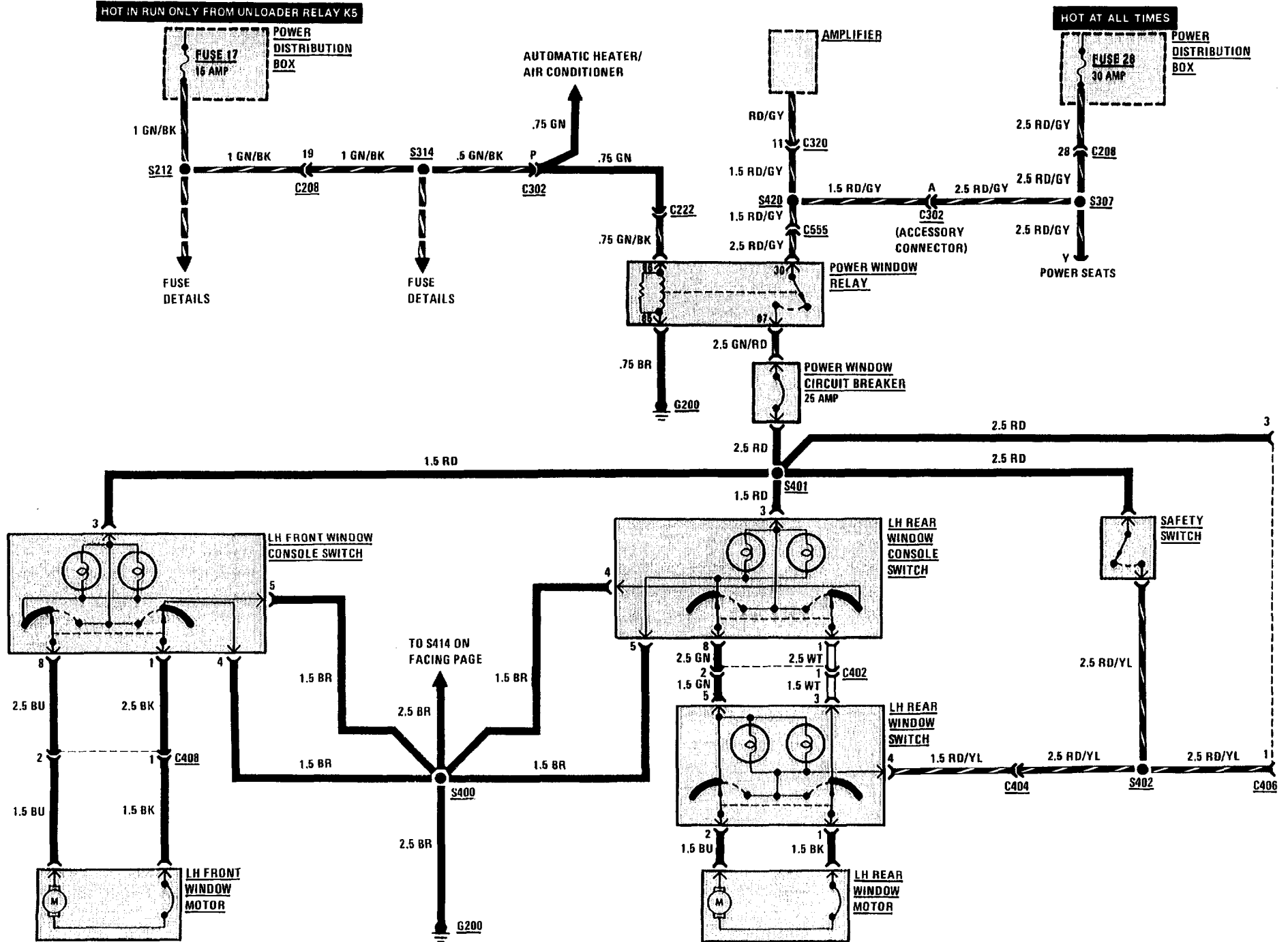

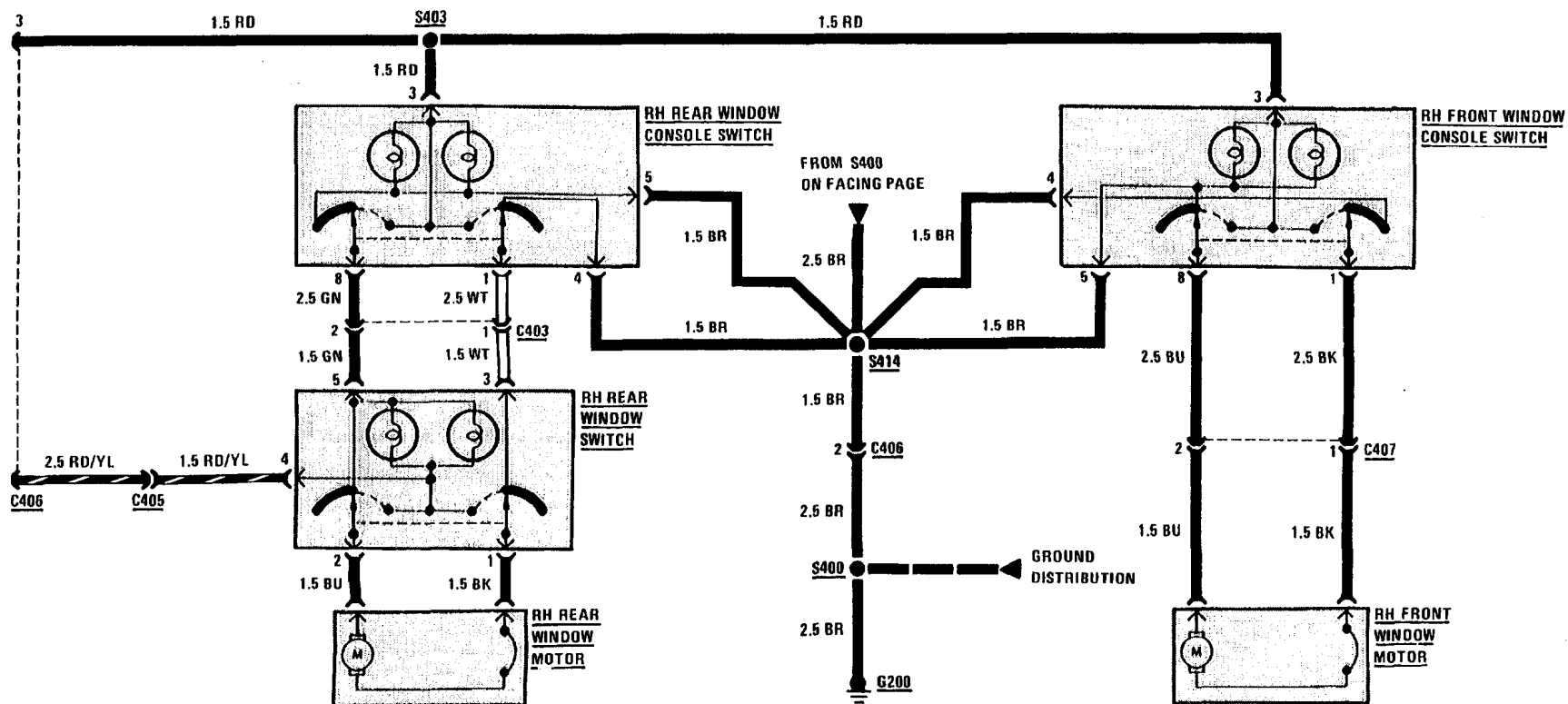

PASSENGER'S POWER SEAT

PASSENGER SEAT CONTROLLER

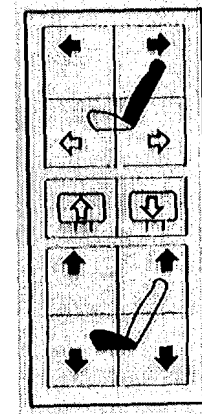
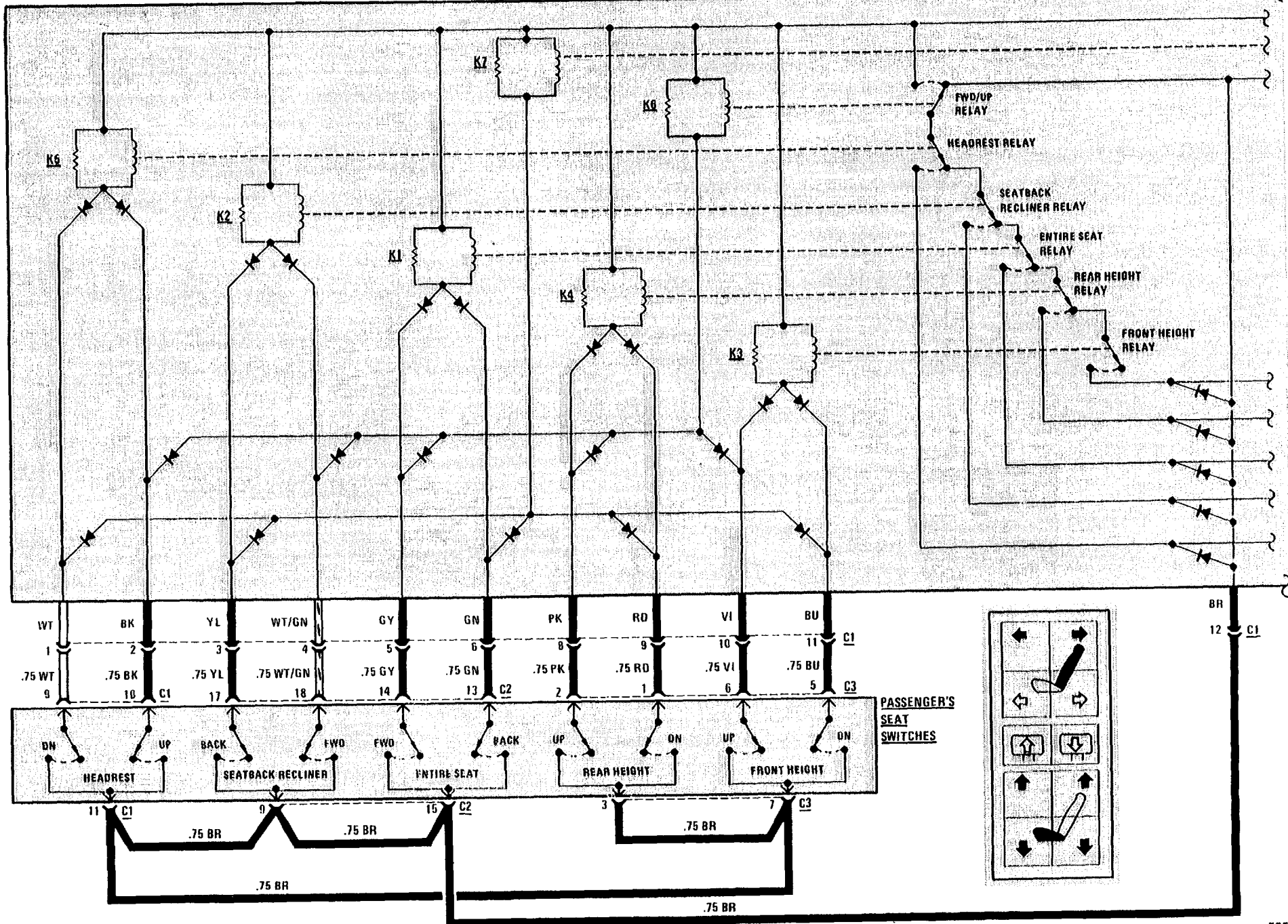



PASSENGER'S POWER SEAT

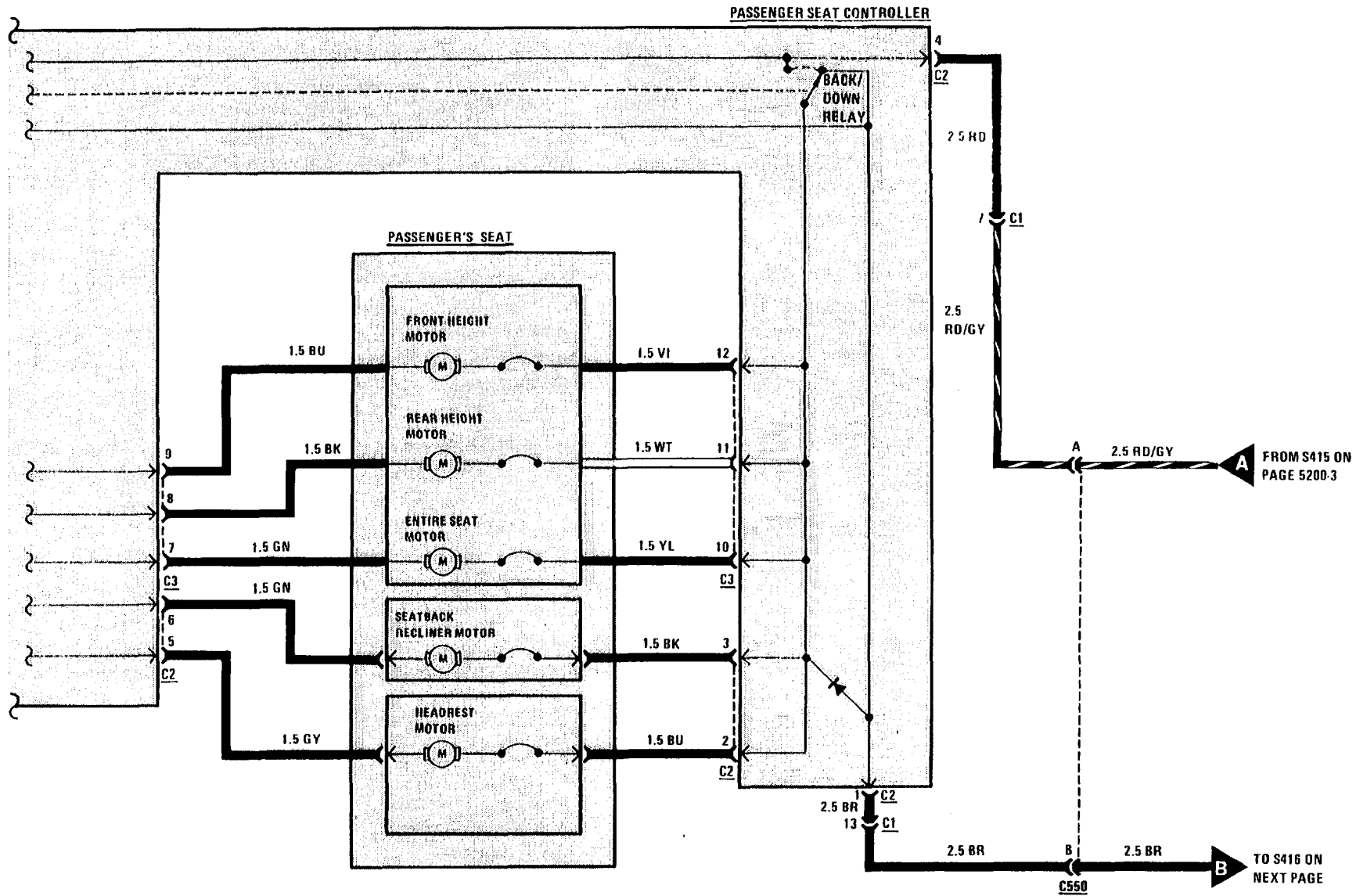

**MEMORY SEAT**

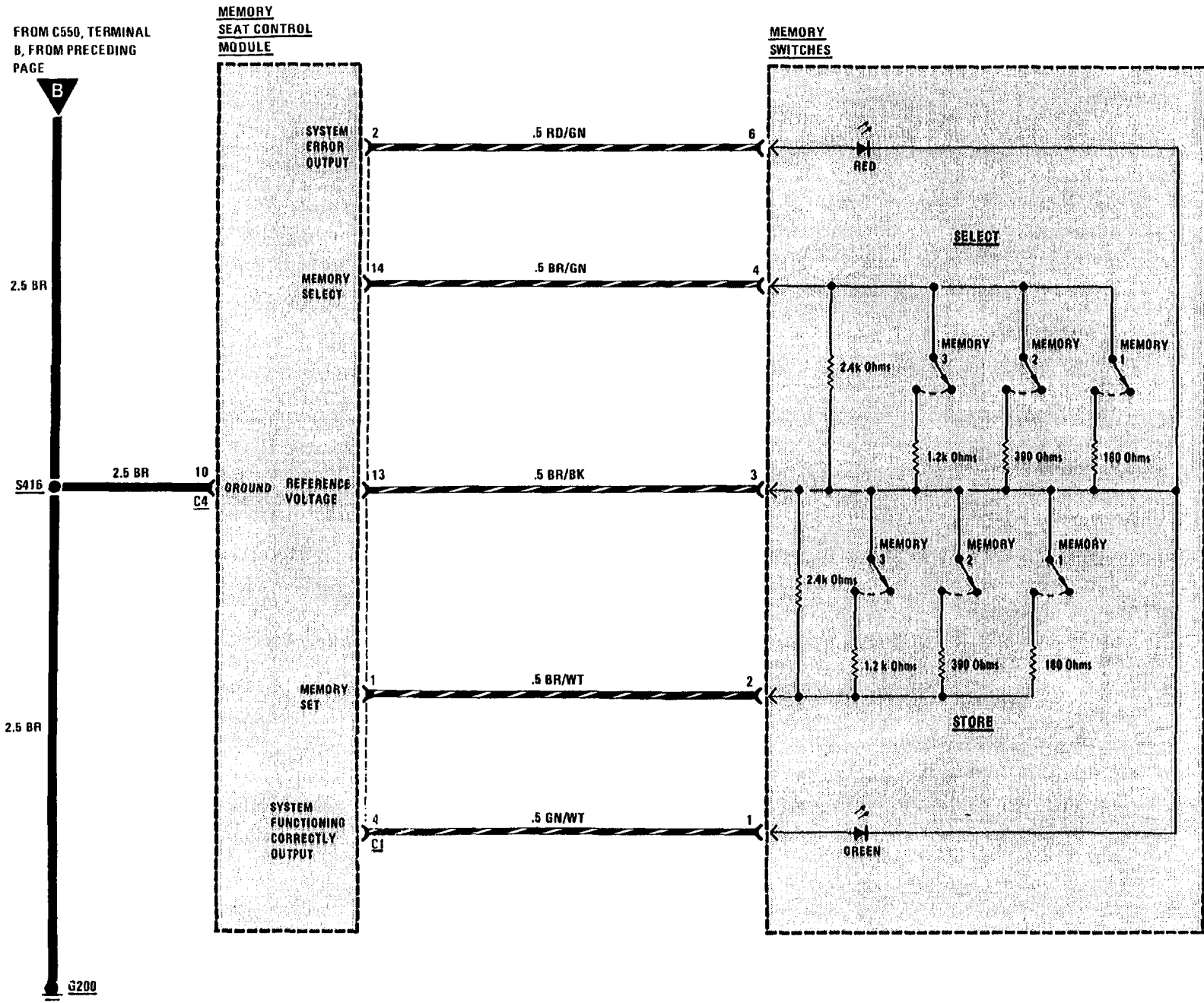

MEMORY SEAT

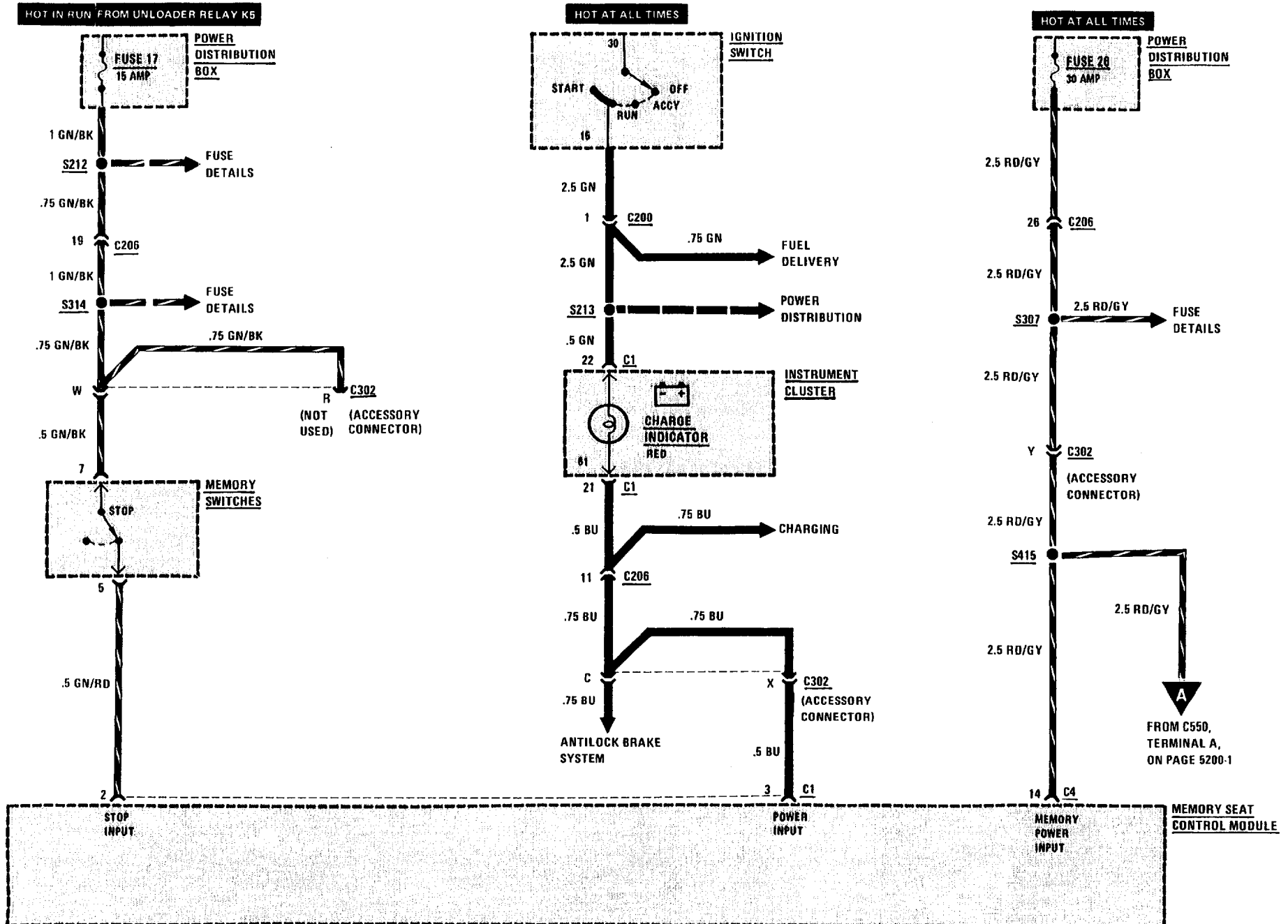

MEMORY SEAT

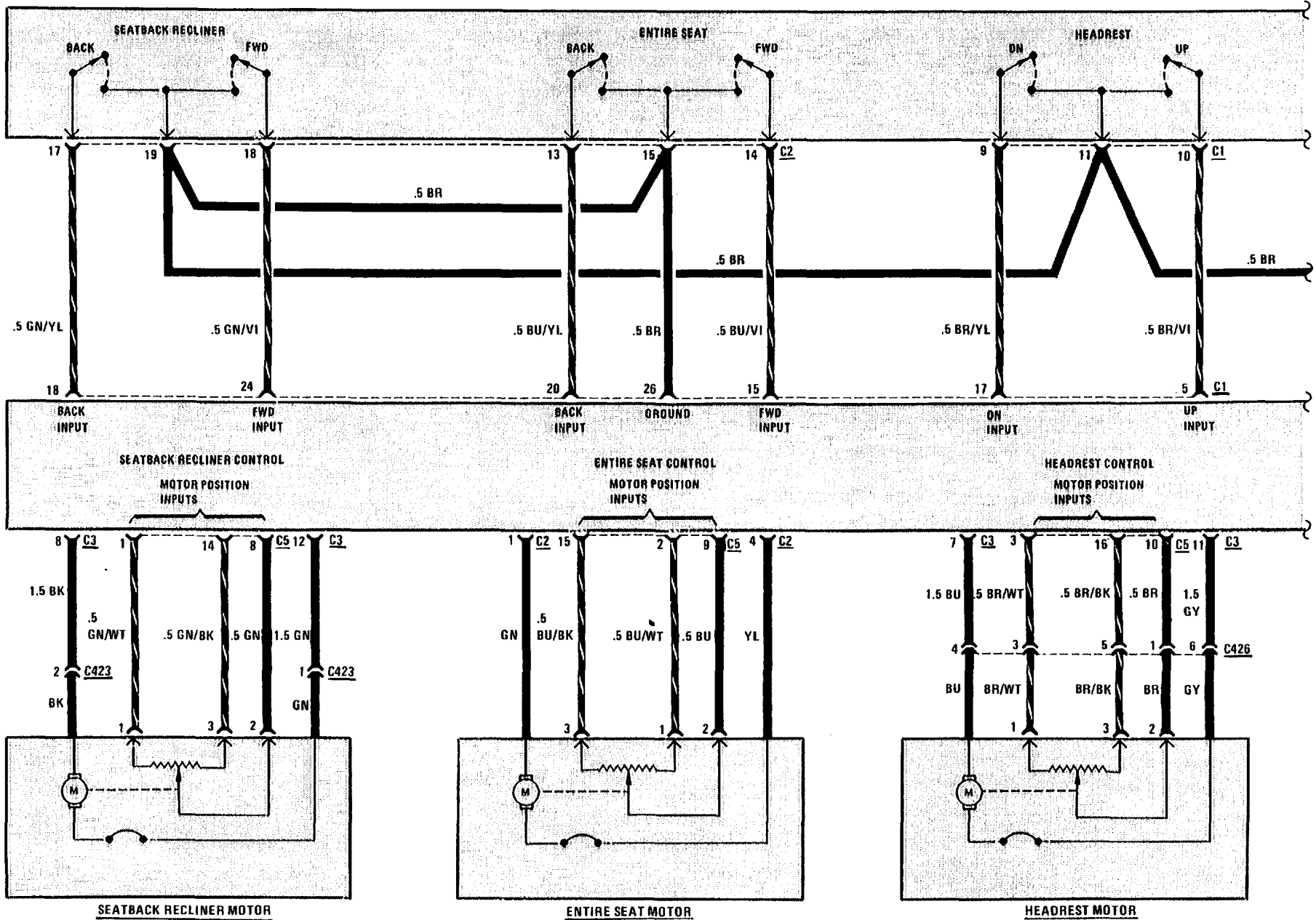

MEMORY SEAT

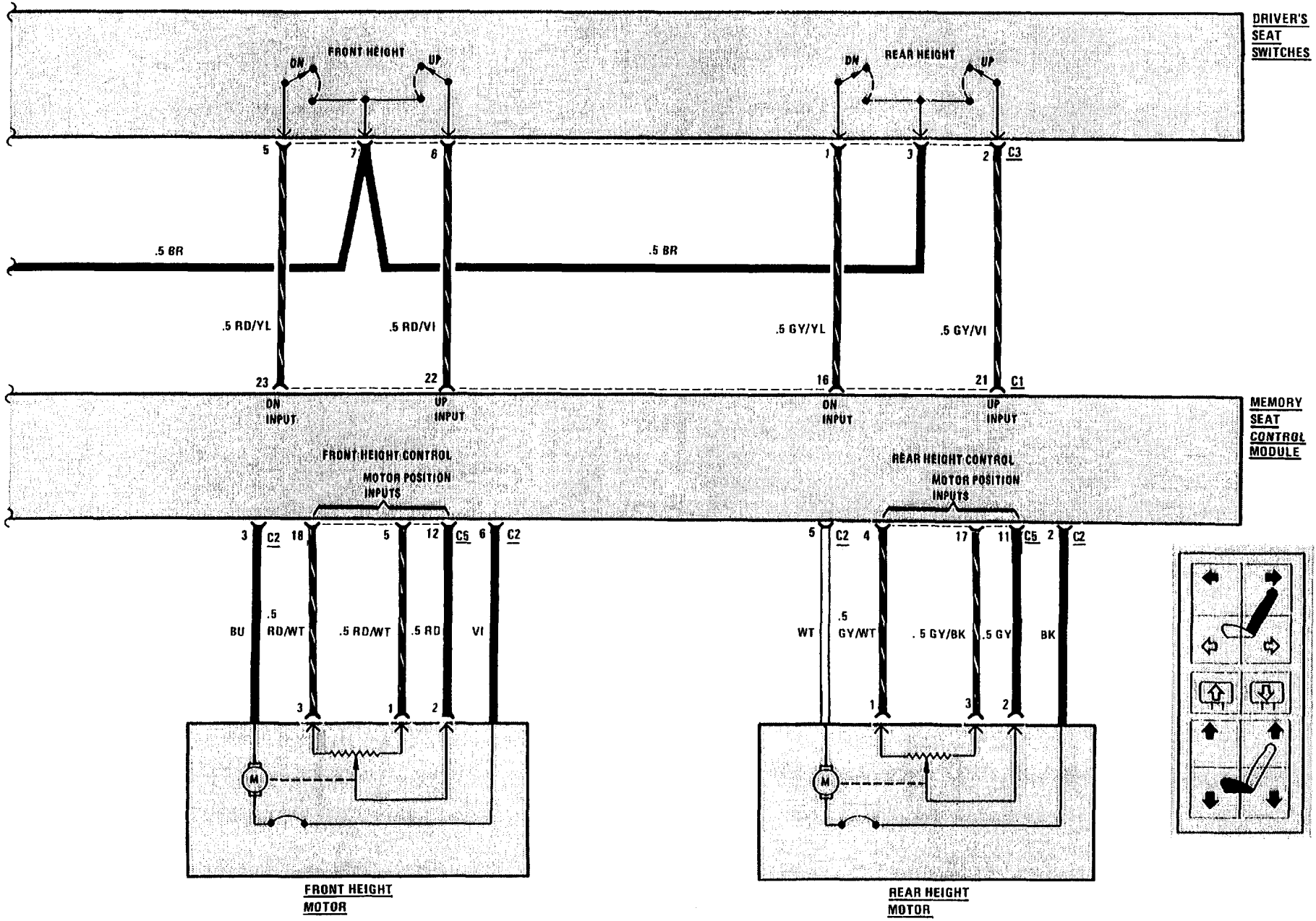

HEATED SEATS

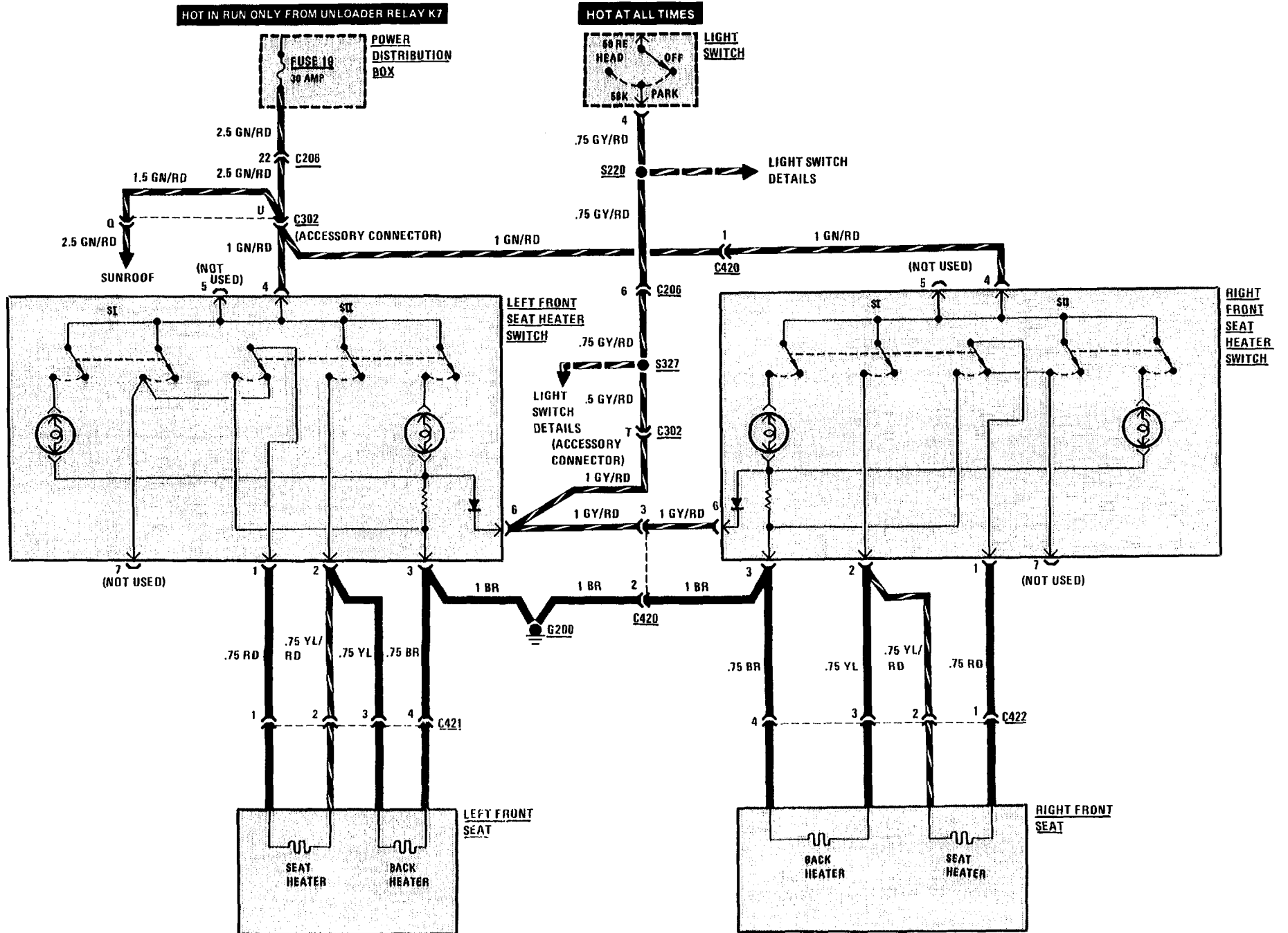

**EARLY PRODUCTION**

HOT IN RUN ONLY FROM UNLOADER RELAY K7

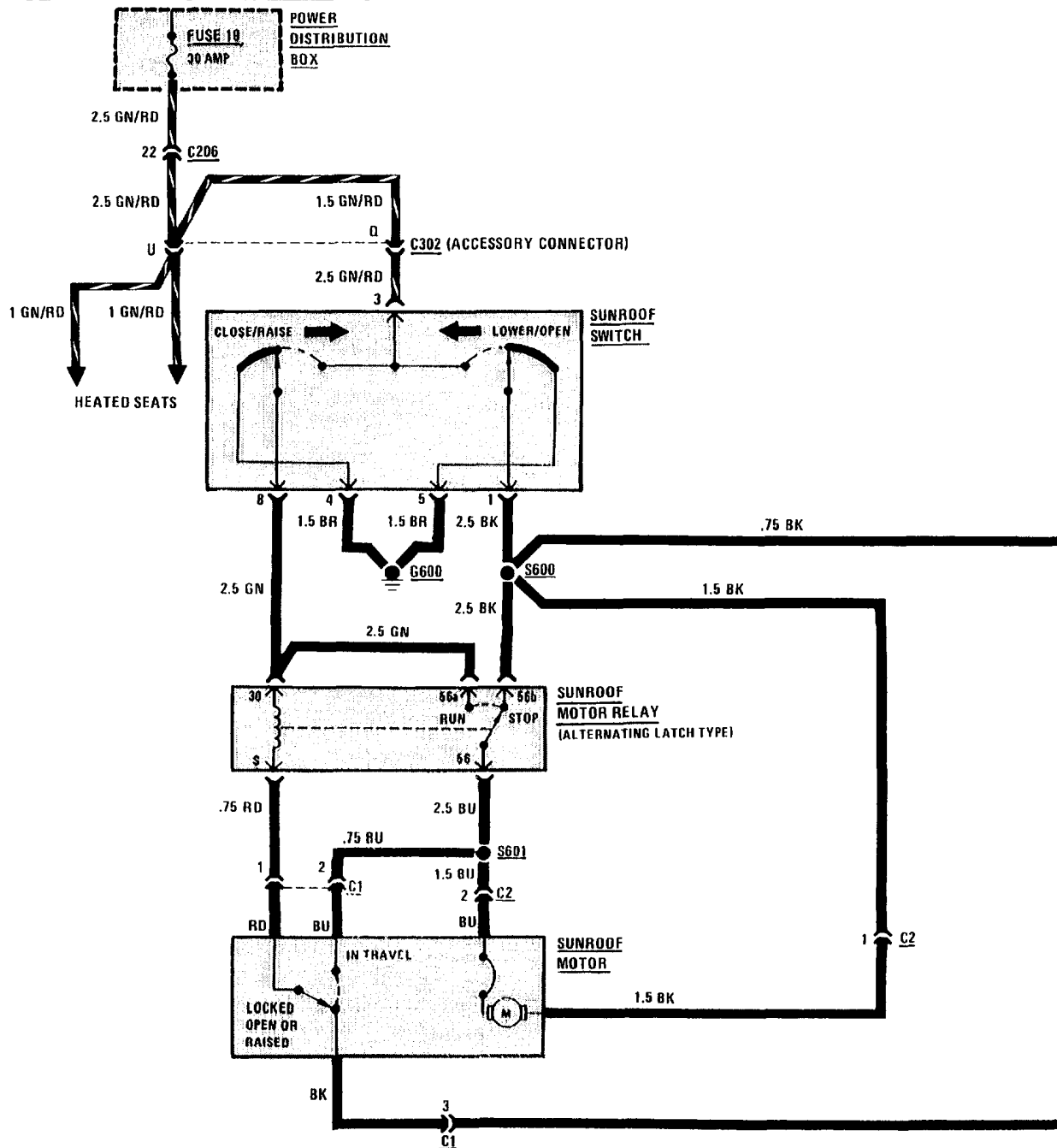

LATE PRODUCTION

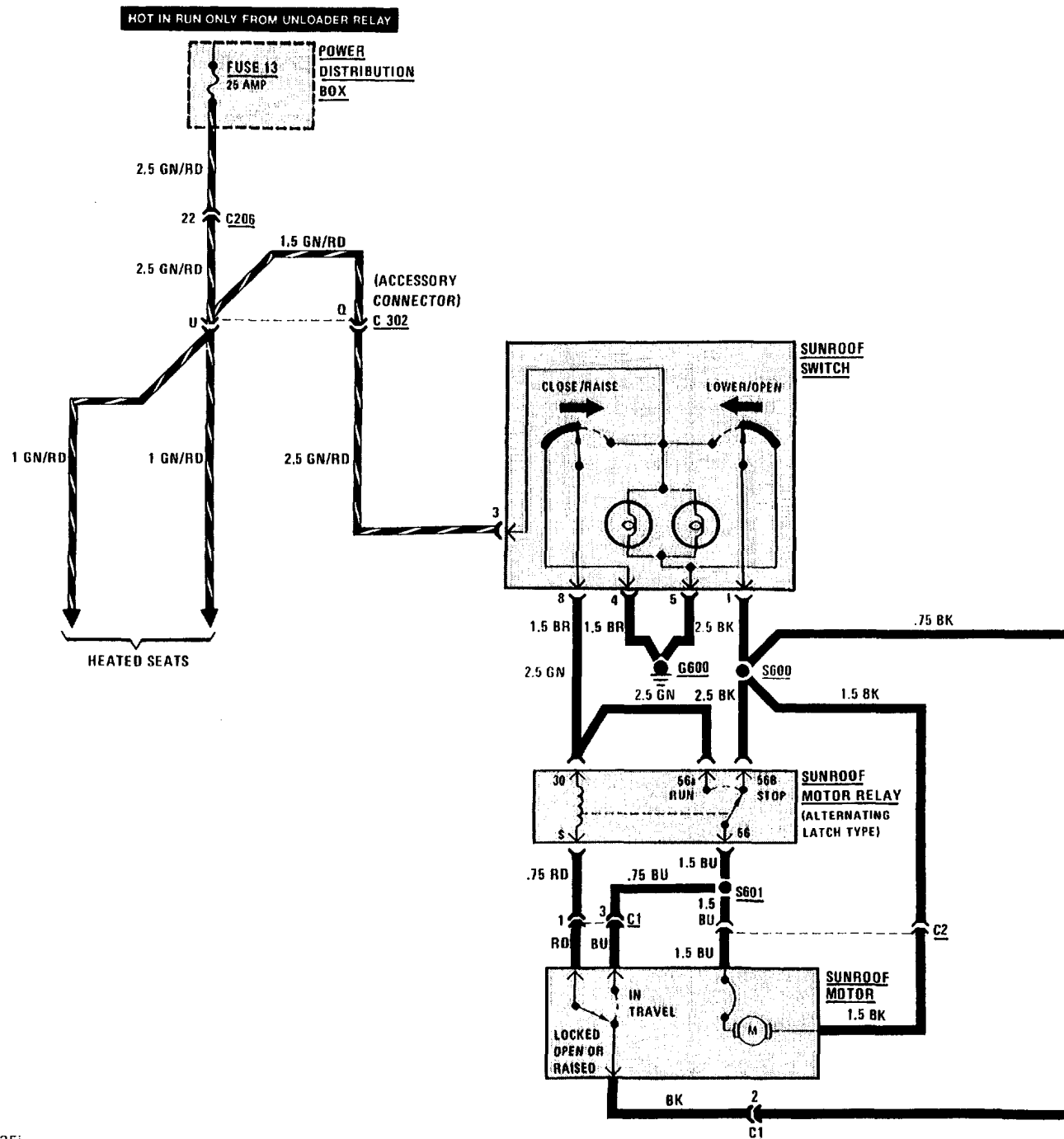





**CIGAR LIGHTERS/GLOVE BOX/AUTO-CHARGING FLASHLIGHT/MAP READING LIGHT**

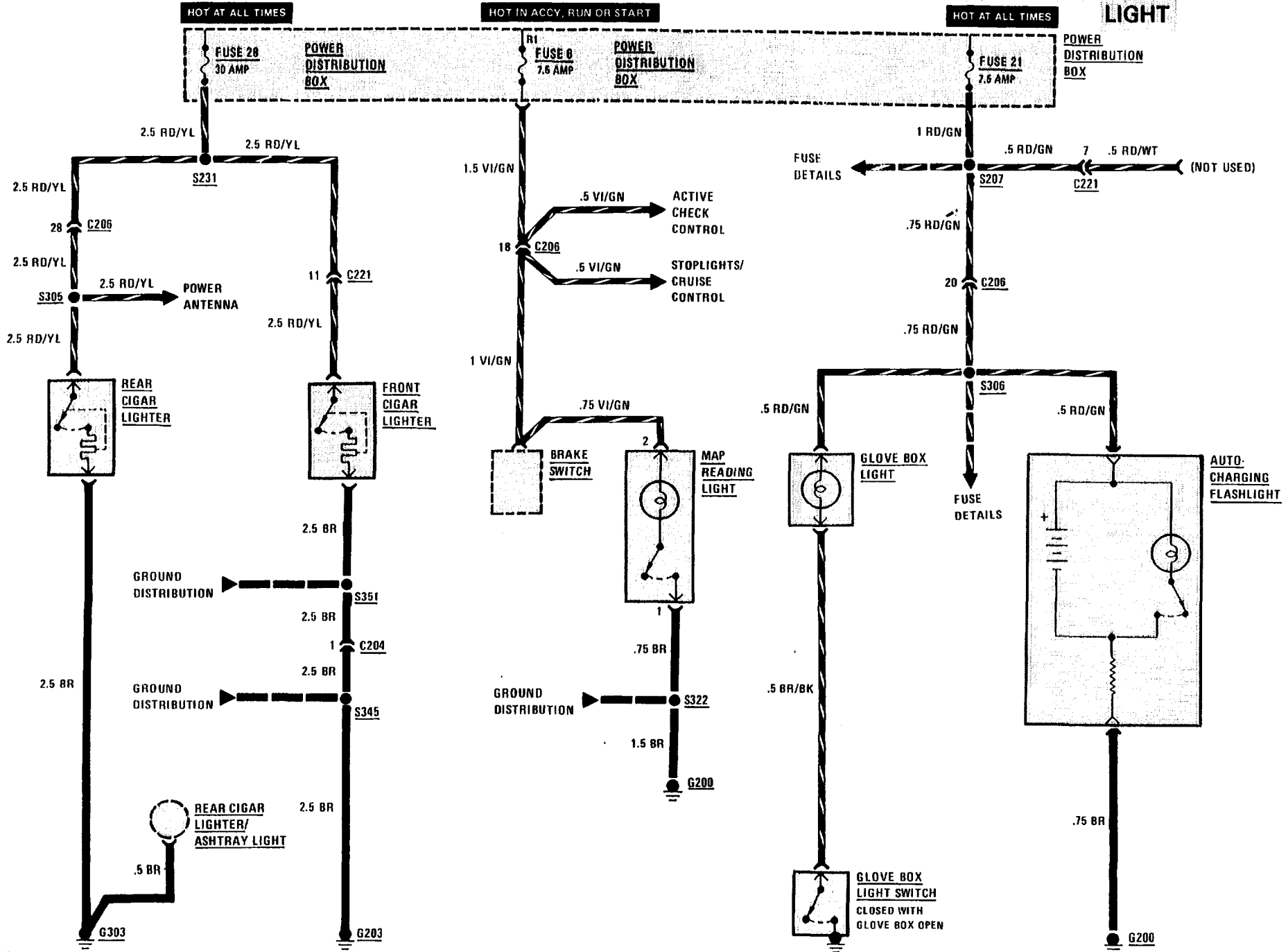

# 6100-2 BODY ELECTRICAL

## REAR WINDOW DEFOGGER

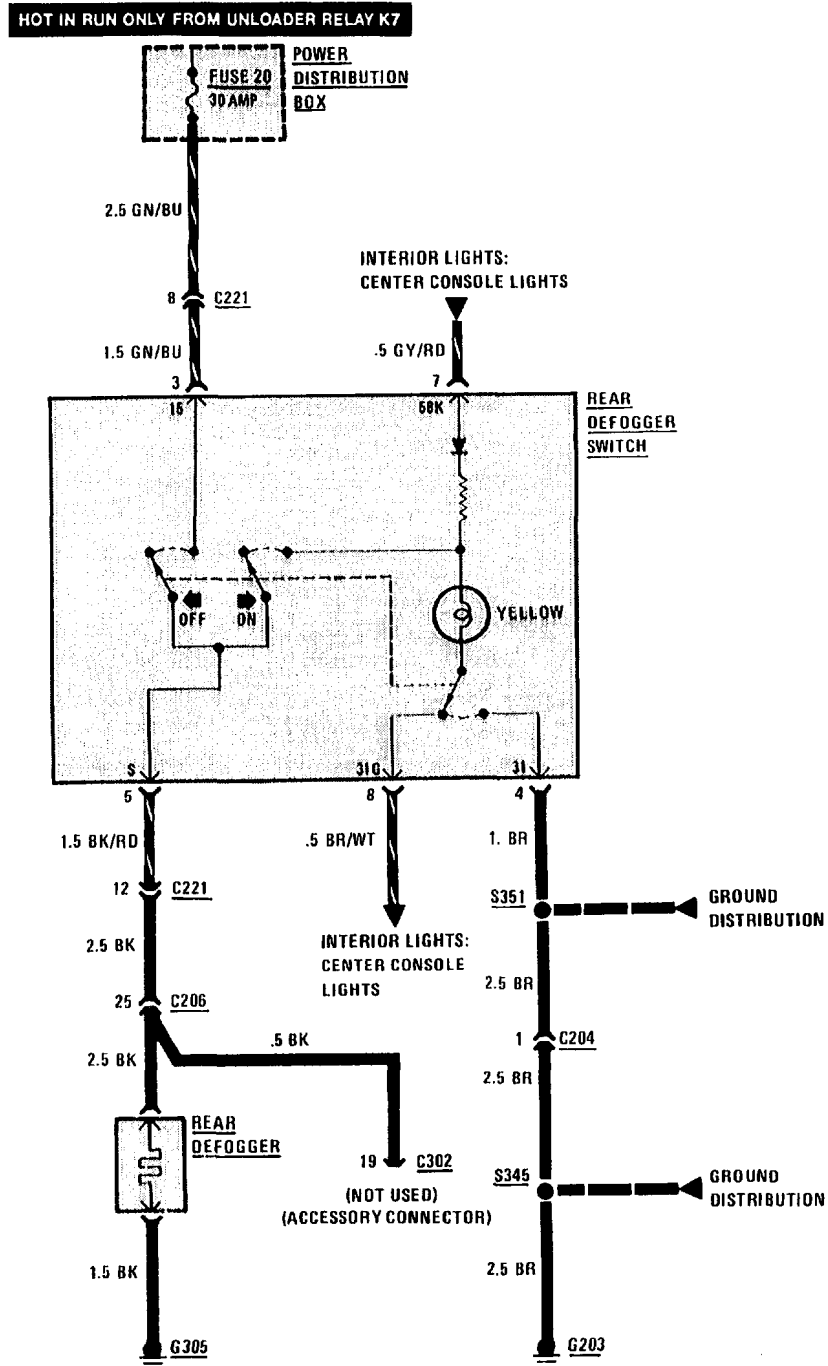

# 6131-0 IGNITION KEY/SEATBELT WARNINGS

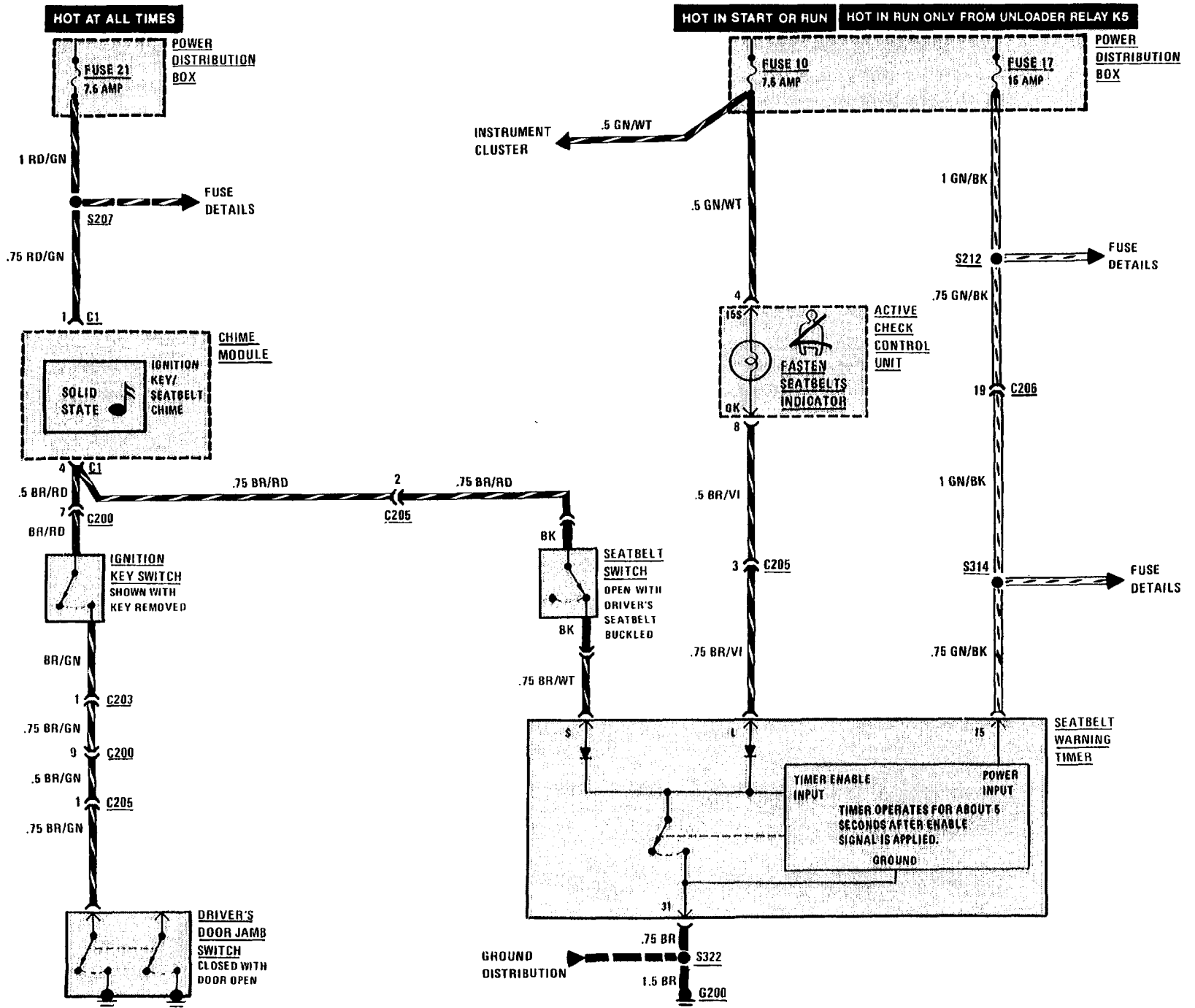



WINDSHIELD WASHER JET HEATERS

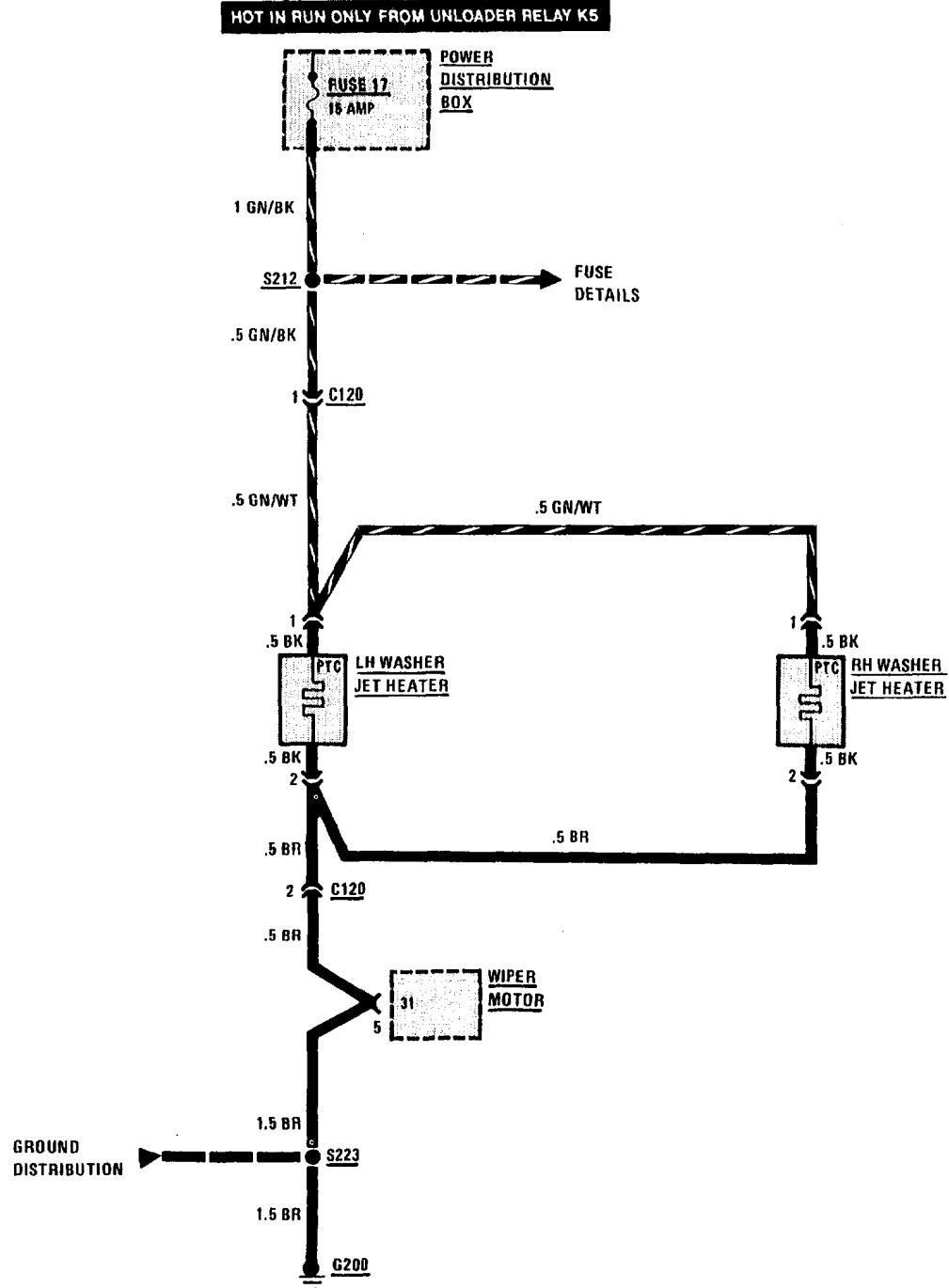

# 6210-0 INSTRUMENT CLUSTER

## SPEEDOMETER/GAUGES/WARNING INDICATORS EARLY PRODUCTION

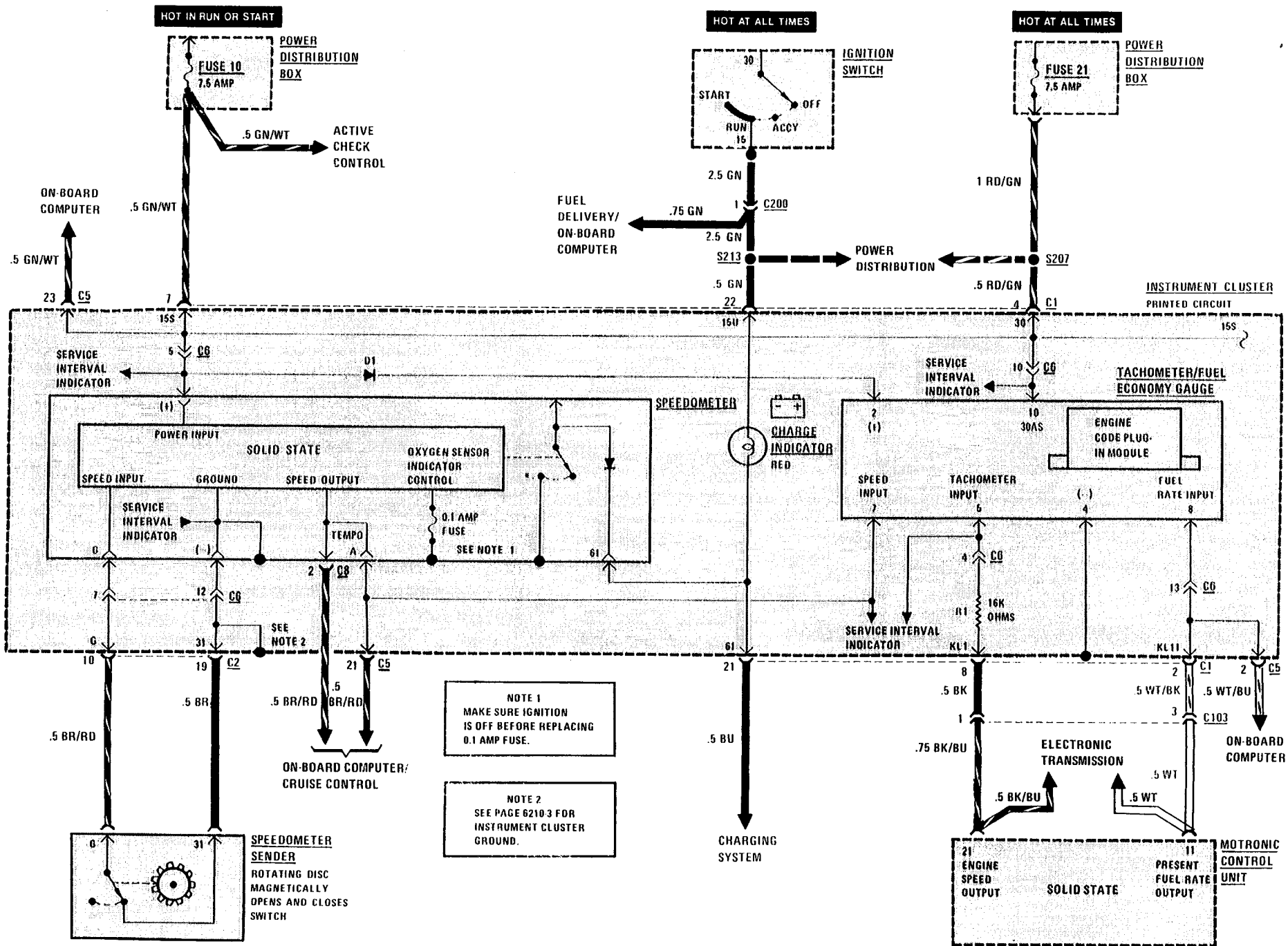

GAUGES/WARNING INDICATORS EARLY PRODUCTION

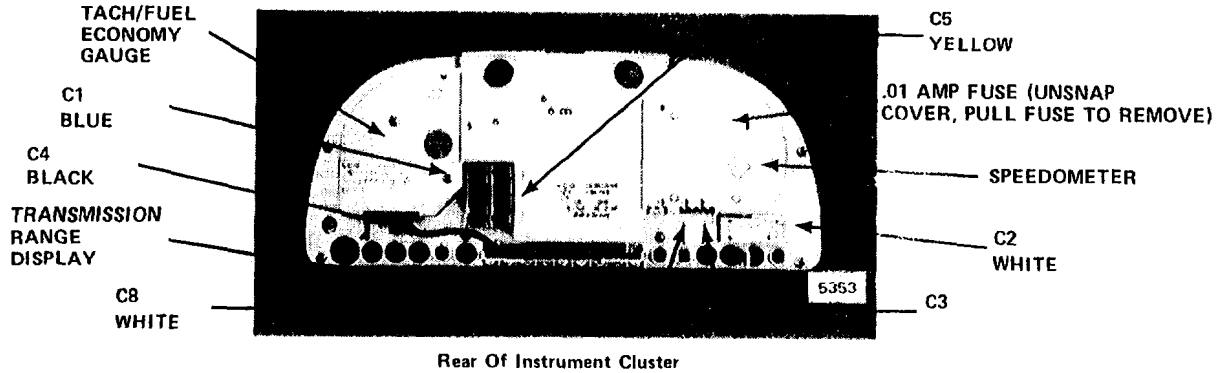

Rear Of Instrument Cluster

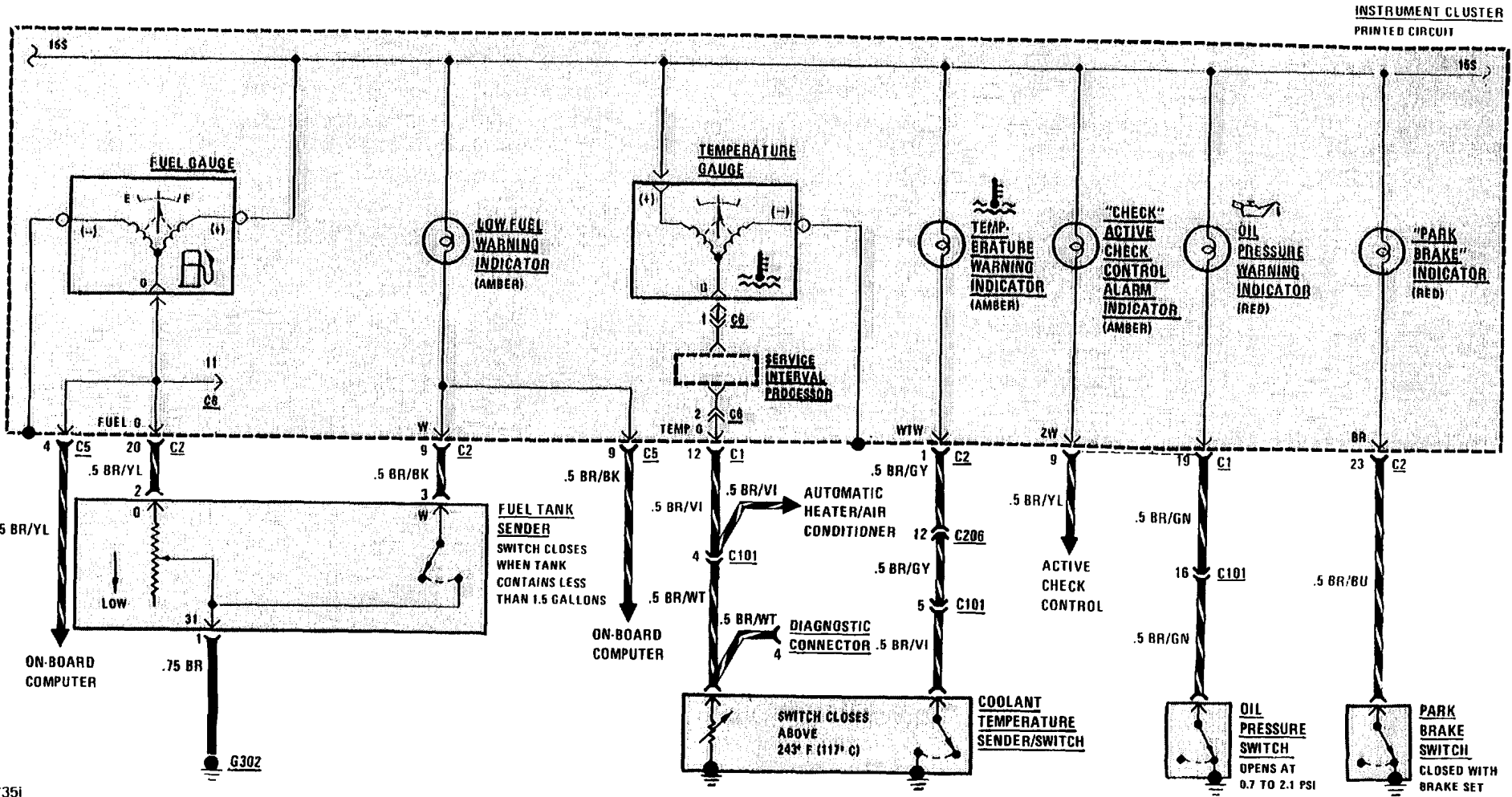







SPEEDOMETER/GAUGES/WARNING INDICATORS LATE PRODUCTION

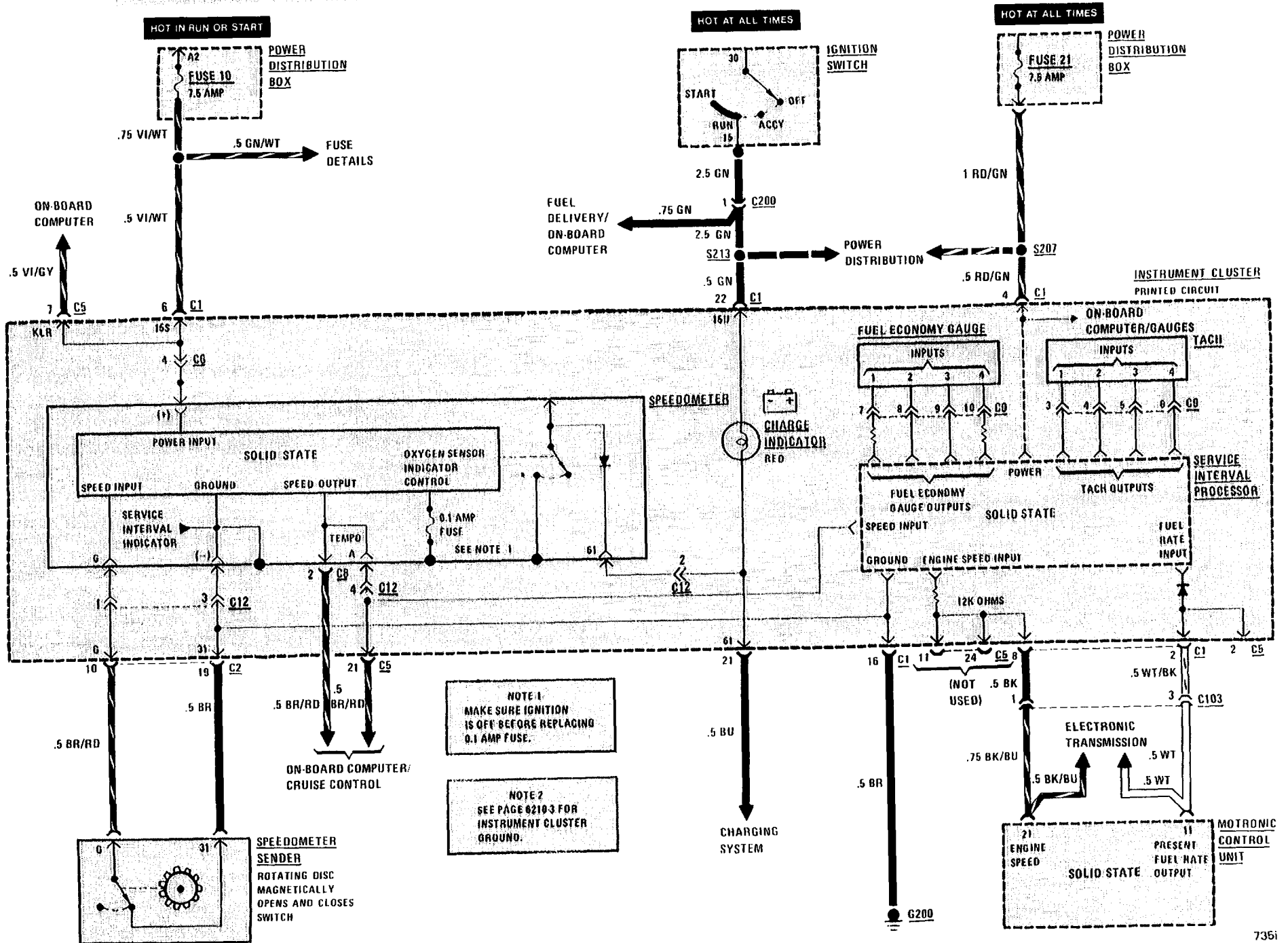

GAUGES/WARNING INDICATORS LATE PRODUCTION

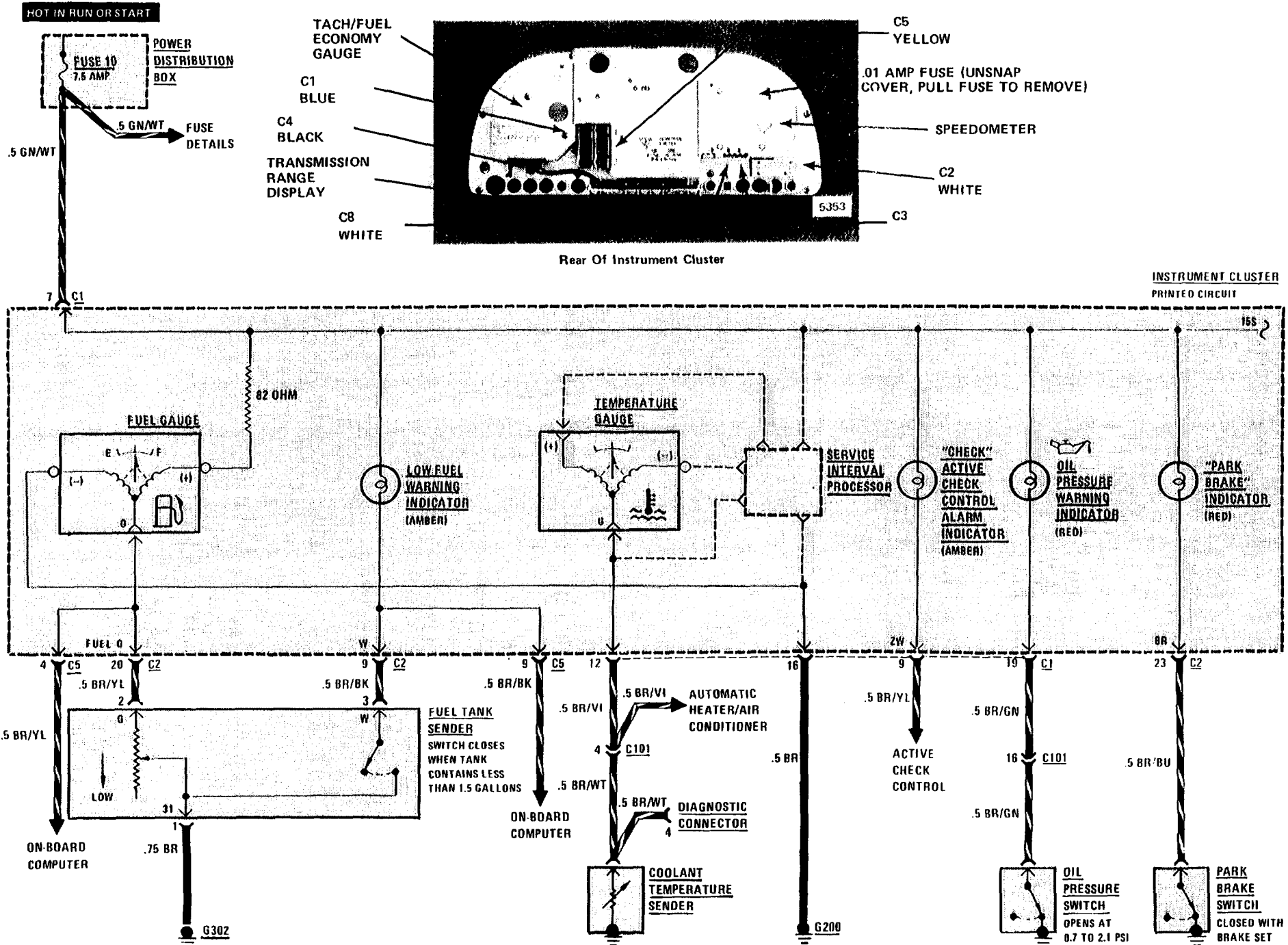



GAUGES/WARNING INDICATORS LATE PRODUCTION

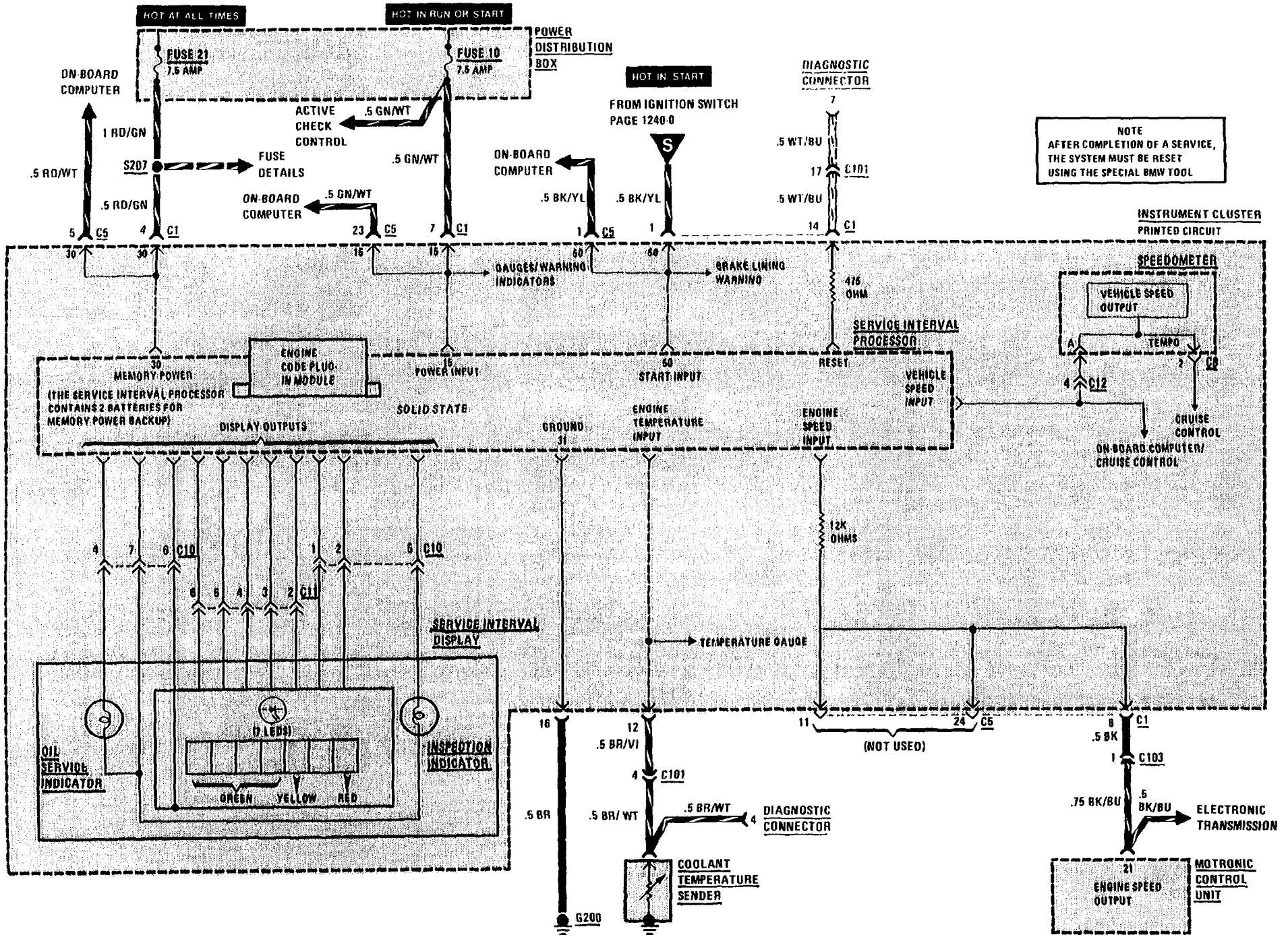

**ACTIVE CHECK CONTROL**

1. When the Ignition Switch is initially placed in "Run," the Active Check Control Arm Indicator flashes, and the Active Check Control Unit Brake Light LED and panel light illuminate for test purposes. Depressing the brake pedal clears the display.
2. When the Ignition Switch is placed in "Run," fault monitoring begins. To monitor the low beams, rear lights, or license lights, those circuits must be on. The brake lights are monitored only while the brake pedal is depressed.
3. When a fault occurs, the alarm indicator flashes, the appropriate LED fault indicator lights, and the panel light goes on for five seconds. Depressing the test button will clear the alarm indicator, but the LED fault indicator remains on.

4. To test the unit, depress the test button. The LED fault indicators and the panel lights should go on.



Figure 1 - Active Check Control Unit (Dash, Left Of Steering Column)

(For Component Locations See Page 201)

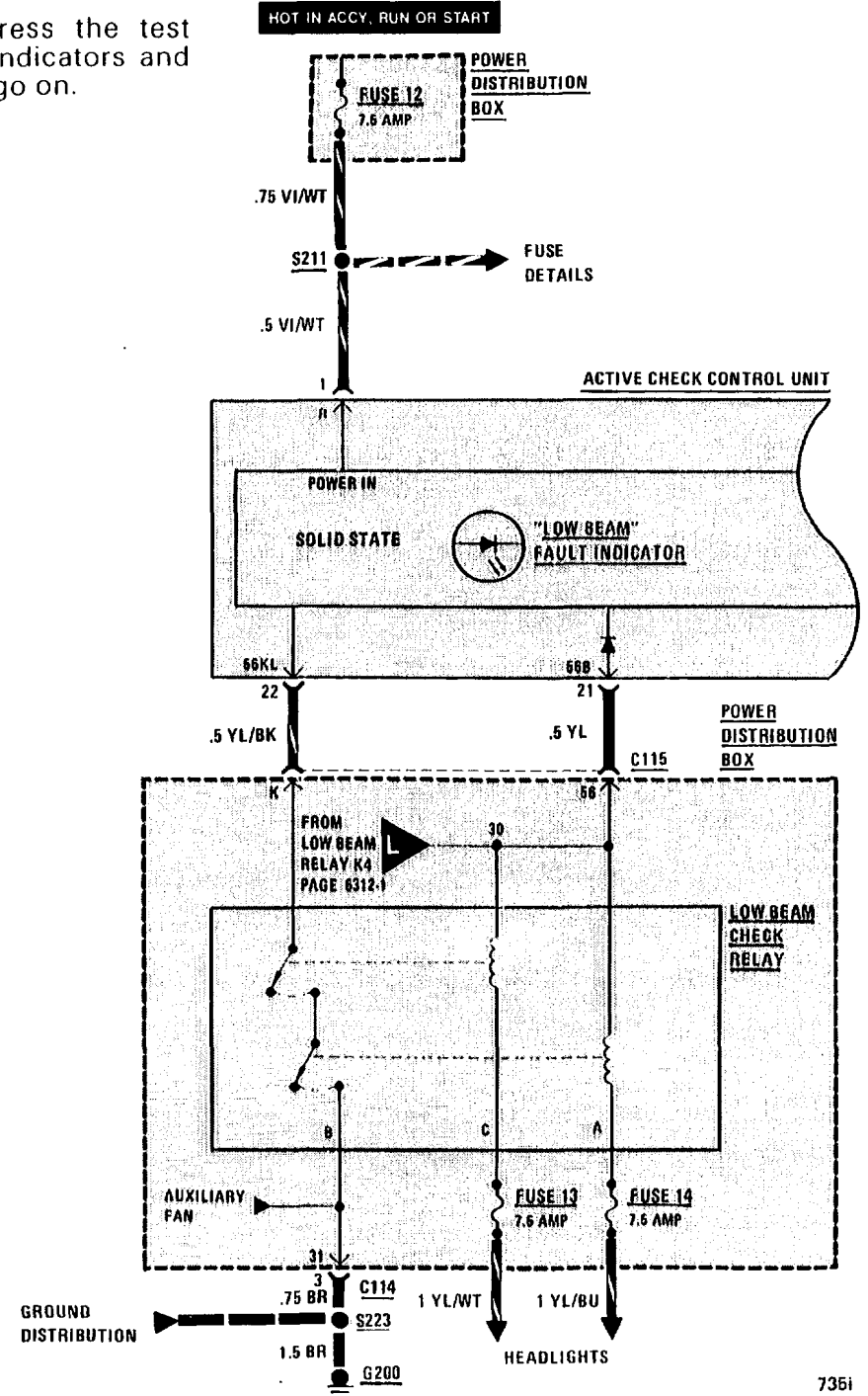





# 6216-2 ACTIVE CHECK CONTROL

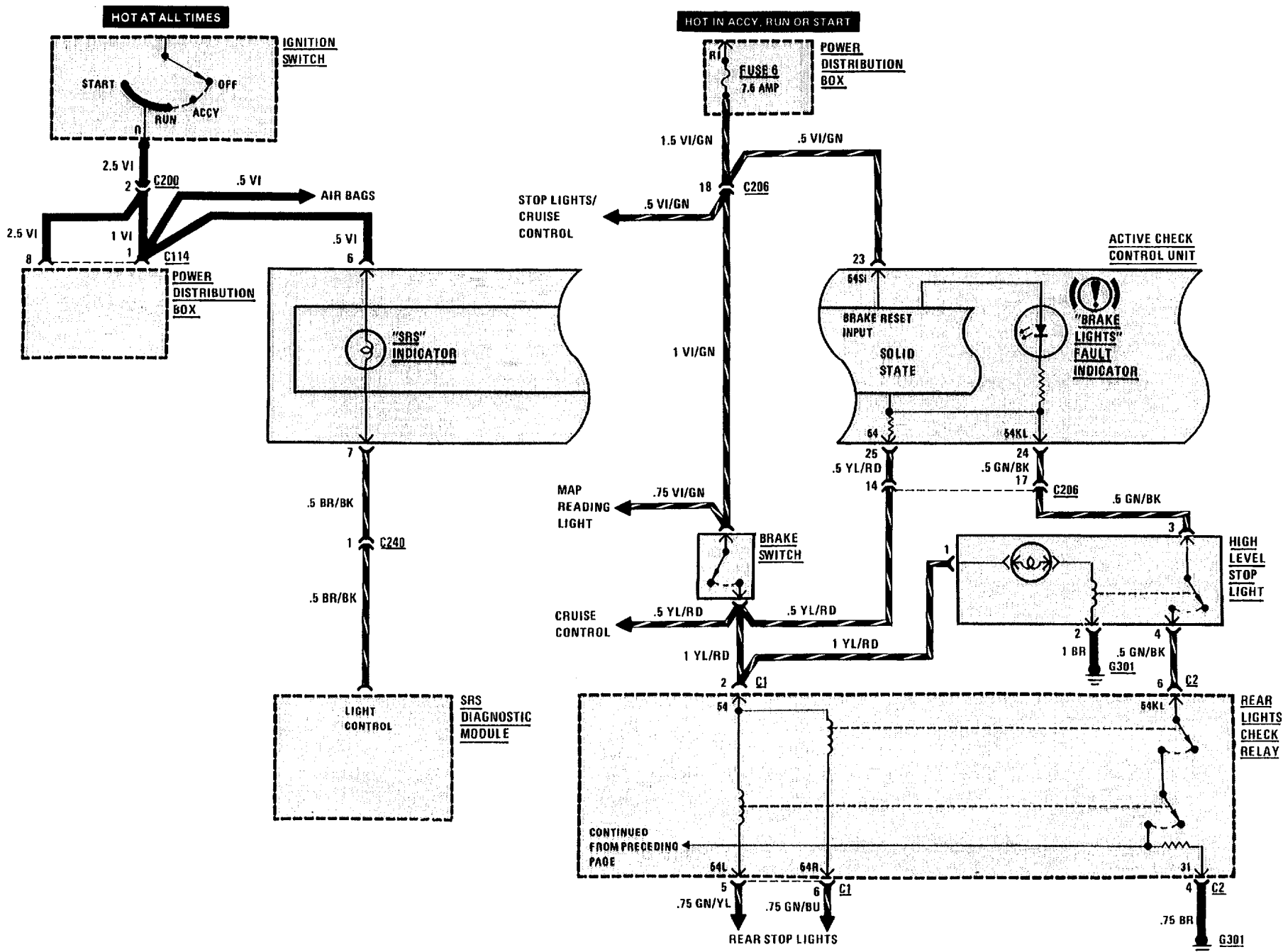

# ACTIVE CHECK CONTROL 6216-3

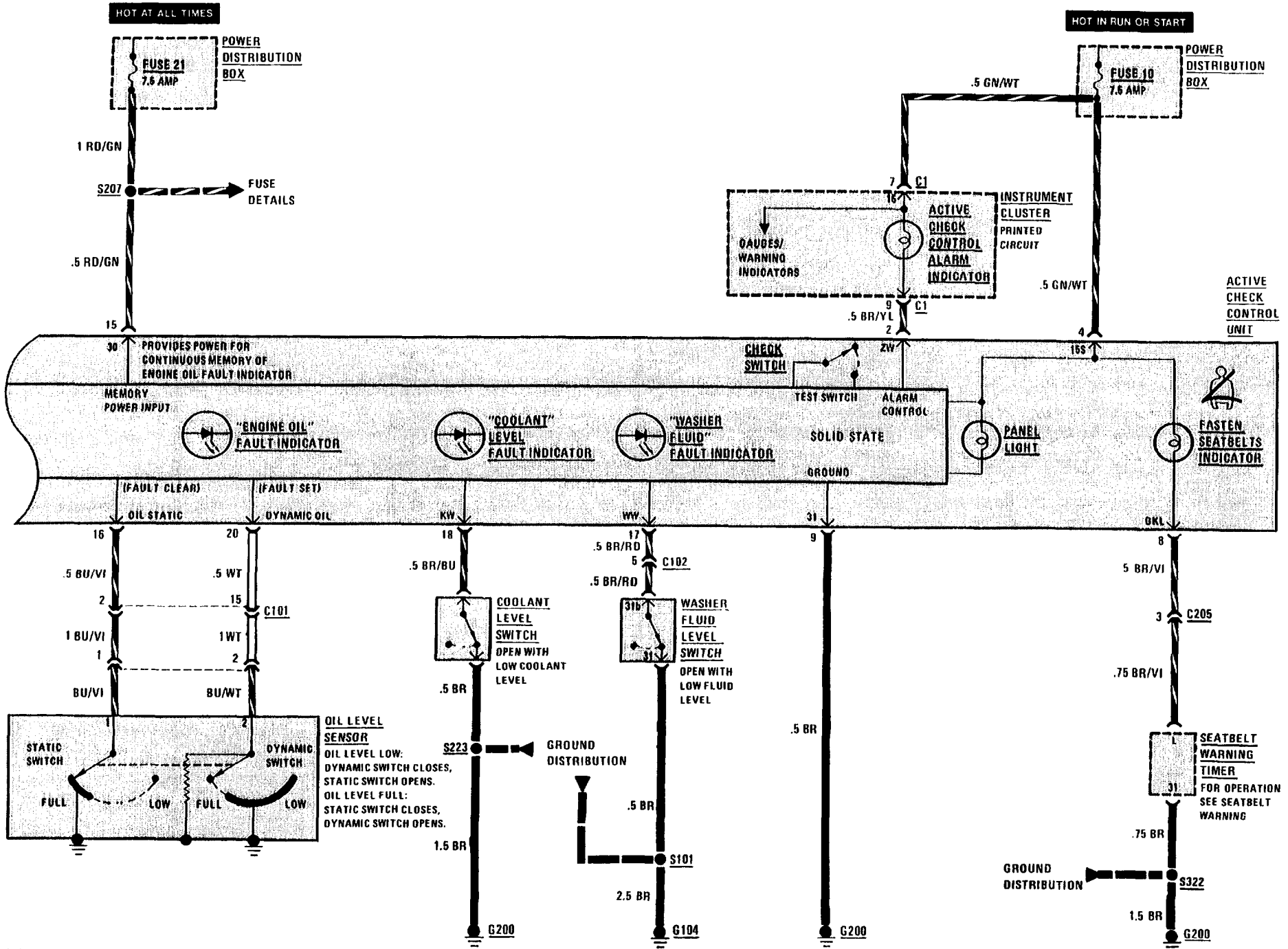



LIGHTS: DASH/TRANSMISSION RANGE

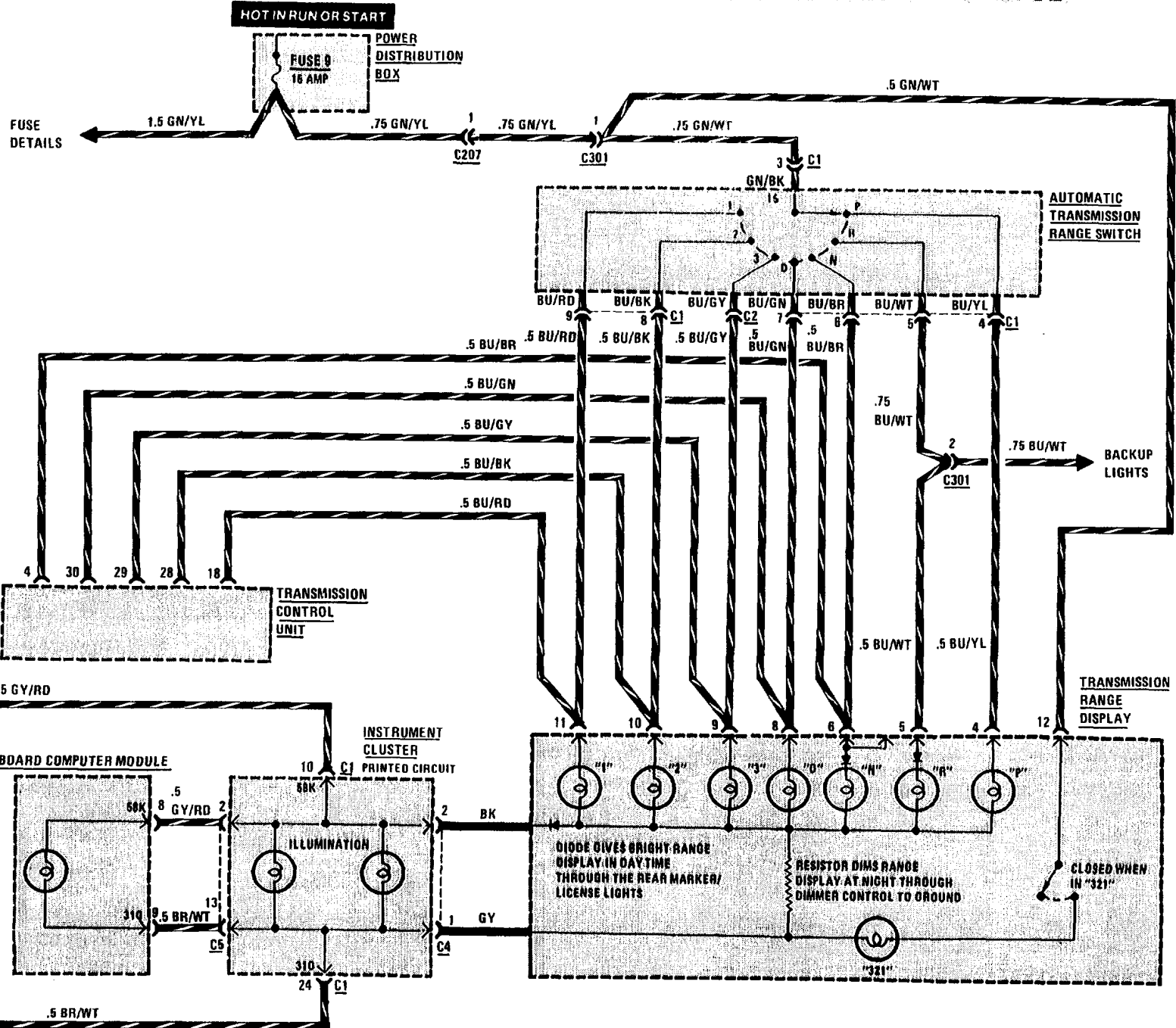

# 6300-2 LIGHT SWITCH DETAILS

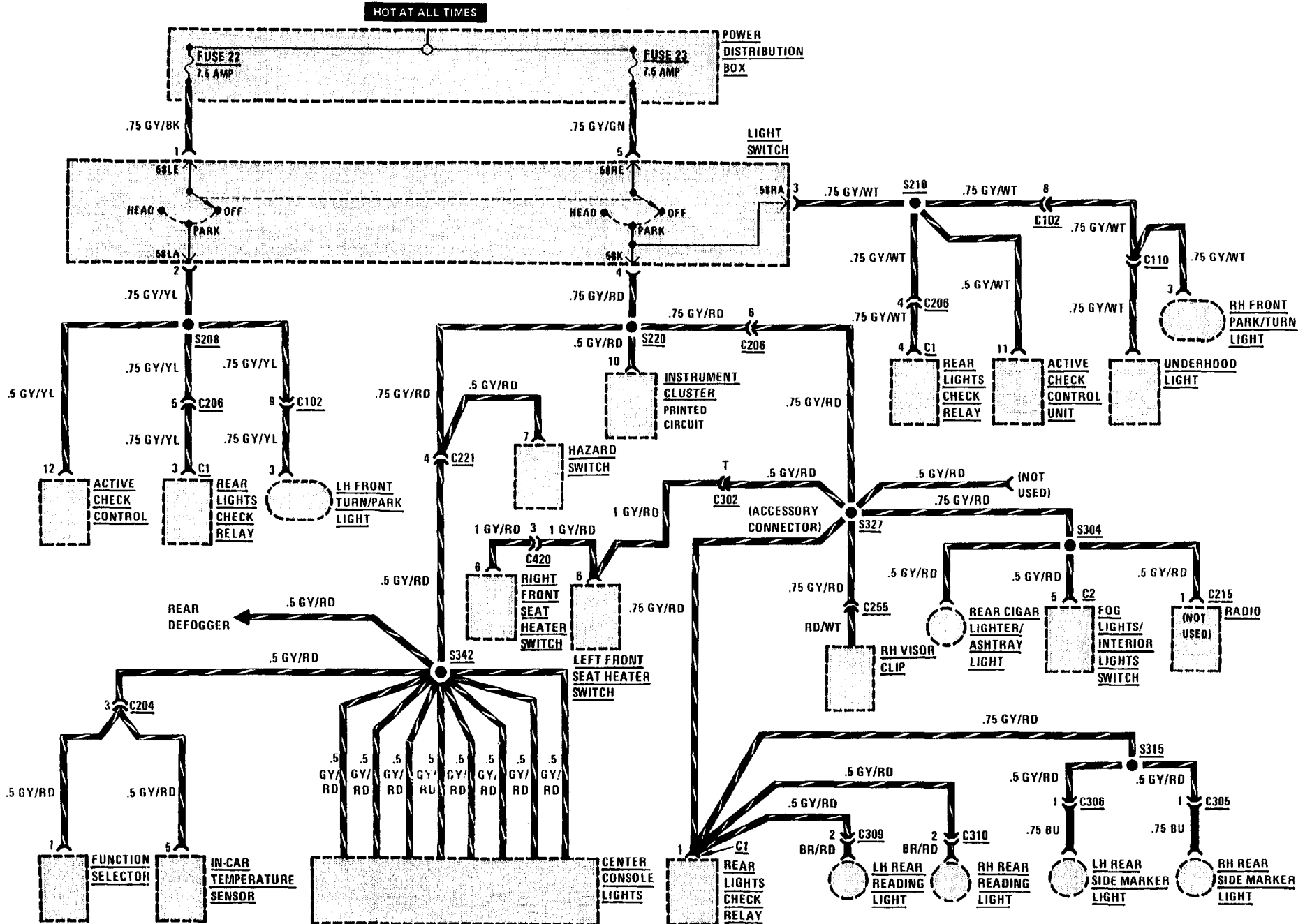



HEADLIGHTS (POWER)

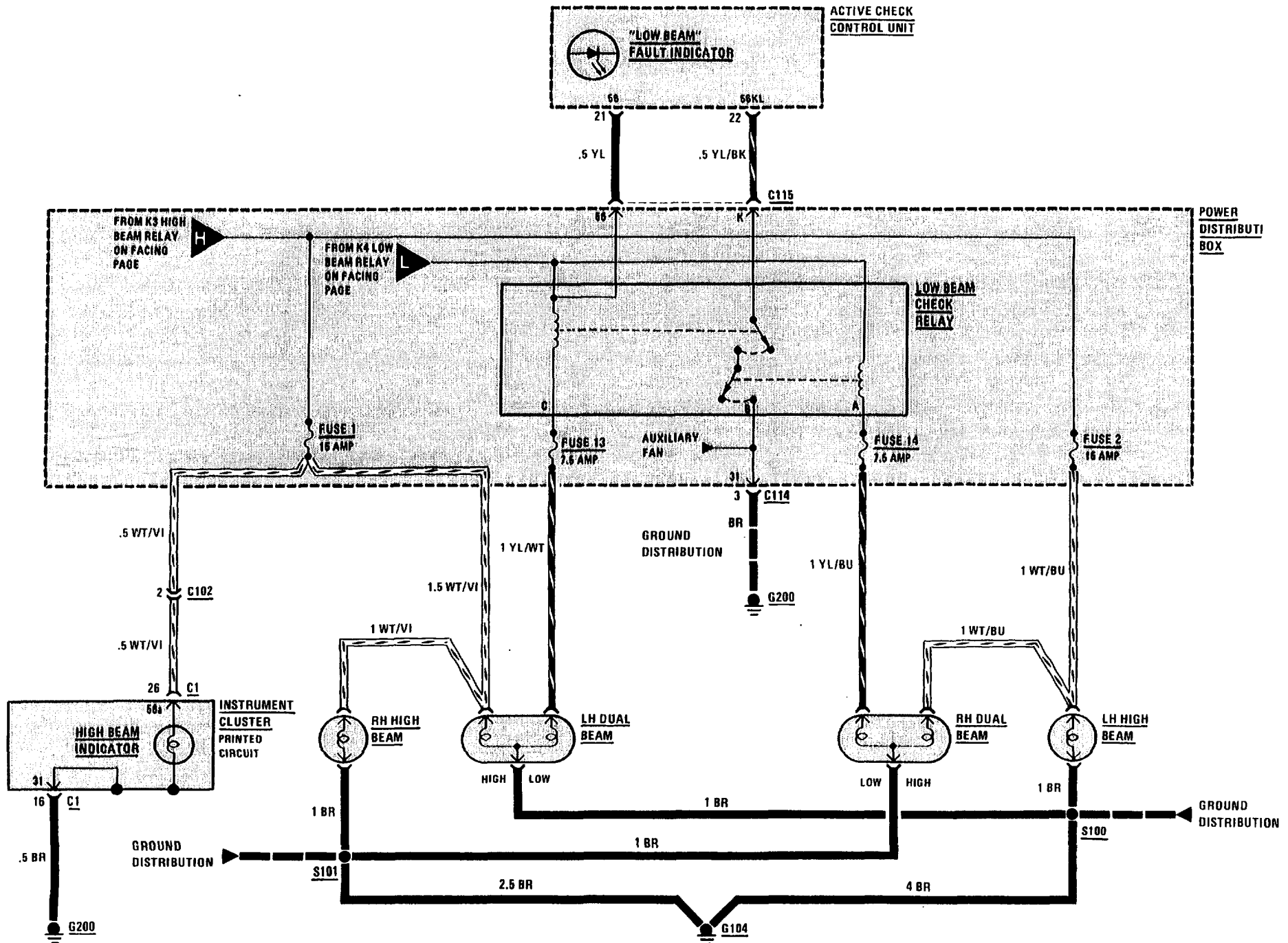

# 6313-0 TURN/HAZARD LIGHTS

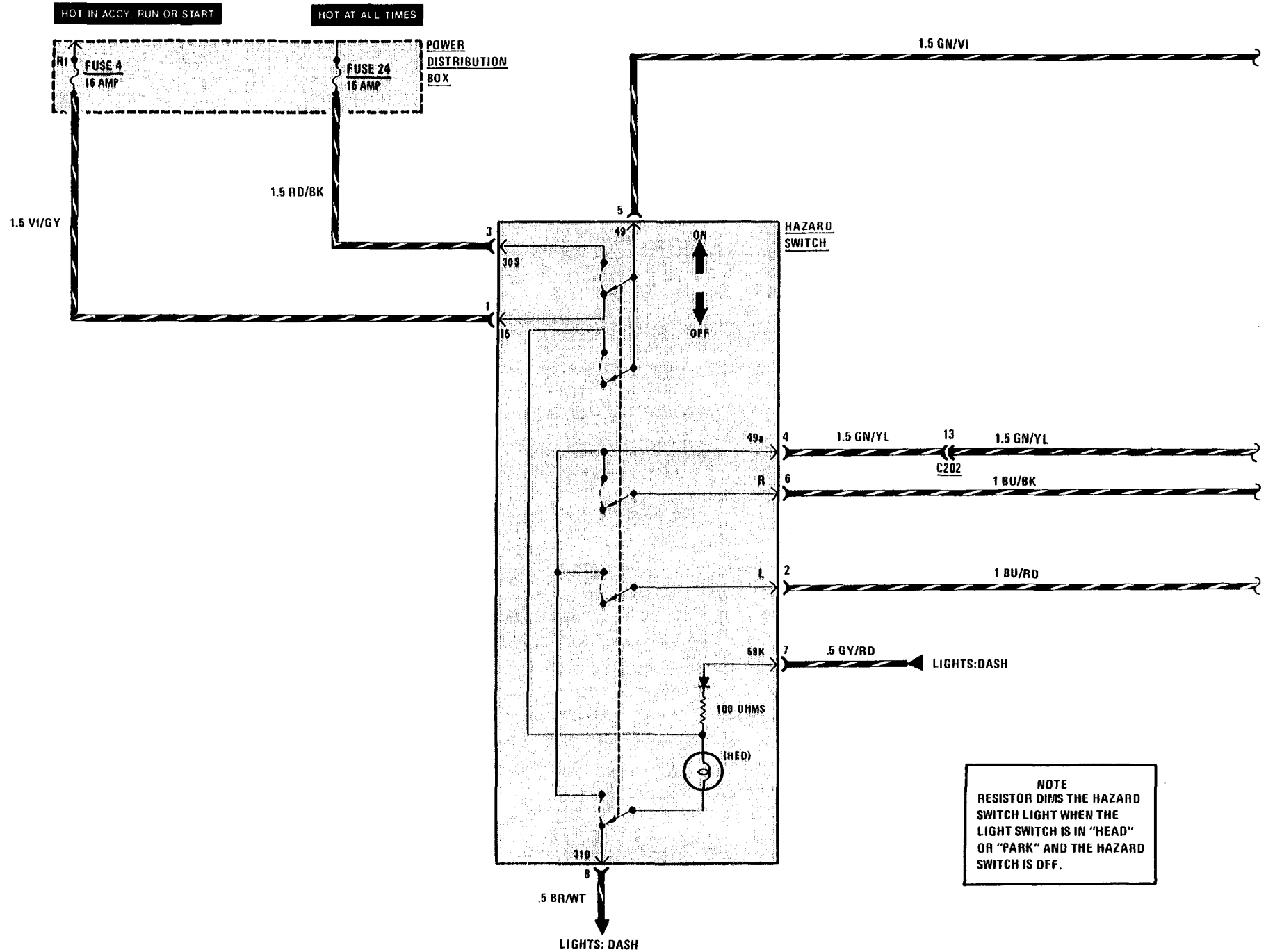



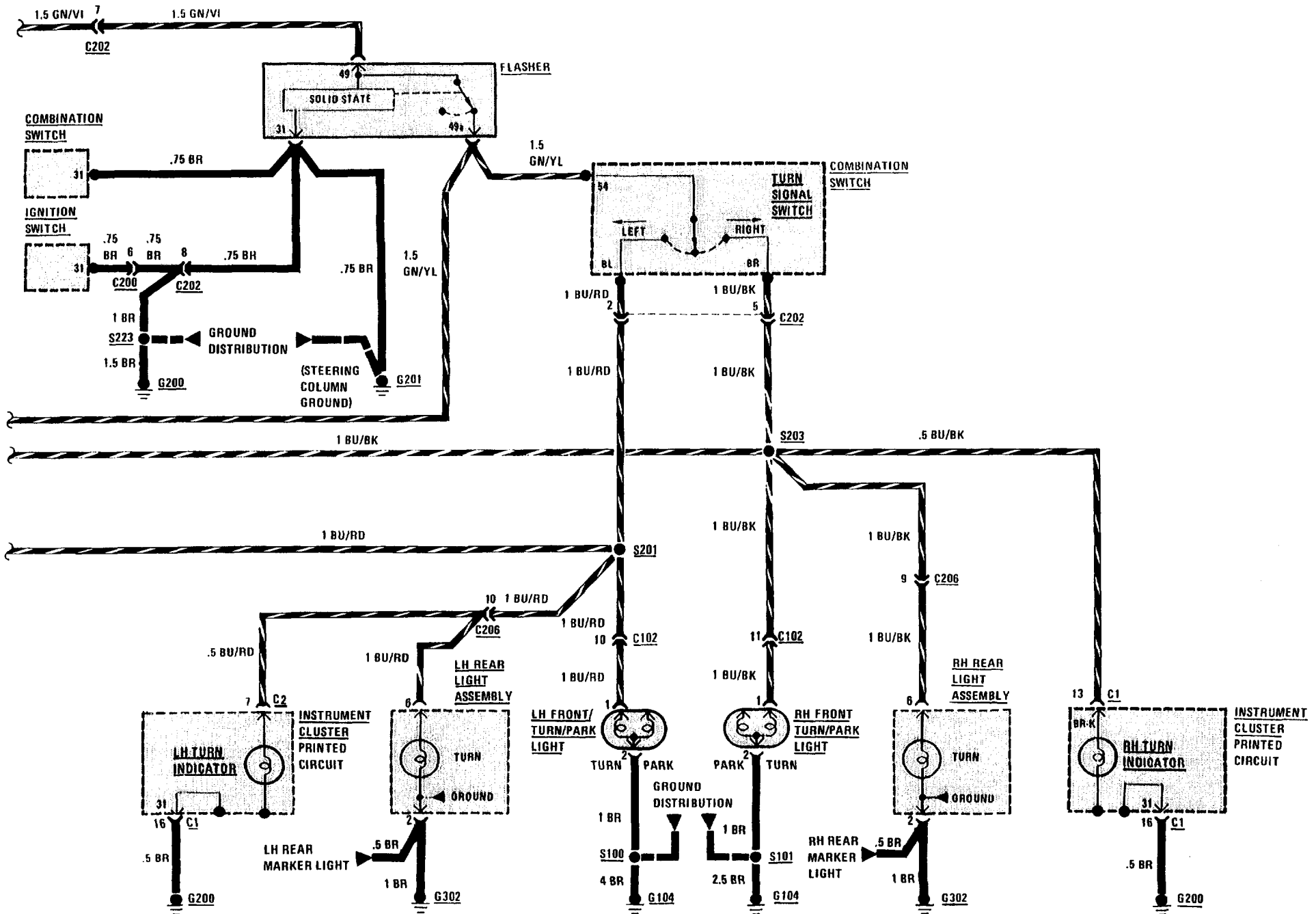





# 6322-0 BACKUP LIGHTS

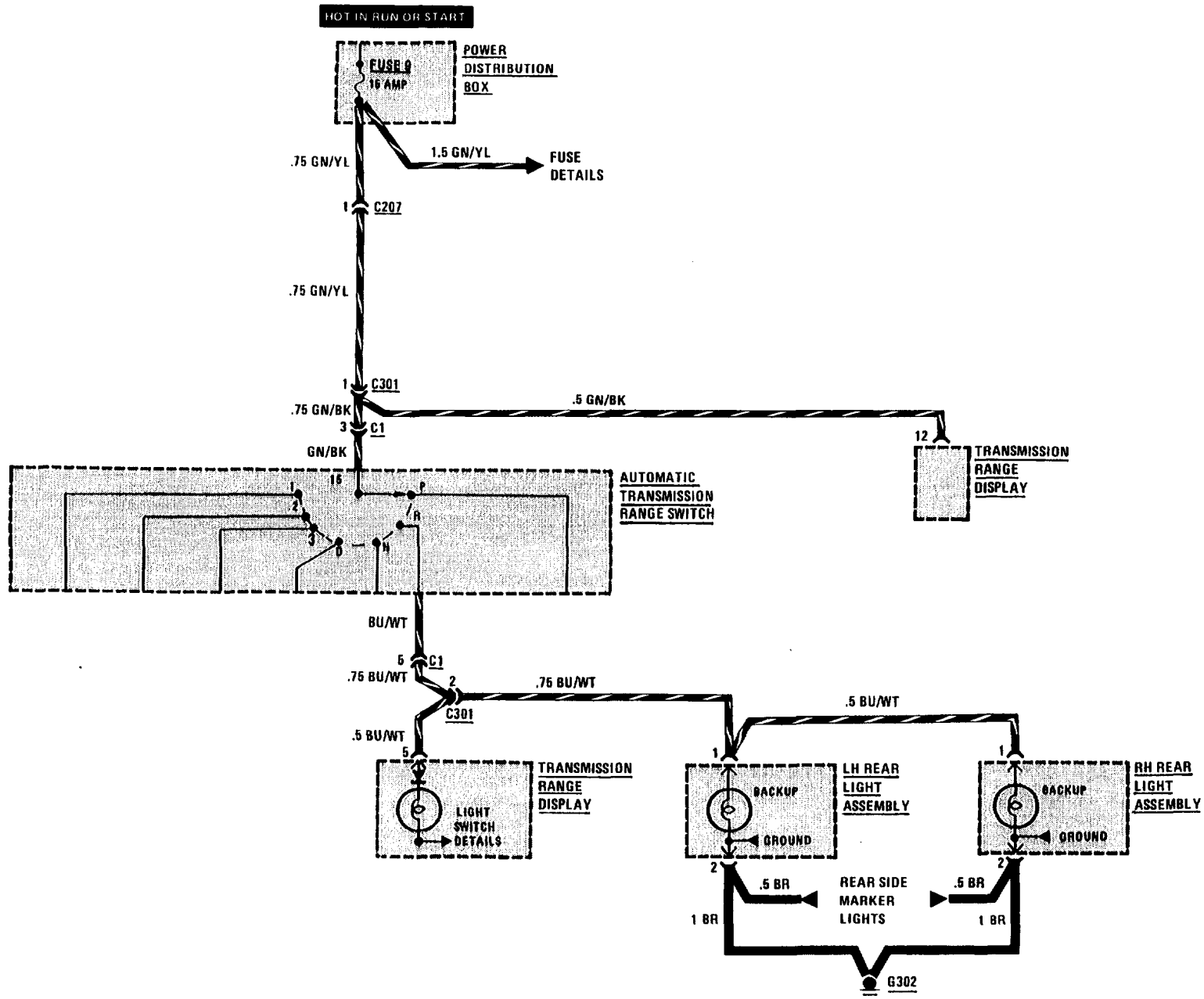



INTERIOR LIGHTS (DOME)

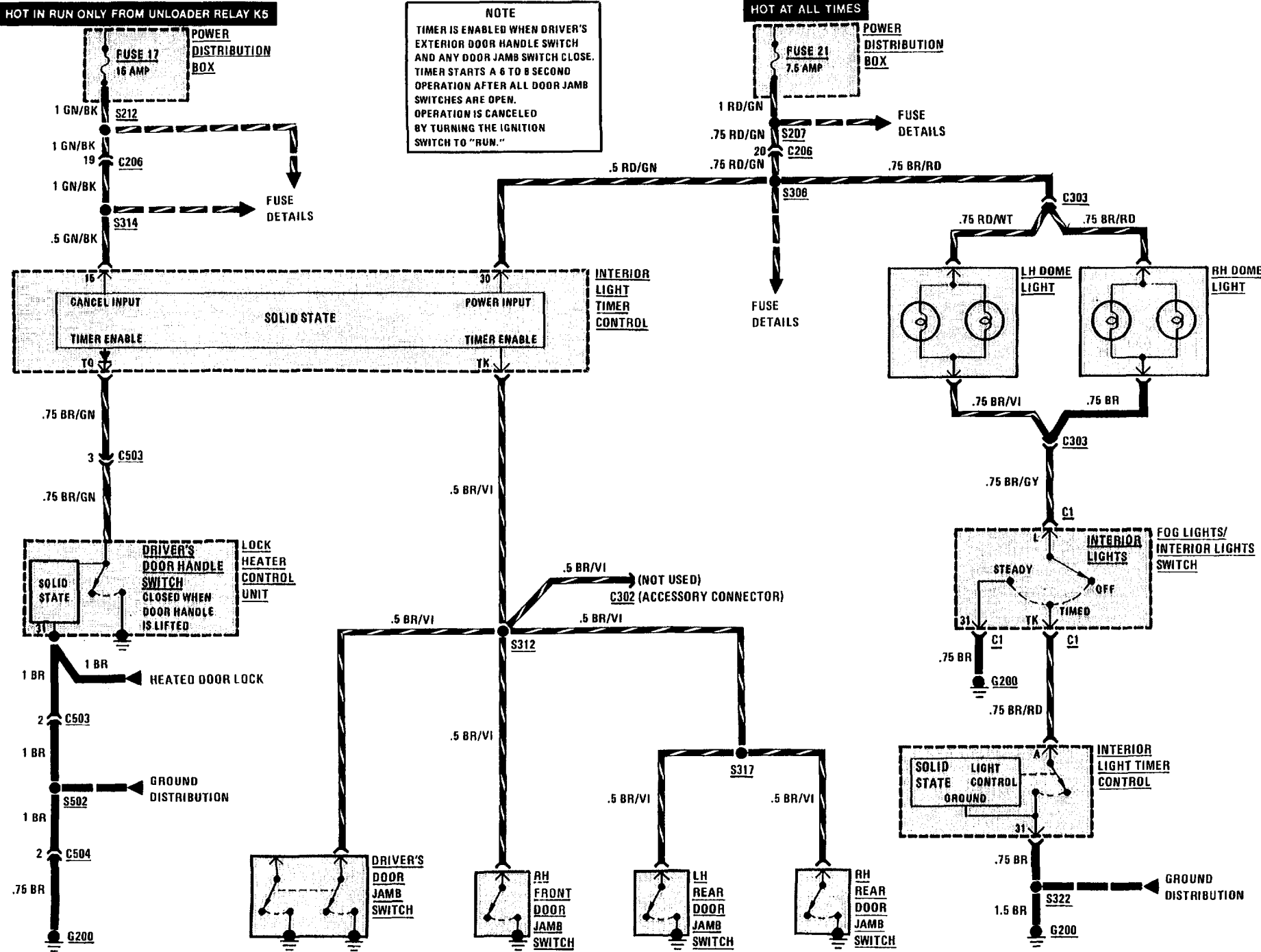

**NOTE**  
 TIMER IS ENABLED WHEN DRIVER'S EXTERIOR DOOR HANDLE SWITCH AND ANY DOOR JAMB SWITCH CLOSE. TIMER STARTS A 6 TO 8 SECOND OPERATION AFTER ALL DOOR JAMB SWITCHES ARE OPEN. OPERATION IS CANCELED BY TURNING THE IGNITION SWITCH TO "RUN."

CENTER CONSOLE LIGHTS

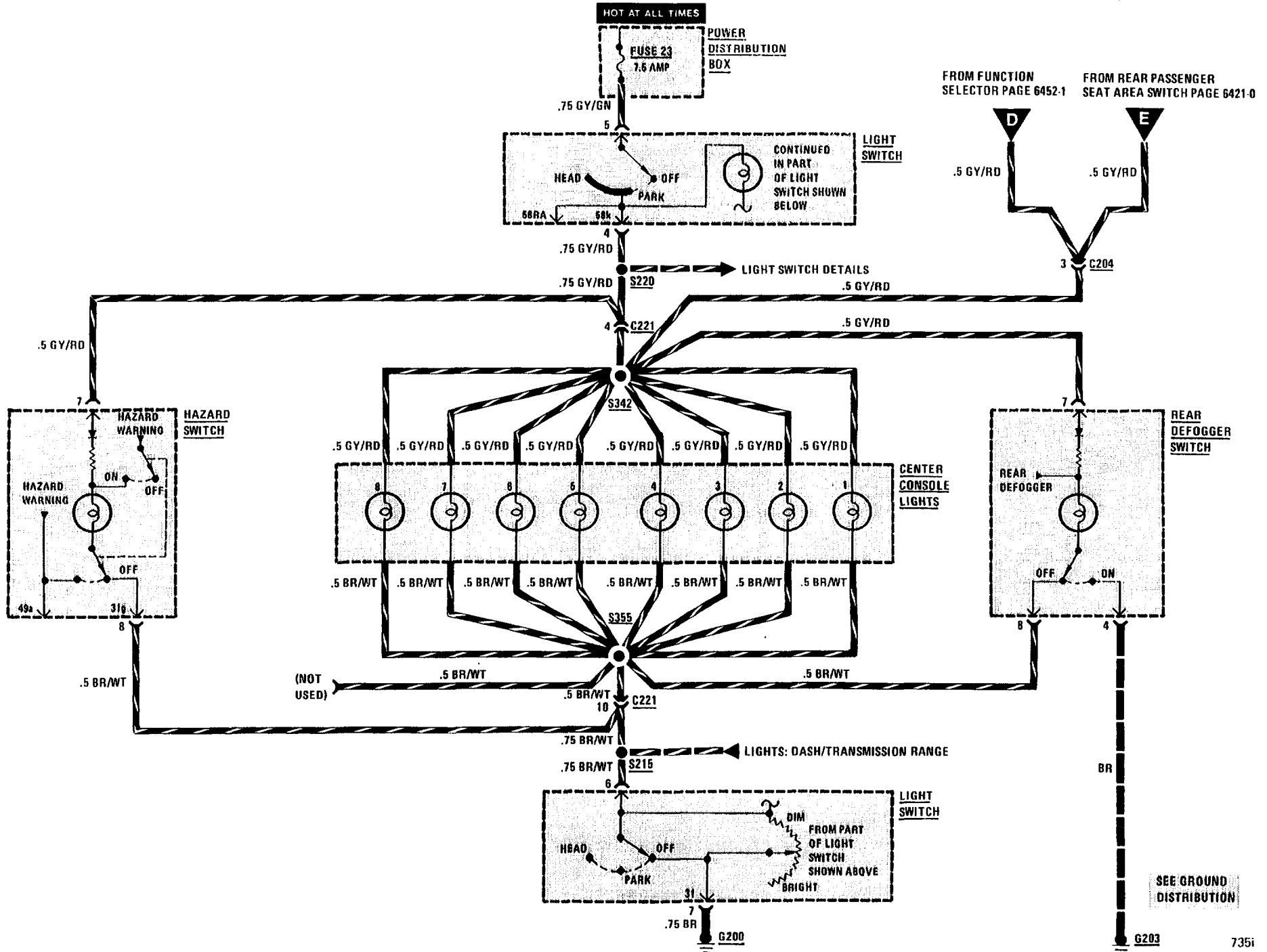

TEMPERATURE CONTROL LOOP EARLY PRODUCTION

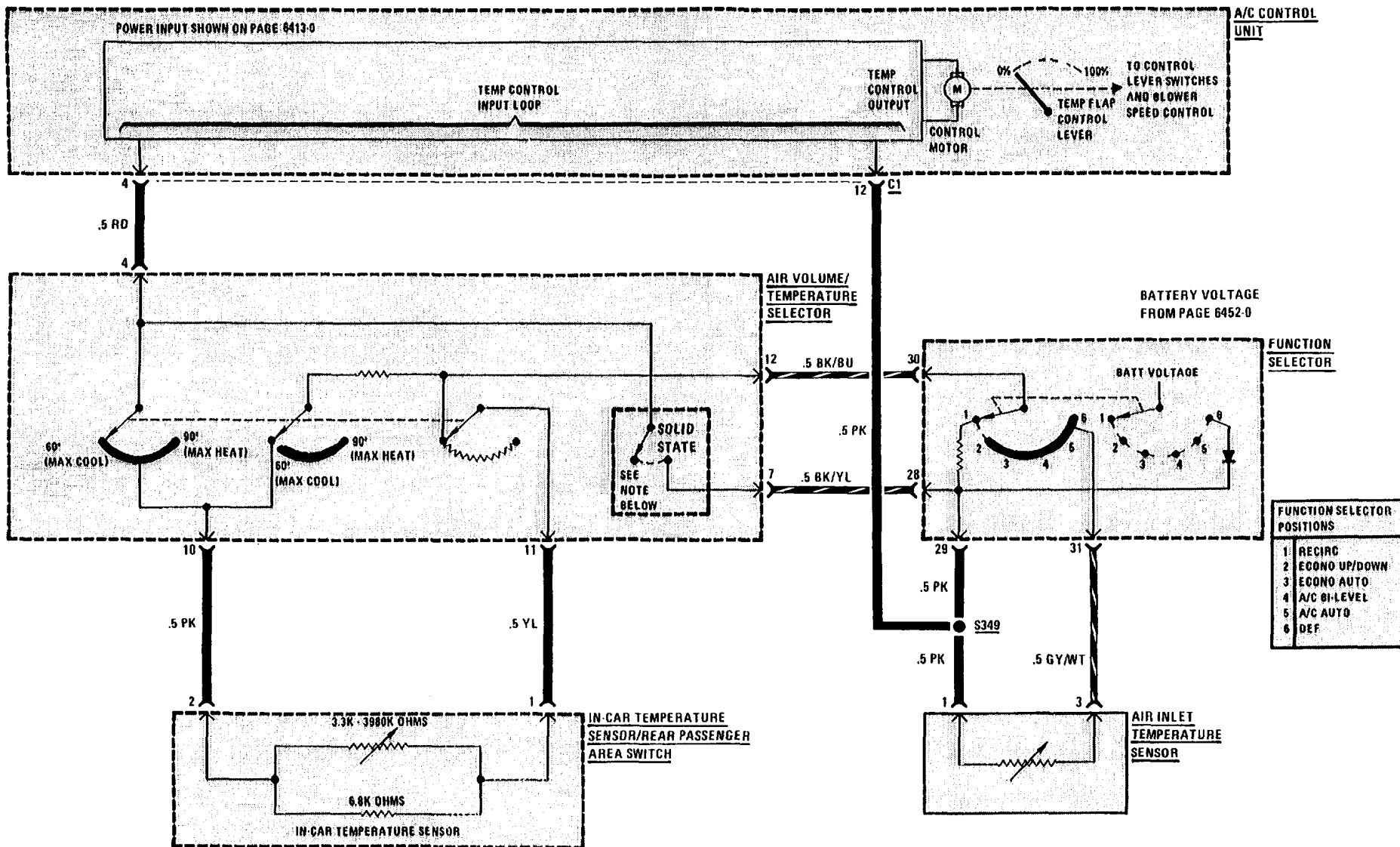

NOTE: SOLID STATE SWITCH IS CLOSED WHEN FUNCTION SELECT IS IN RECIRC ① OR DEF ⑥



TEMPERATURE CONTROL LOOP LATE PRODUCTION

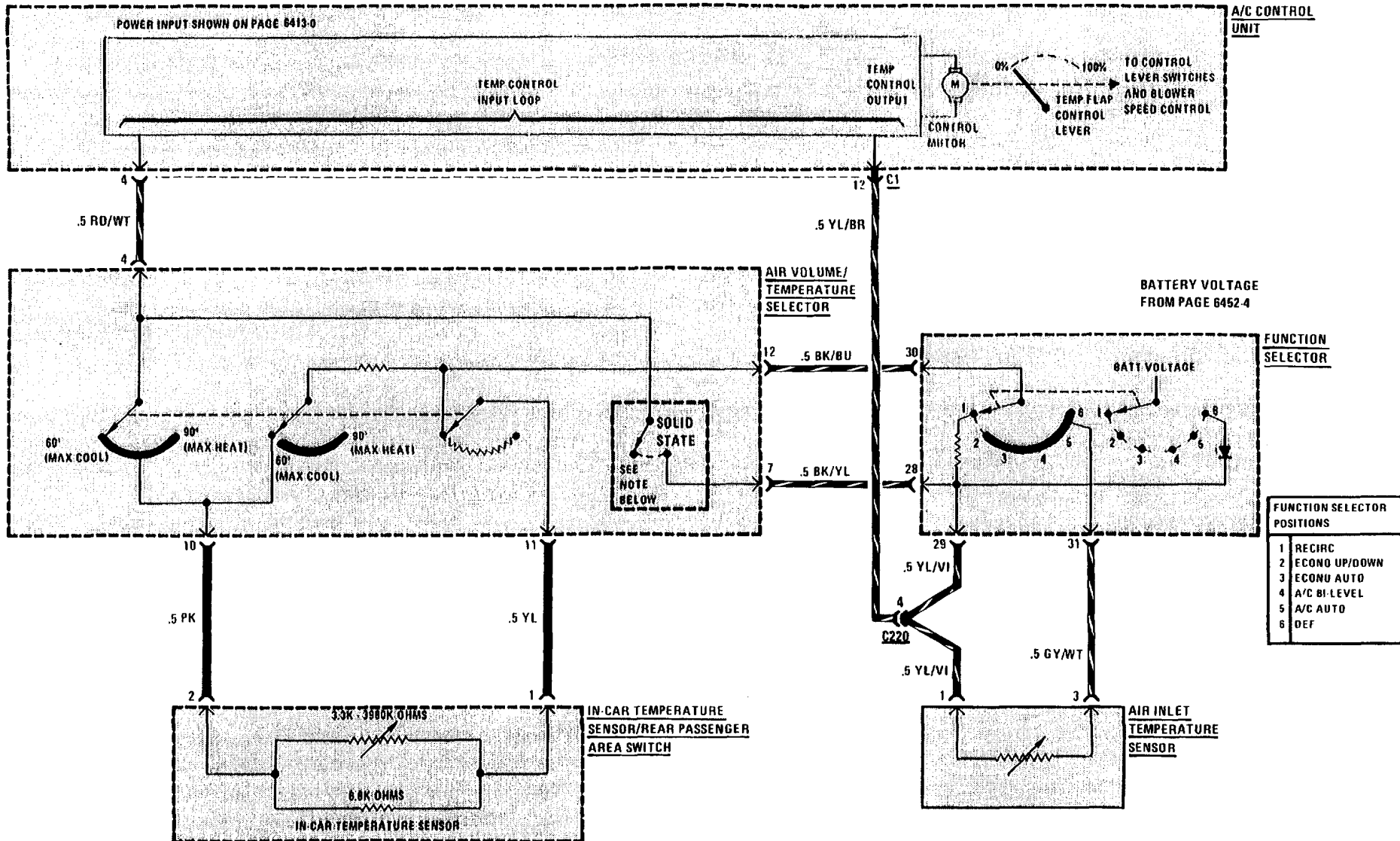

NOTE: SOLID STATE SWITCH IS CLOSED WHEN FUNCTION SELECT IS IN RECIRC ① OR DEF ⑥



**AUTOMATIC HEATER-AIR CONDITIONER (BLOWER CONTROLS) EARLY PRODUCTION**

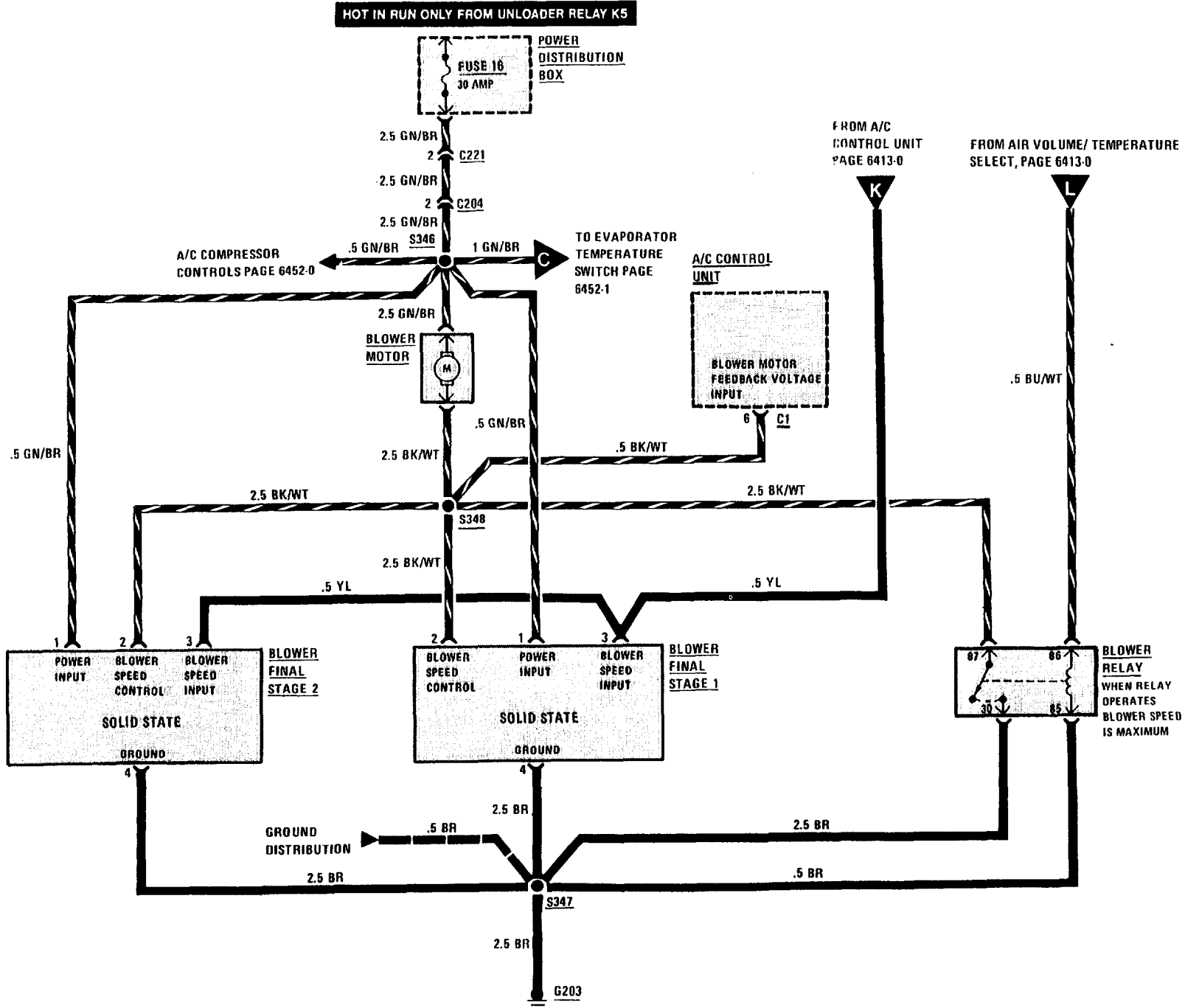





REAR PASSENGER AREA SOLENOID VALVE CONTROL EARLY PRODUCTION

BATTERY VOLTAGE  
FROM PAGE 6452-1

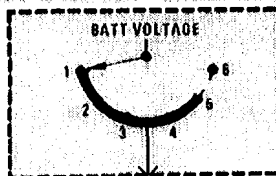

FUNCTION  
SELECTOR

FUNCTION SELECTOR  
POSITIONS

1	RECIRC
2	ECONO UP/DOWN
3	ECONO AUTO
4	A/C B LEVEL
5	A/C AUTO
6	DEF



AIR VOLUME/  
TEMPERATURE  
SELECT

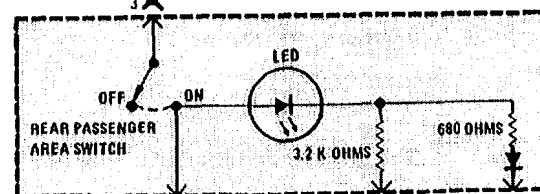

IN-CAR TEMPERATURE  
SENSOR/REAR PASSENGER  
AREA SWITCH

TO C204,  
PAGE 6330-1  
DIMS LED WHEN  
LIGHT SWITCH IS  
IN HEAD OR PARK

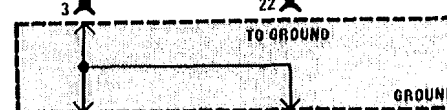

AIR VOLUME/  
TEMPERATURE  
SELECTOR

REAR PASSENGER  
AREA SOLENOID  
VALVE

BLACK HOSE  
(MUI)

A/C  
COMPRESSOR  
CONTROL

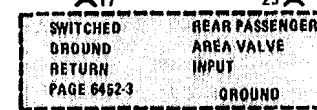

FUNCTION  
SELECTOR

GROUND  
DISTRIBUTION

G203

FRESH AIR AND RECIRCULATION SOLENOID VALVE CONTROLS EARLY PRODUCTION

BATTERY VOLTAGE FROM PAGE 6452-0

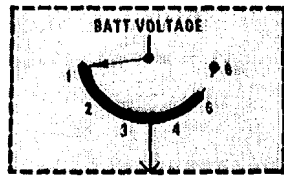

FUNCTION SELECTOR

FUNCTION SELECTOR POSITIONS	
1	RECIRC
2	ECOND UP/DOWN
3	ECOND AUTO
4	A/C BI-LEVEL
5	A/C AUTO
6	DEF

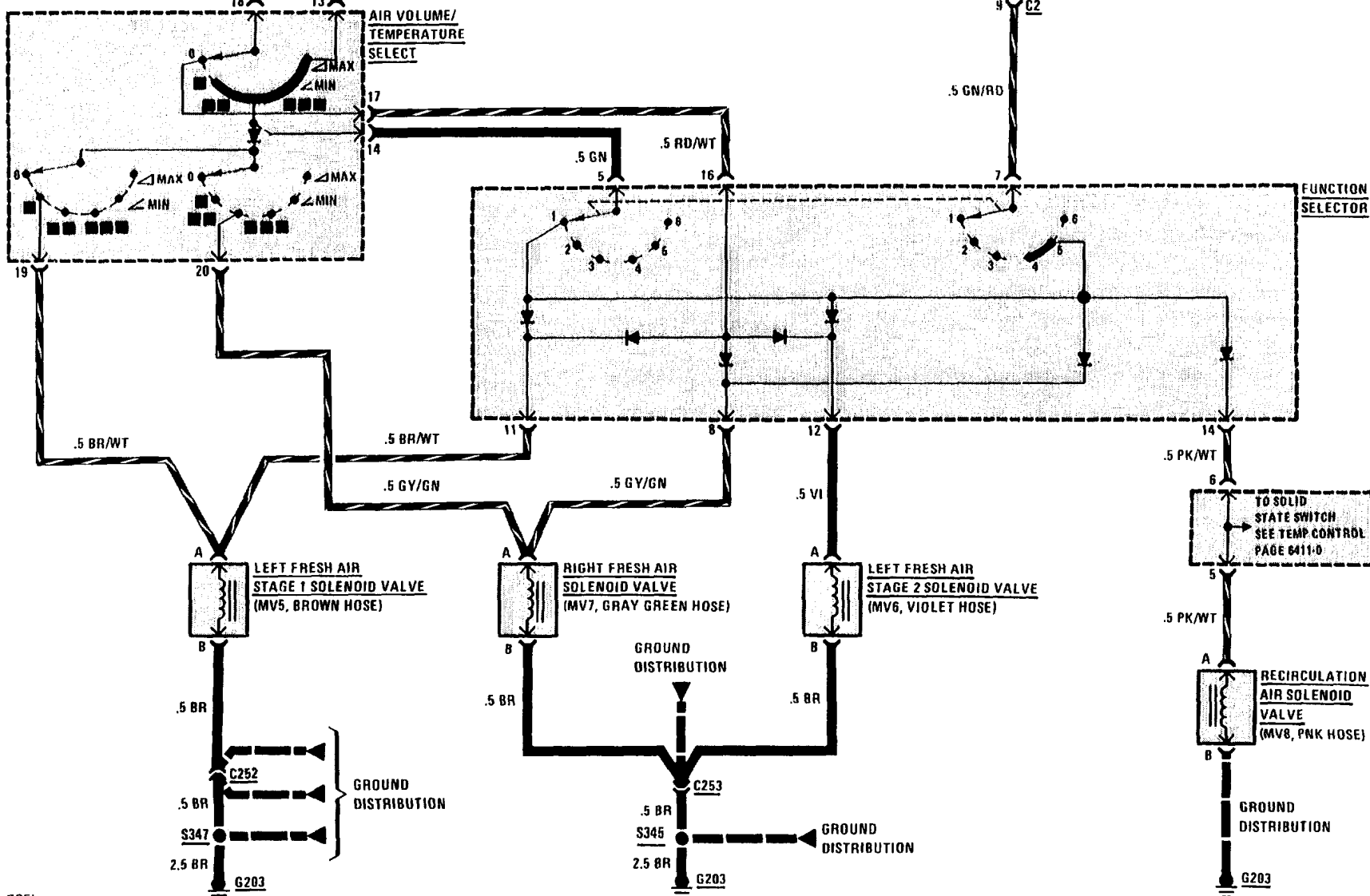
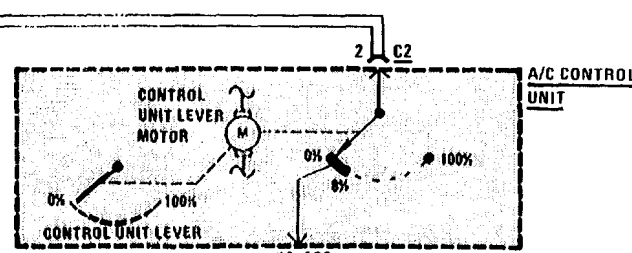

LEFT FRESH AIR STAGE 1 SOLENOID VALVE (MV5, BROWN HOSE)

RIGHT FRESH AIR SOLENOID VALVE (MV7, GRAY GREEN HOSE)

LEFT FRESH AIR STAGE 2 SOLENOID VALVE (MV6, VIOLET HOSE)

TO SOLID STATE SWITCH SEE TEMP CONTROL PAGE 6411-0

RECIRCULATION AIR SOLENOID VALVE (MV8, PNK HOSE)

DEFROST SOLENOID VALVE CONTROL EARLY PRODUCTION

FUNCTION SELECTOR POSITIONS
1 RECIRC
2 ECONO UP/DOWN
3 ECONO AUTO
4 A/C 81 LEVEL
5 A/C AUTO
6 DEF

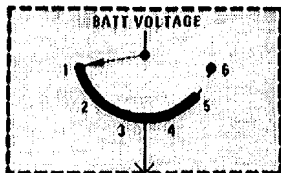

FUNCTION SELECTOR

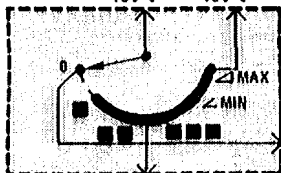

AIR VOLUME/TEMPERATURE SELECT

BATTERY VOLTAGE FROM PAGE 6452.0

CONTINUED ON THIS PAGE

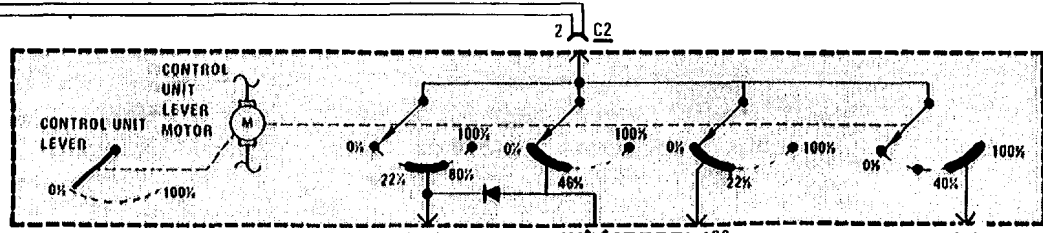

A/C CONTROL UNIT

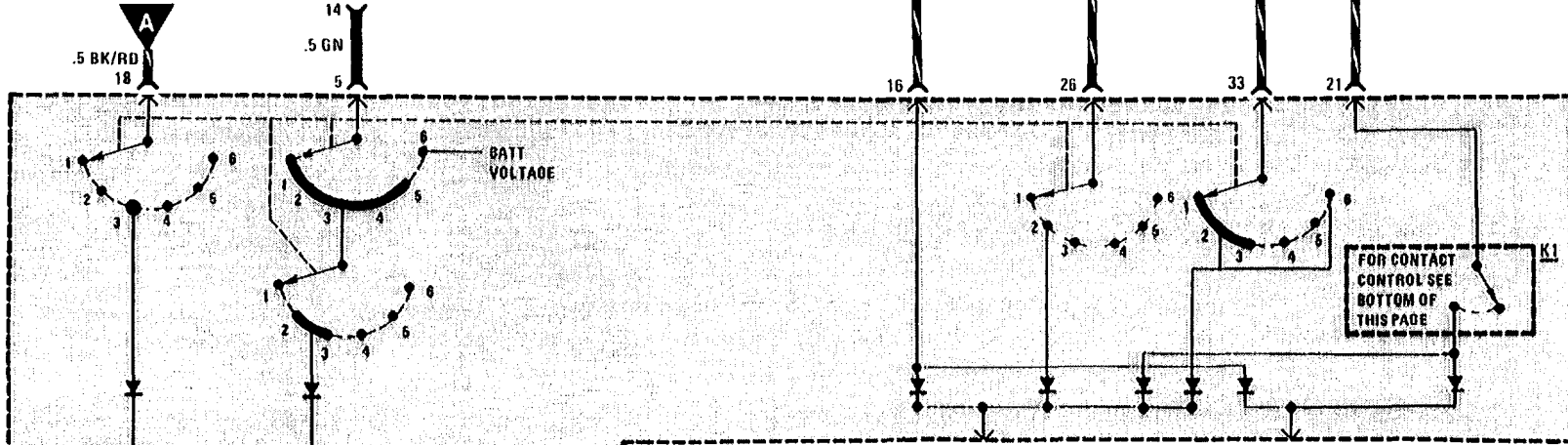

FUNCTION SELECTOR

.5 BK/RD 18

.5 GN 5

16

.5 OR/WT 3

.5 VI/WT 4

.5 GN/BU 5

.5 BK/RD A

CONTINUED ON THIS PAGE

1 2 3 4 5 6

1 2 3 4 5 6

BATT VOLTAGE

1 2 3 4 5 6

1 2 3 4 5 6

FOR CONTACT CONTROL SEE BOTTOM OF THIS PAGE

K1

FOR DETAILS SEE SWITCHED GROUND DETAILS PAGE 6452.3

FOR CONTACT WIRING SEE TOP OF THIS PAGE

DEFROST STAGE 1 SOLENOID VALVE (MV11, LT BLUE HOSE)

DEFROST STAGE 2 SOLENOID VALVE (MV9, WHITE HOSE)

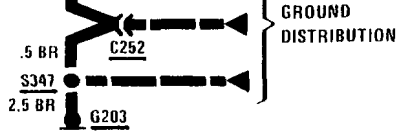
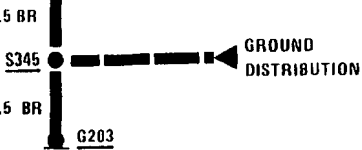



WATER VALVE SOLENOID CONTROL EARLY PRODUCTION

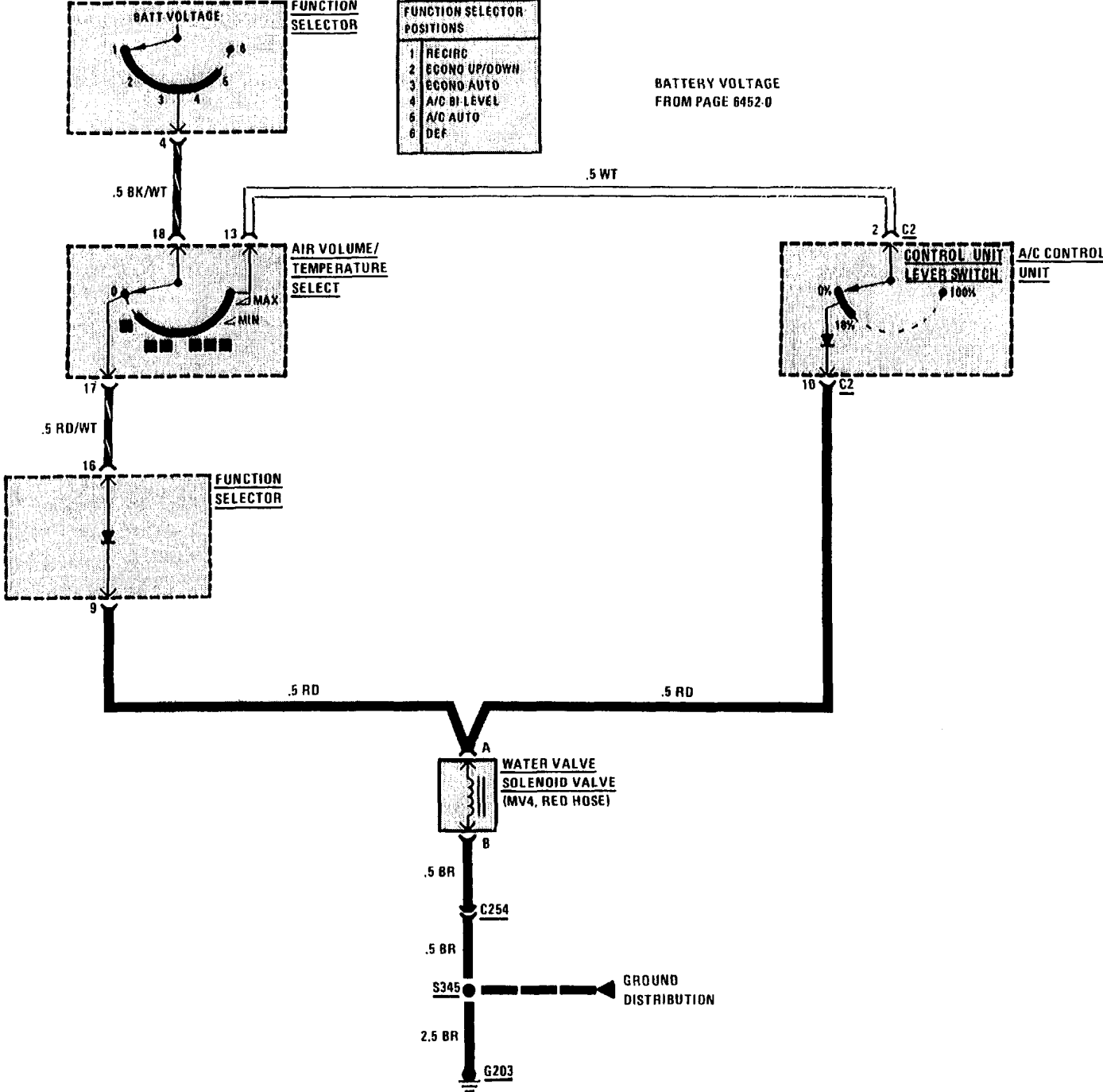

FUNCTION SELECTOR POSITIONS	
1	RECIRC
2	ECONG UP/DOWN
3	ECONG AUTO
4	A/C BI-LEVEL
5	A/C AUTO
6	DEF

BATTERY VOLTAGE FROM PAGE 6452-0

**VENT STAGE AND FOOTWELL SOLENOID VALVE CONTROLS EARLY PRODUCTION**

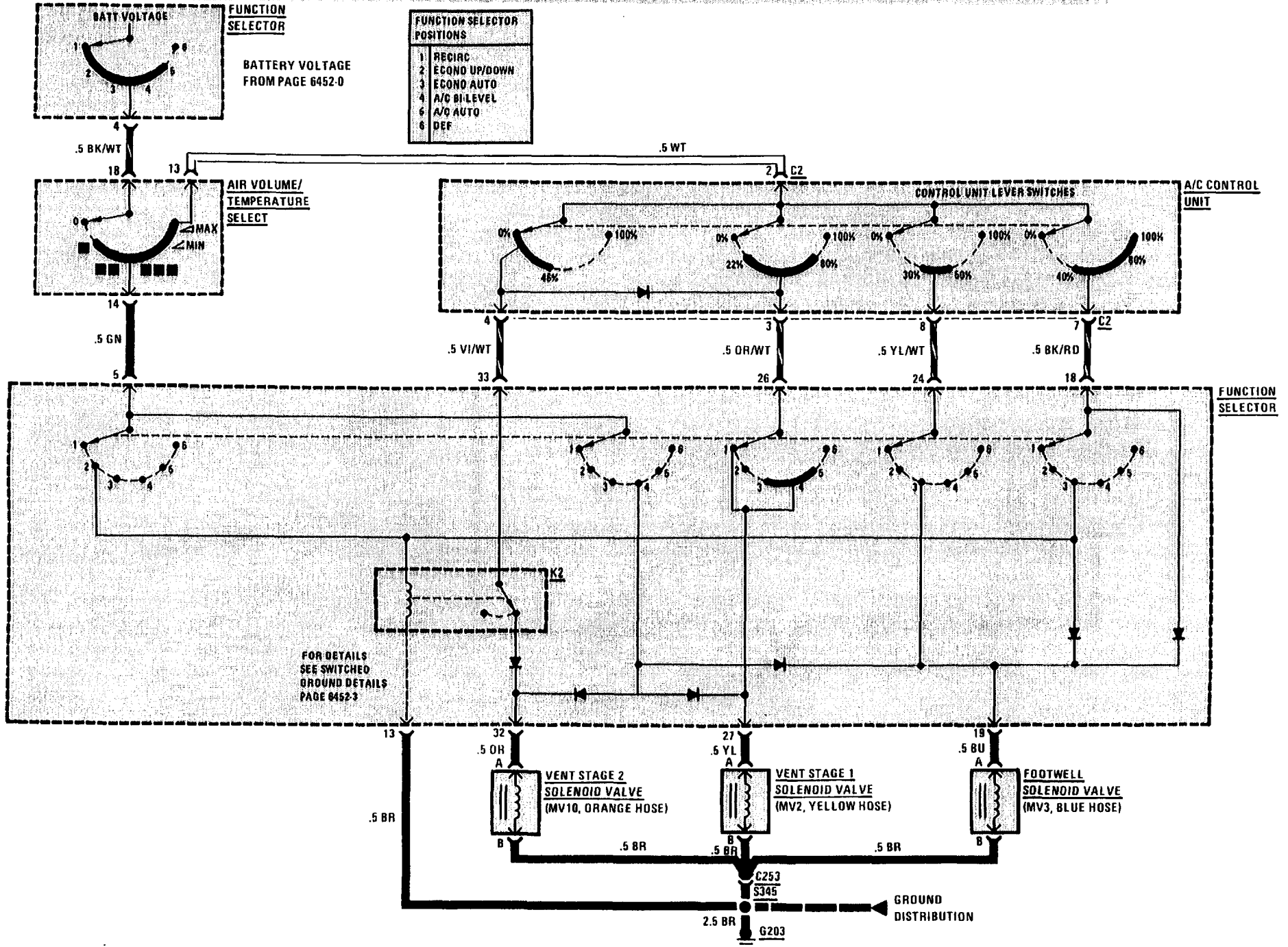

REAR PASSENGER AREA SOLENOID VALVE CONTROL  
LATE PRODUCTION

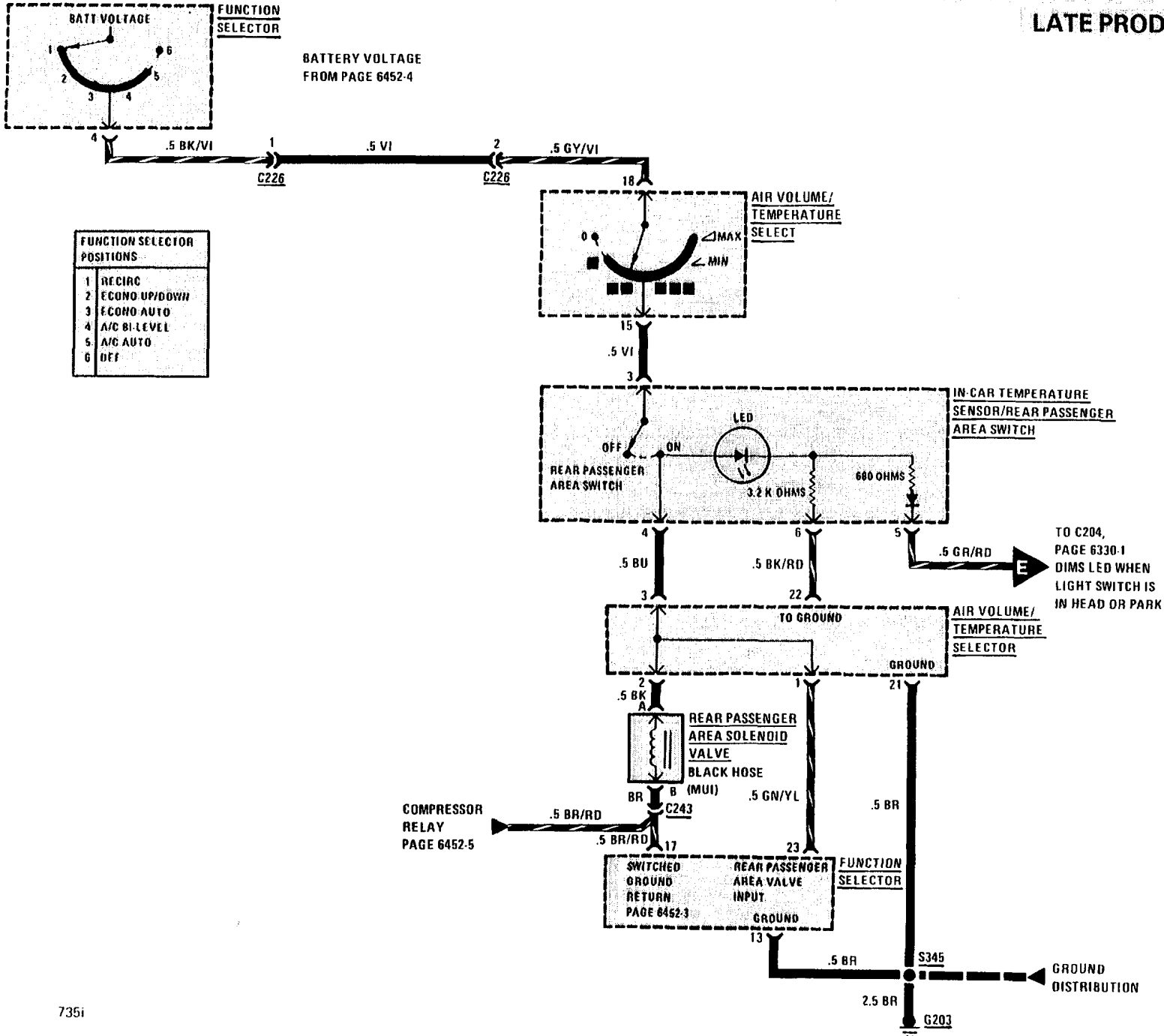

FRESH AIR AND RECIRCULATION SOLENOID VALVE CONTROLS LATE PRODUCTION

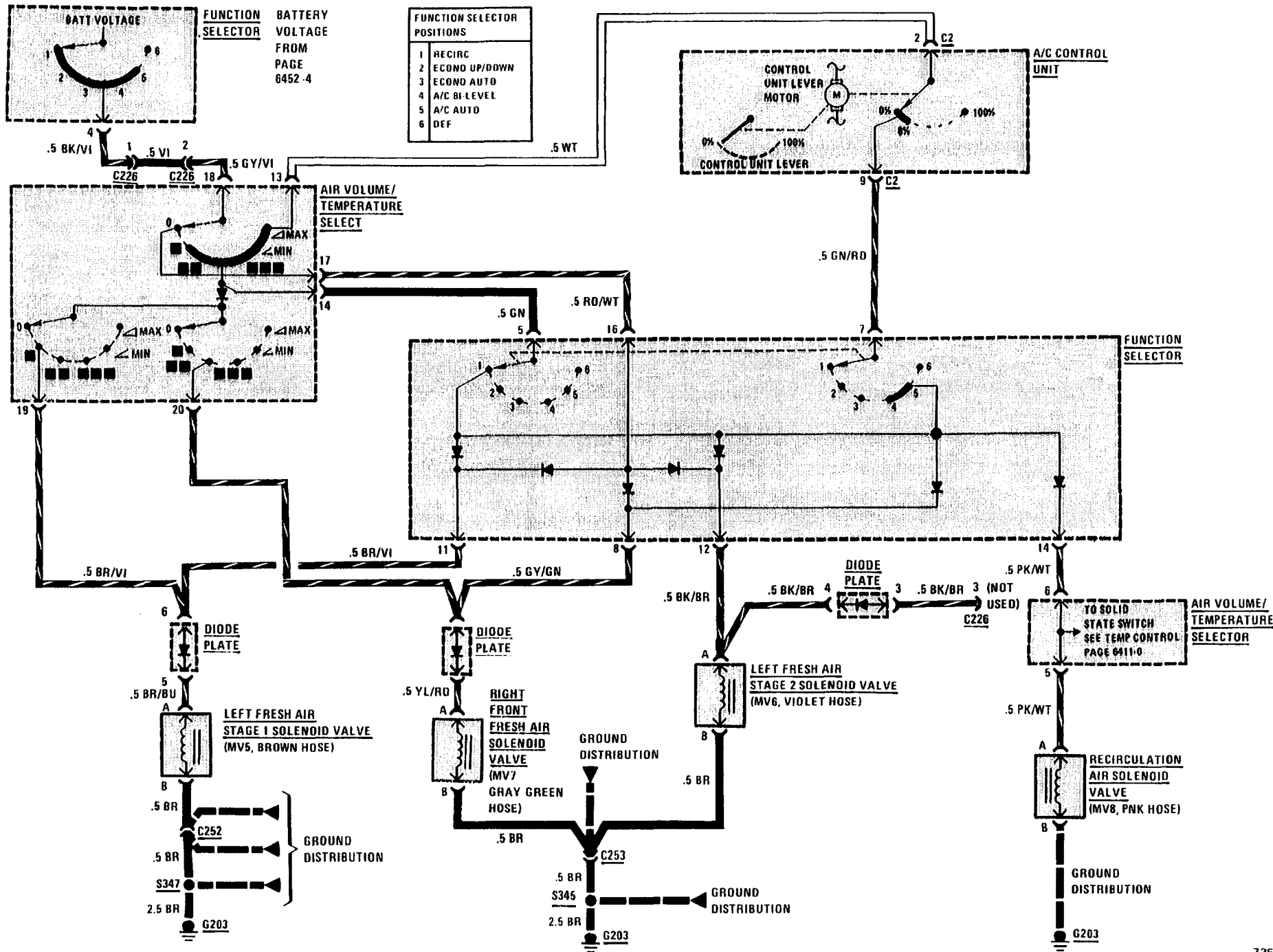

DEFROST SOLENOID VALVE CONTROL LATE PRODUCTION

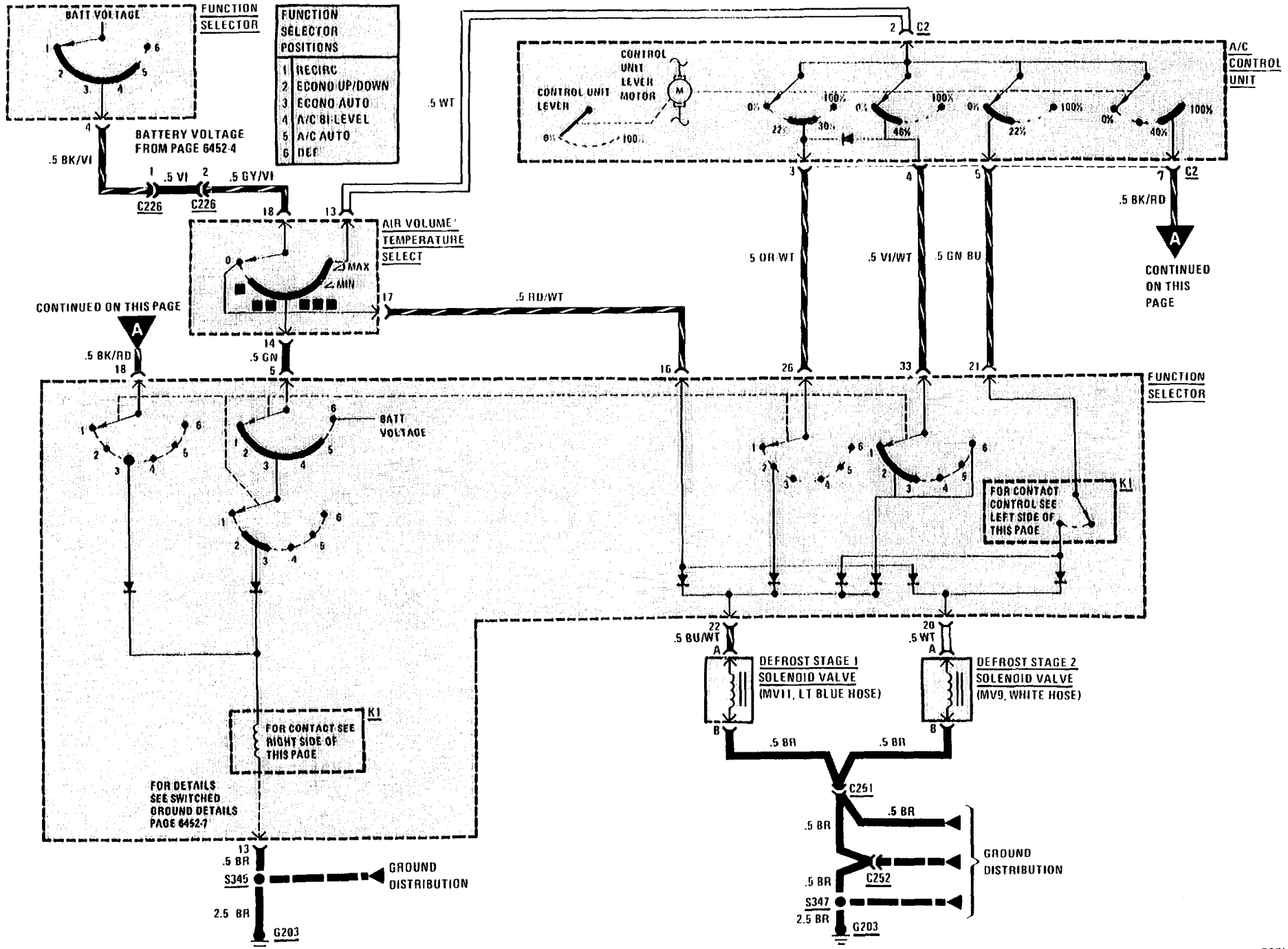

# 6421-8 A/C AIR DELIVERY CONTROL

## WATER VALVE SOLENOID CONTROL LATE PRODUCTION

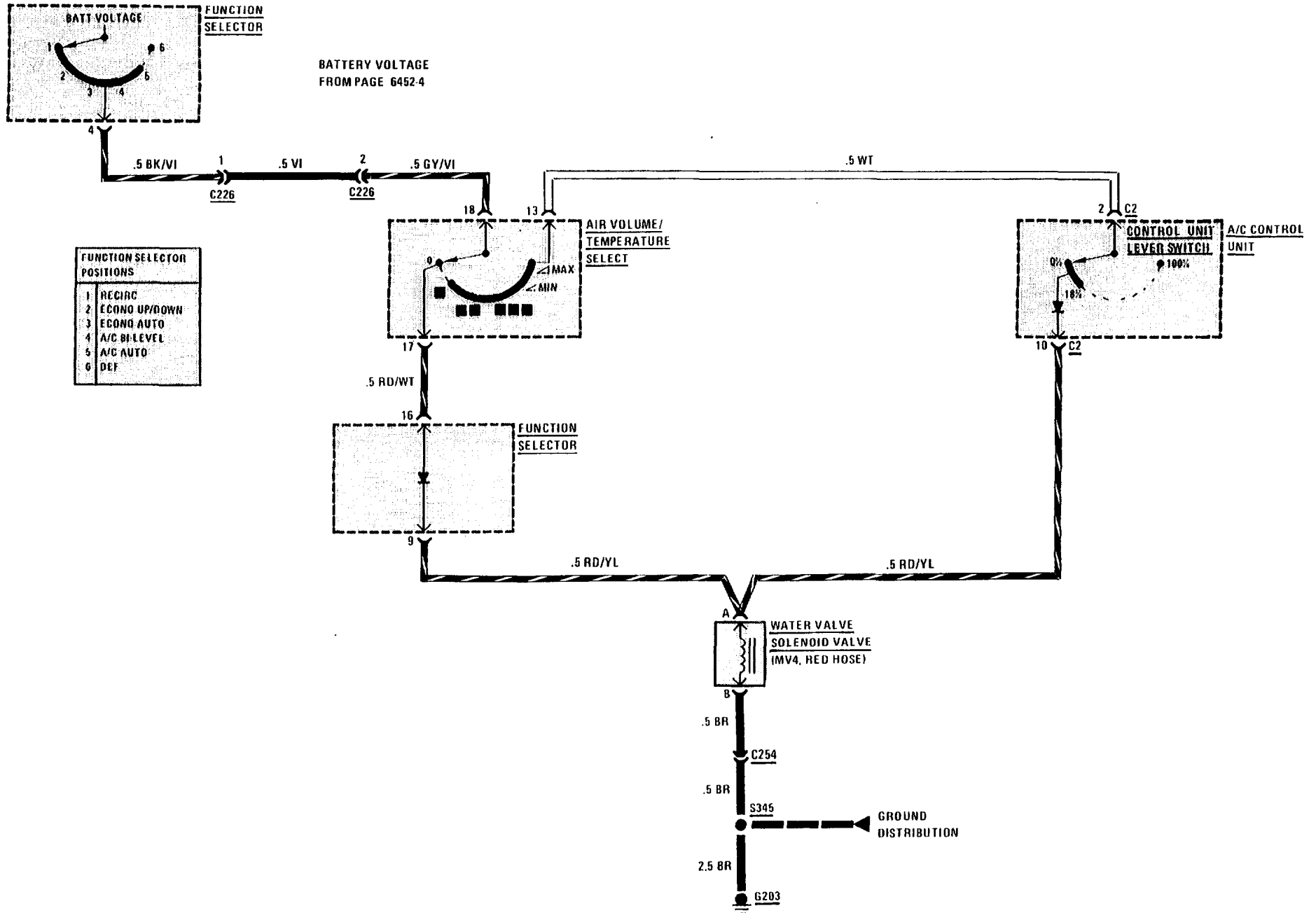

VENT STAGE AND FOOTWELL SOLENOID VALVE CONTROLS LATE PRODUCTION

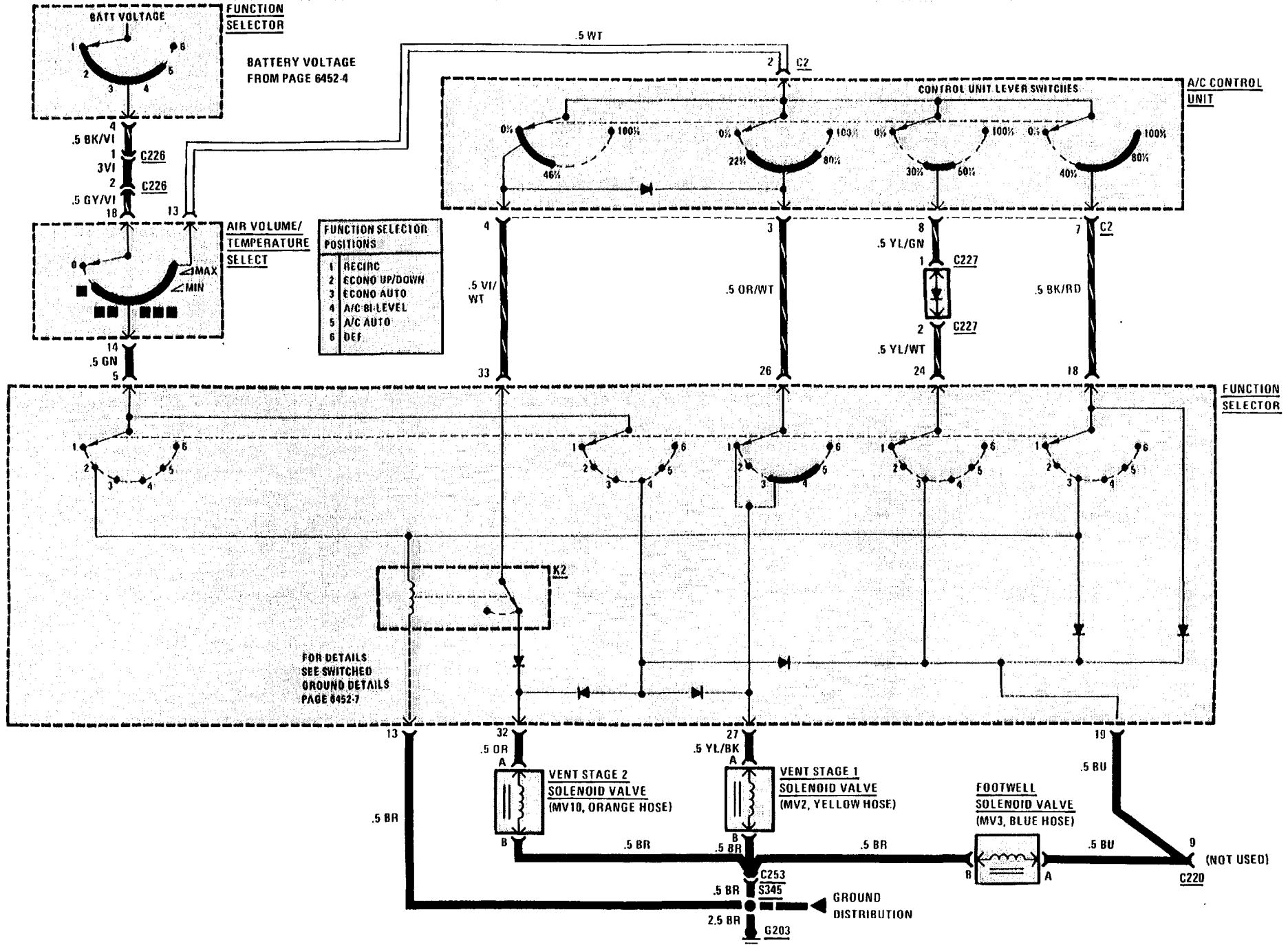

# 6452-0 A/C COMPRESSOR CONTROL

## AUTOMATIC HEATER-AIR CONDITIONER (COMPRESSOR CONTROL) EARLY PRODUCTION

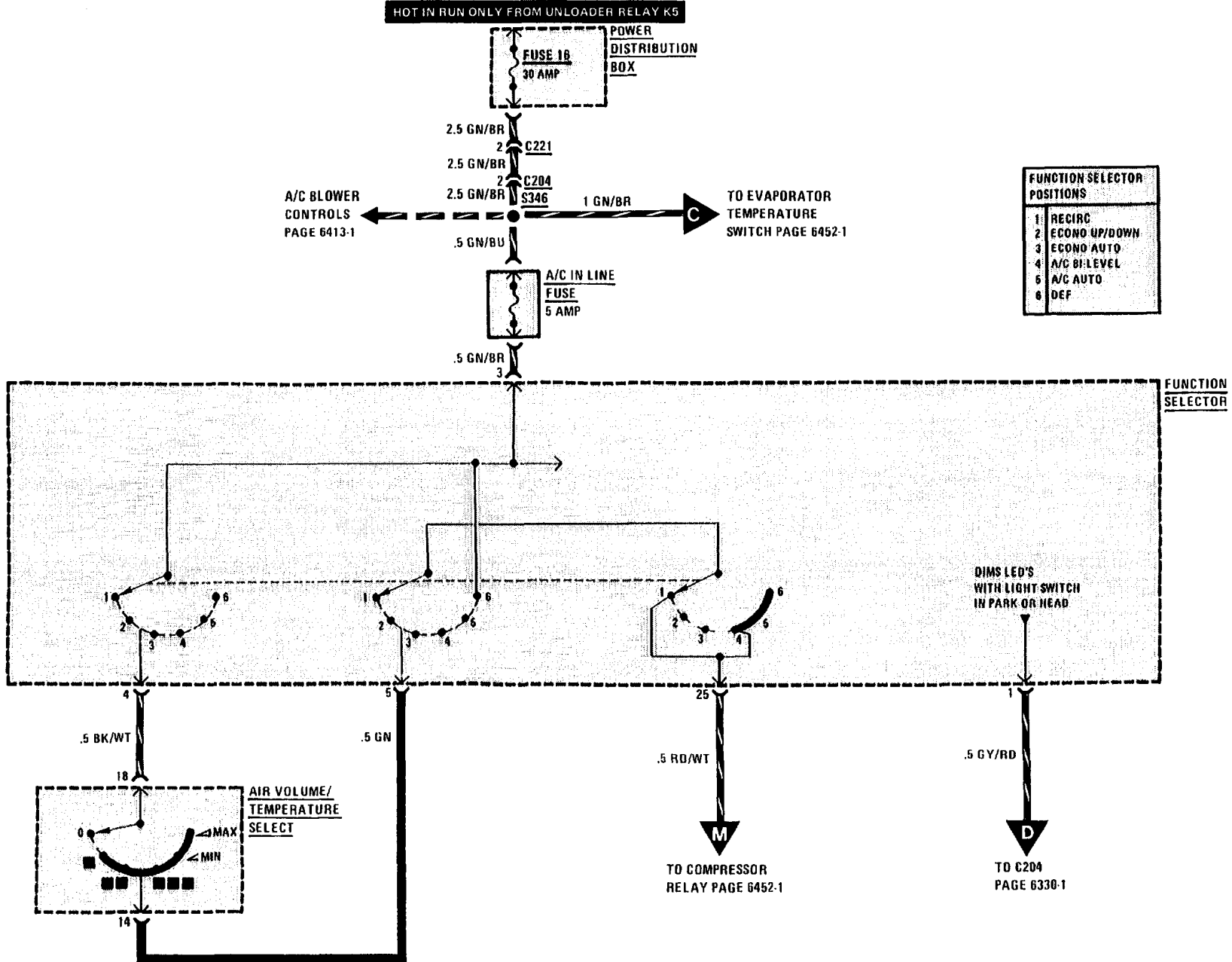





# 6452-2 A/C COMPRESSOR CONTROL

## AUTOMATIC HEATER-AIR CONDITIONER (COLD START INHIBIT-SWITCH GROUND)

EARLY PRODUCTION

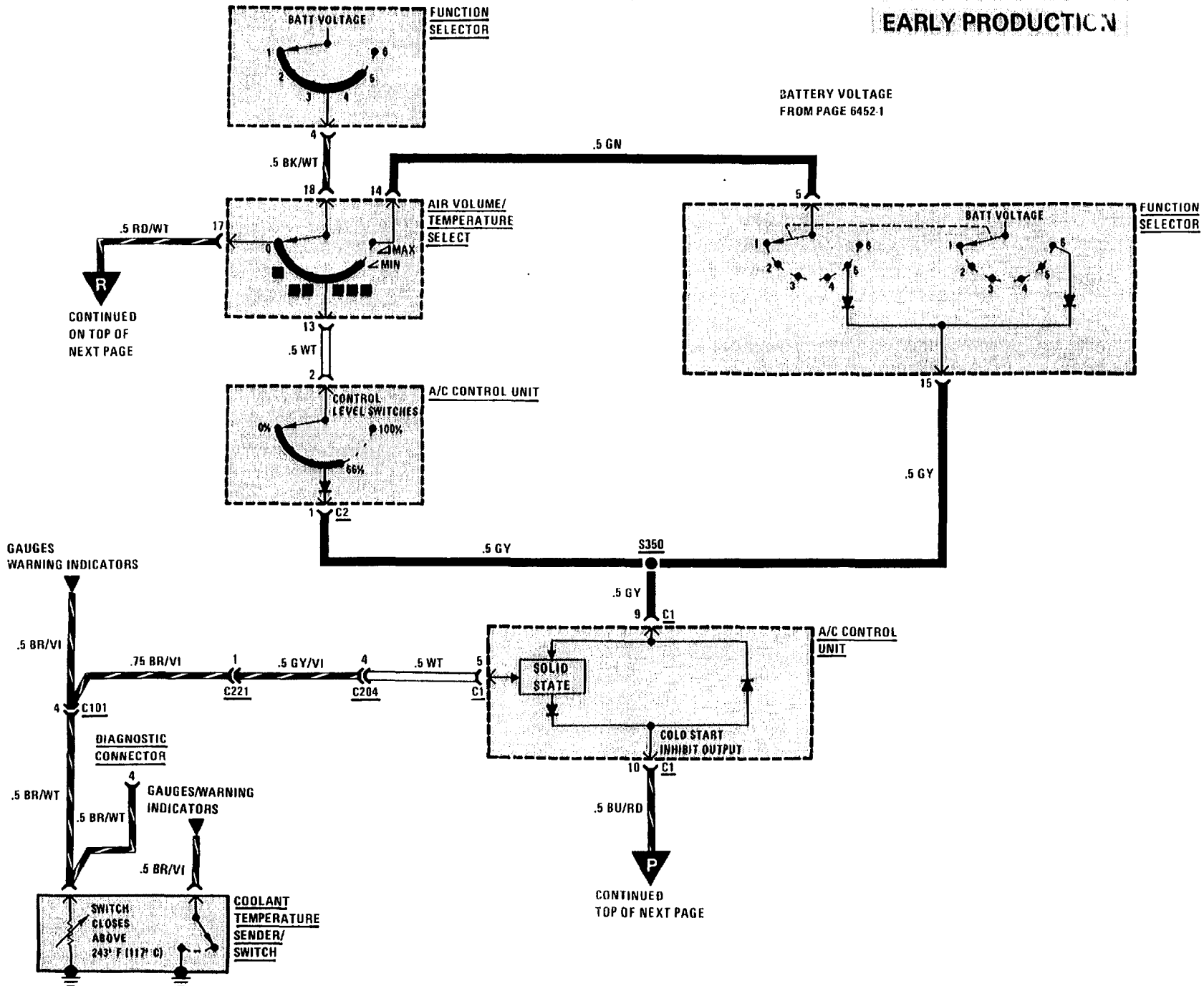

AUTOMATIC HEATER-AIR CONDITIONER (COLD START INHIBIT-SWITCH GROUND) EARLY PRODUCTION

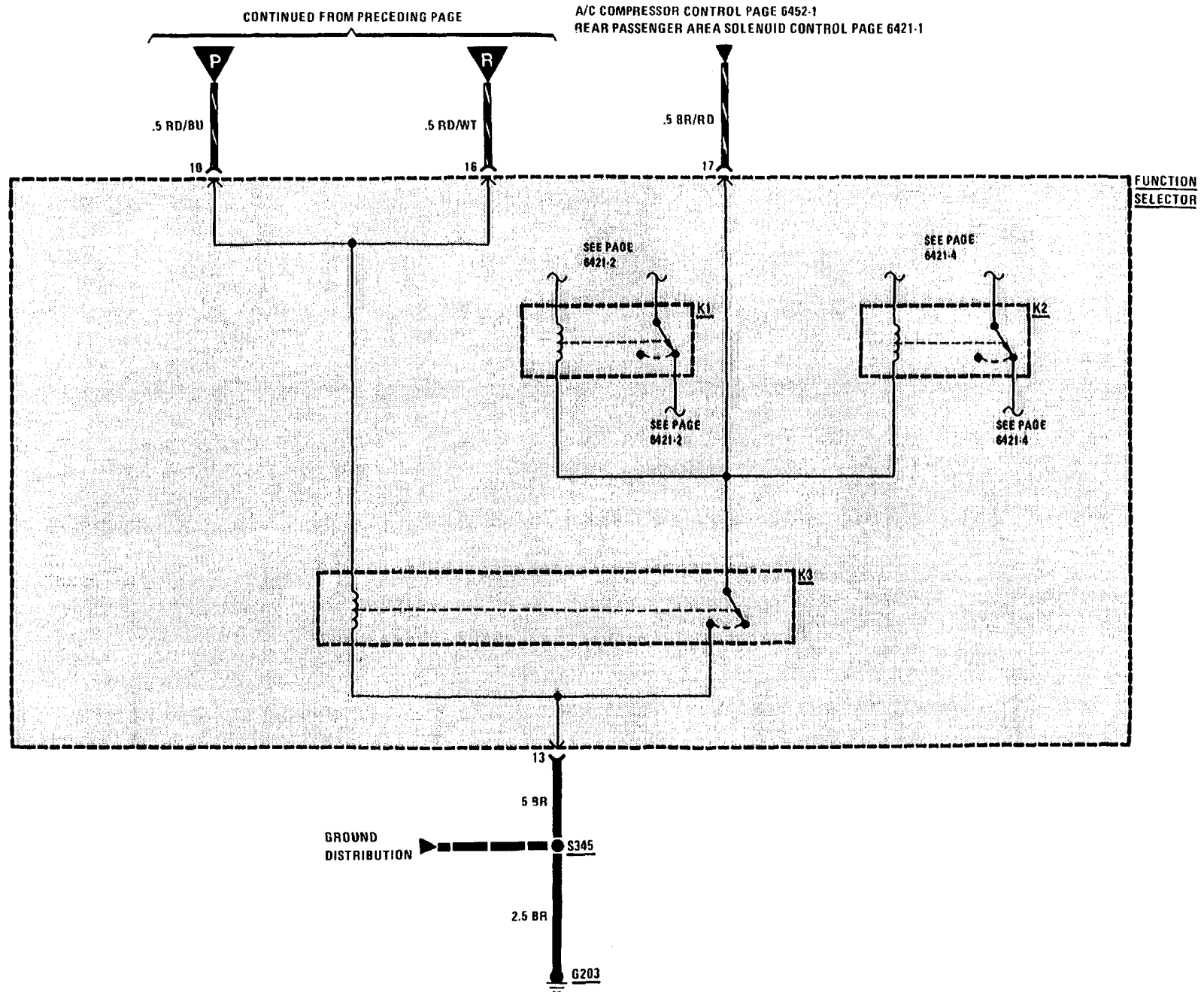

AUTOMATIC HEATER-AIR CONDITIONER (COMPRESSOR CONTROL) LATE PRODUCTION

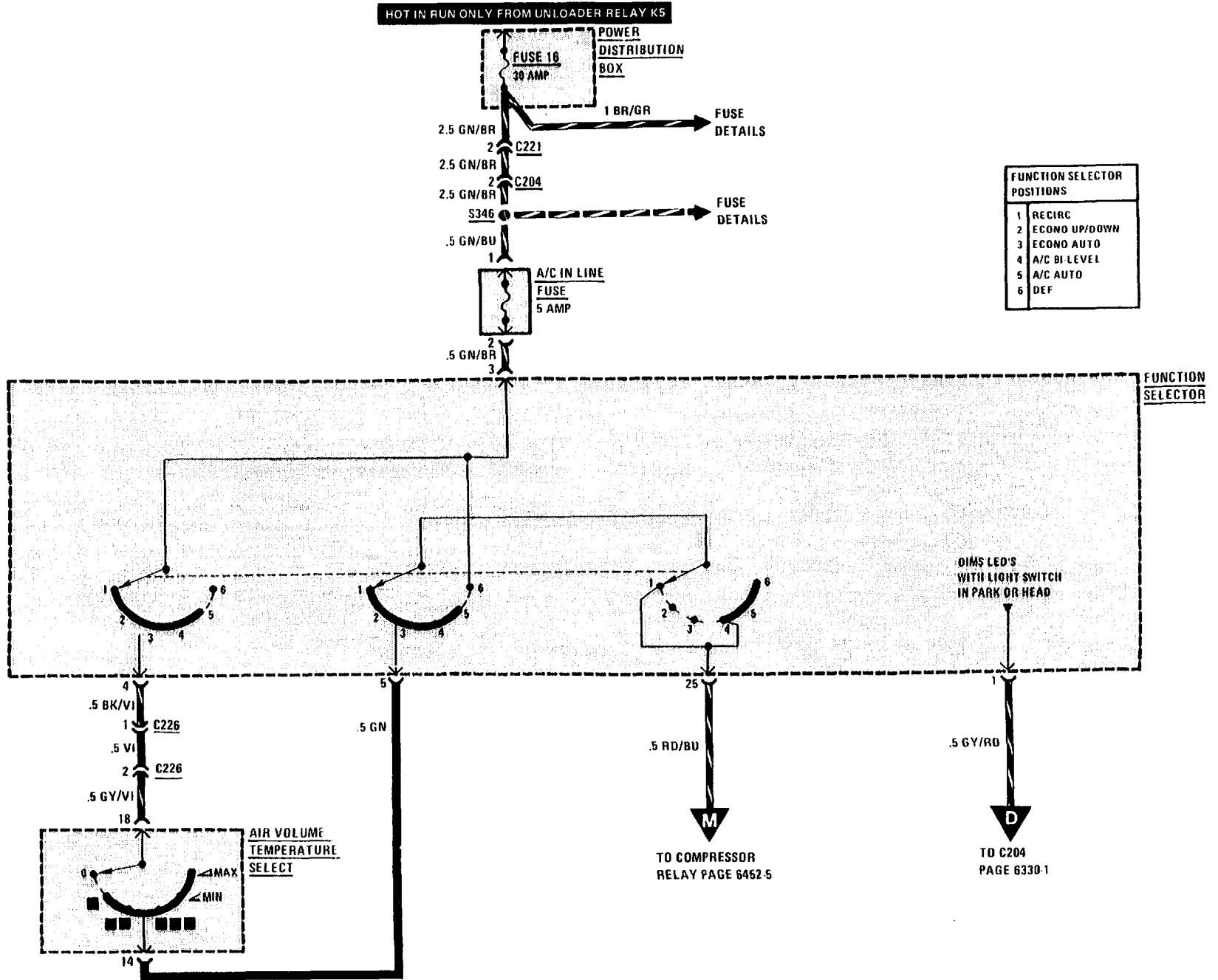

**AUTOMATIC HEATER-AIR CONDITIONER (COMPRESSOR CONTROL) LATE PRODUCTION**

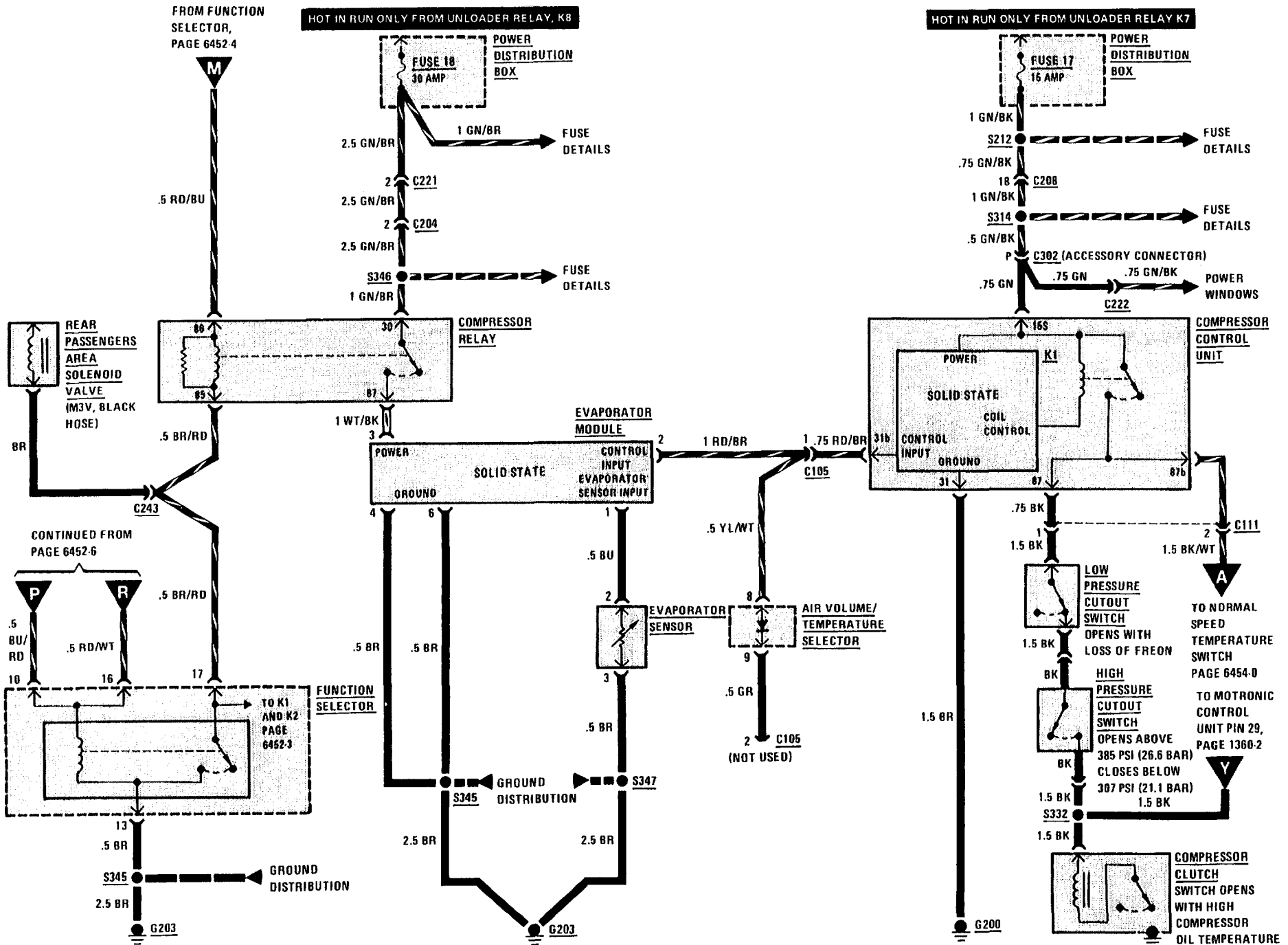



AUTOMATIC HEATER-AIR CONDITIONER (COLD START INHIBIT-SWITCH GROUND) LATE PRODUCTION

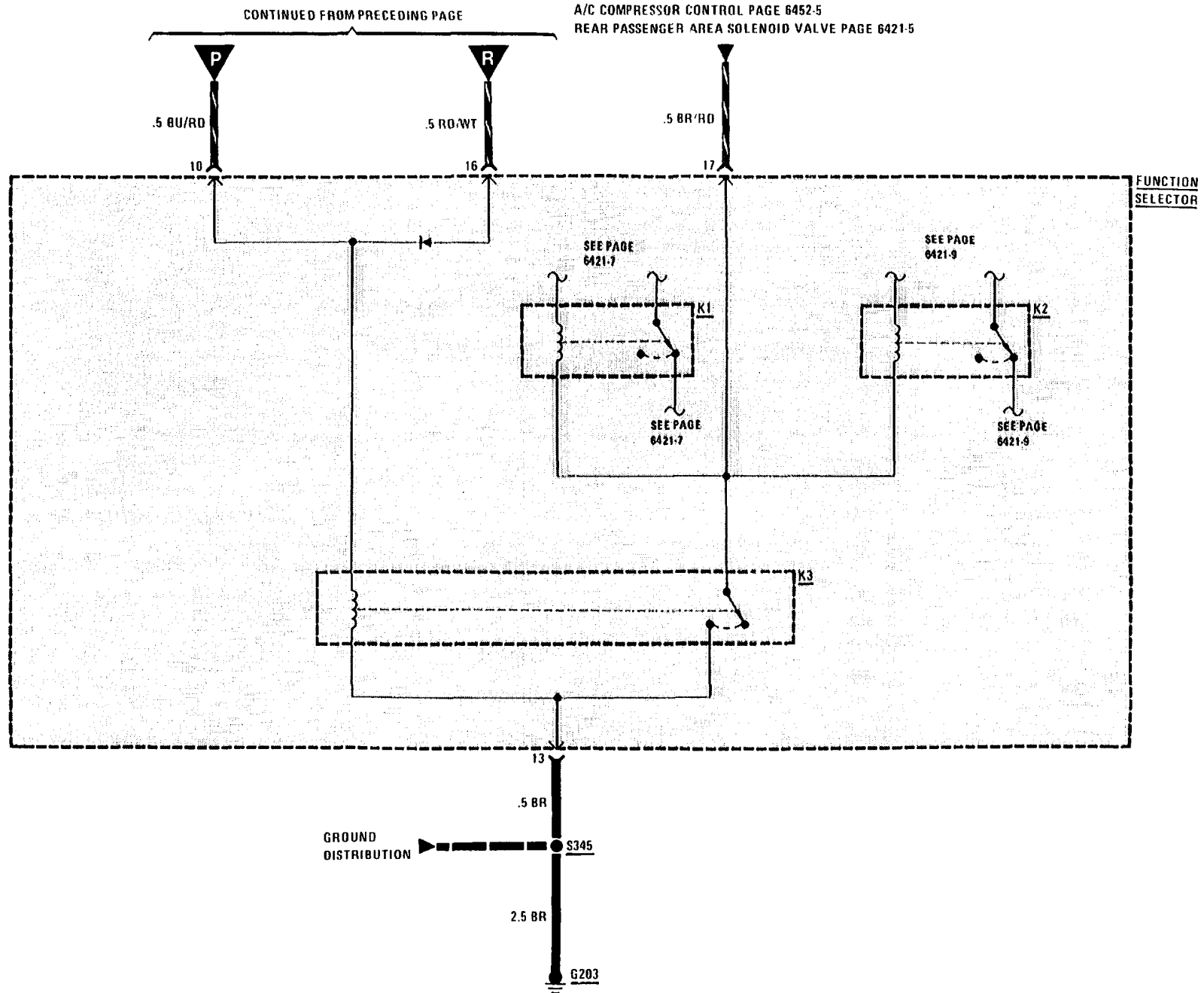

AUXILIARY FAN/VACUUM PUMP

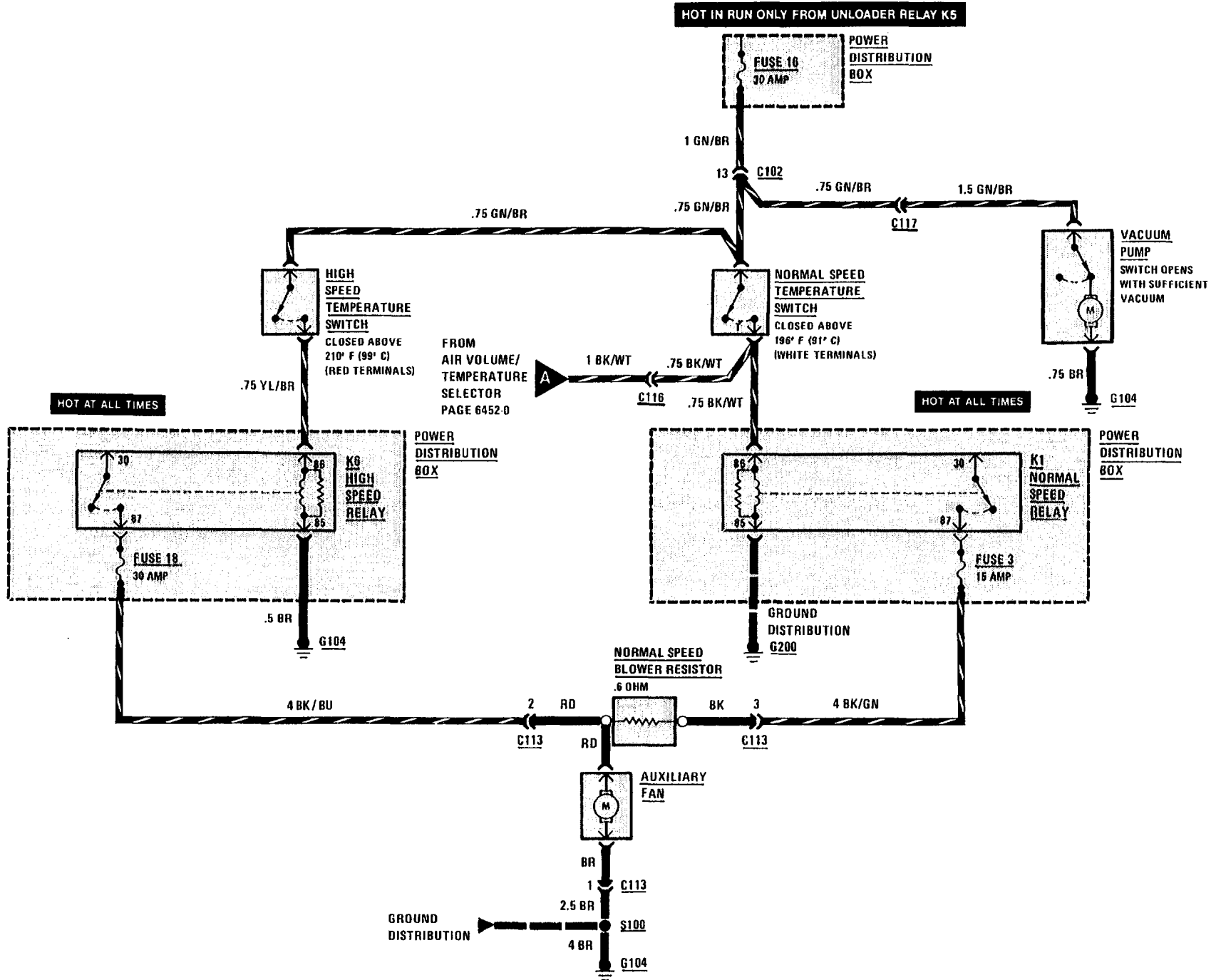



# 6500-0 RADIO/ANTENNA

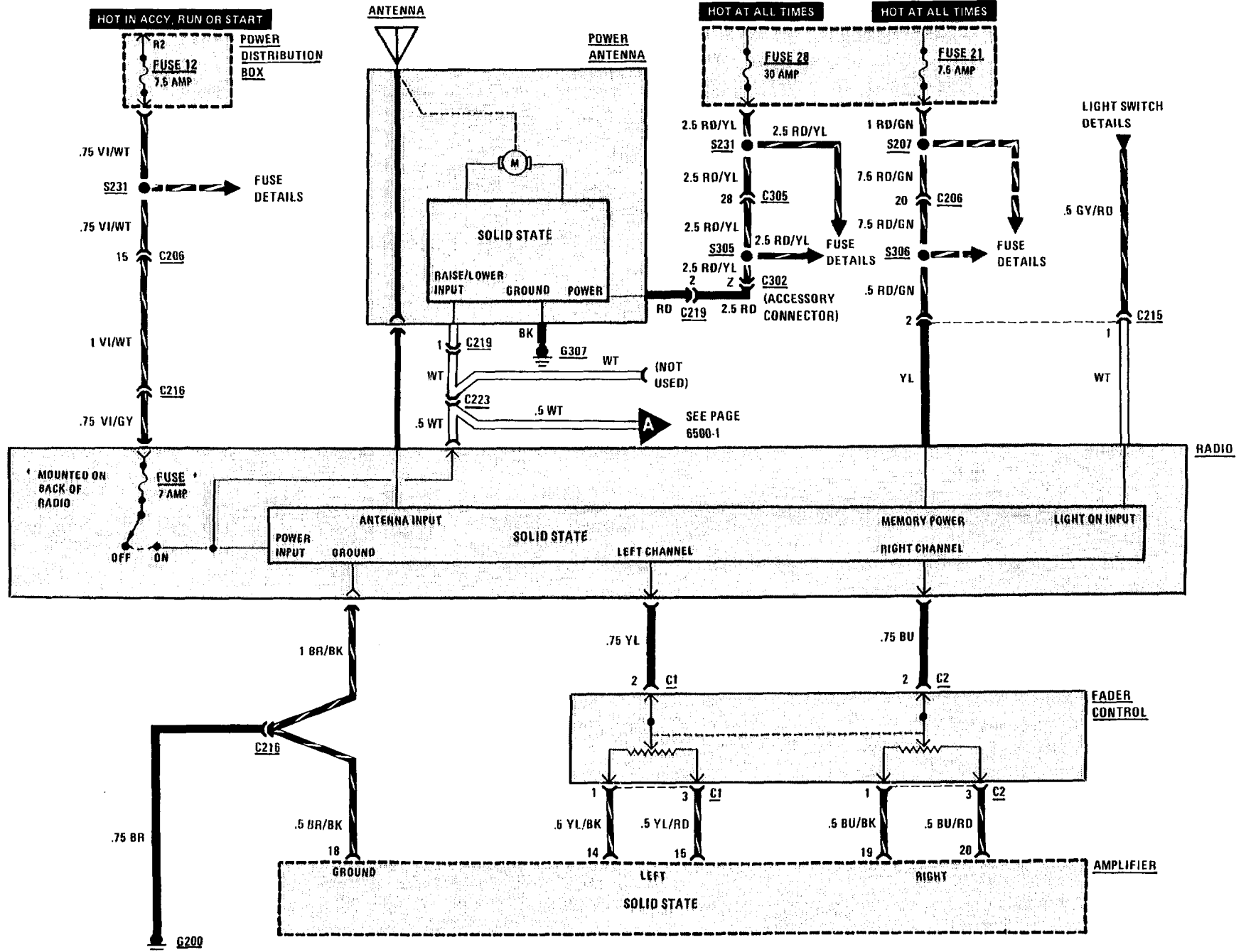

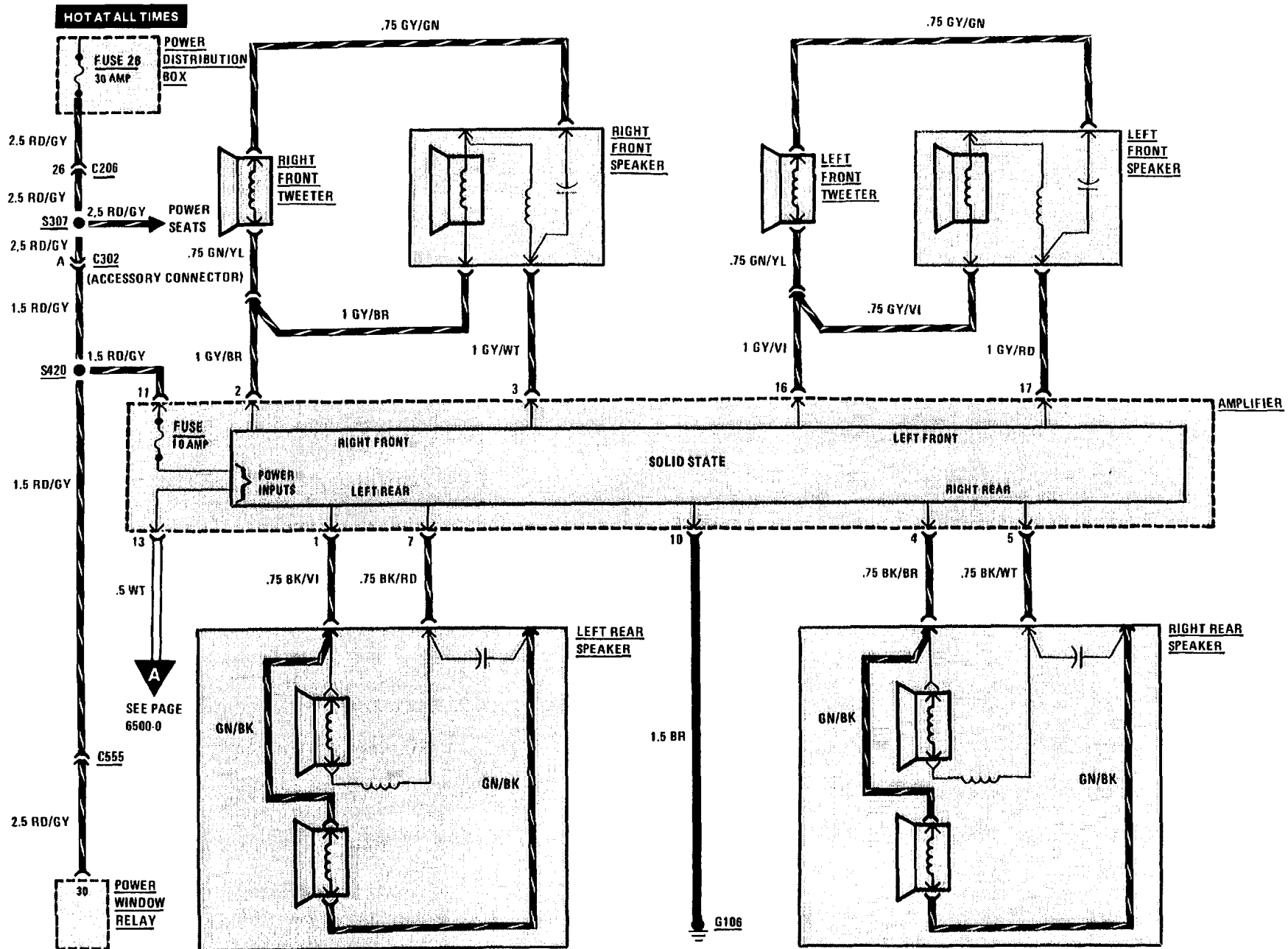

# 6571-0 CRUISE CONTROL

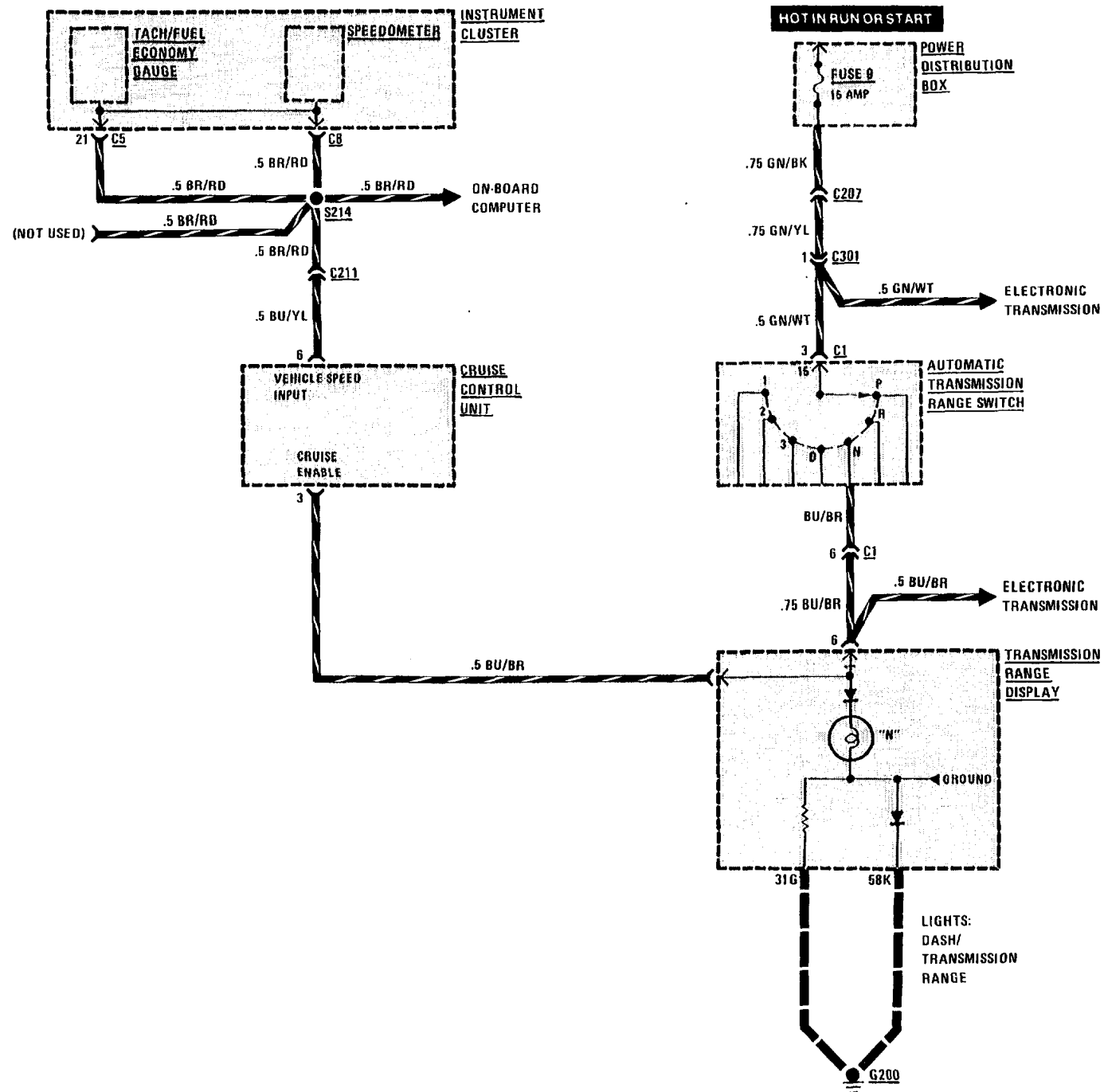







# 6581-2 ON-BOARD COMPUTER

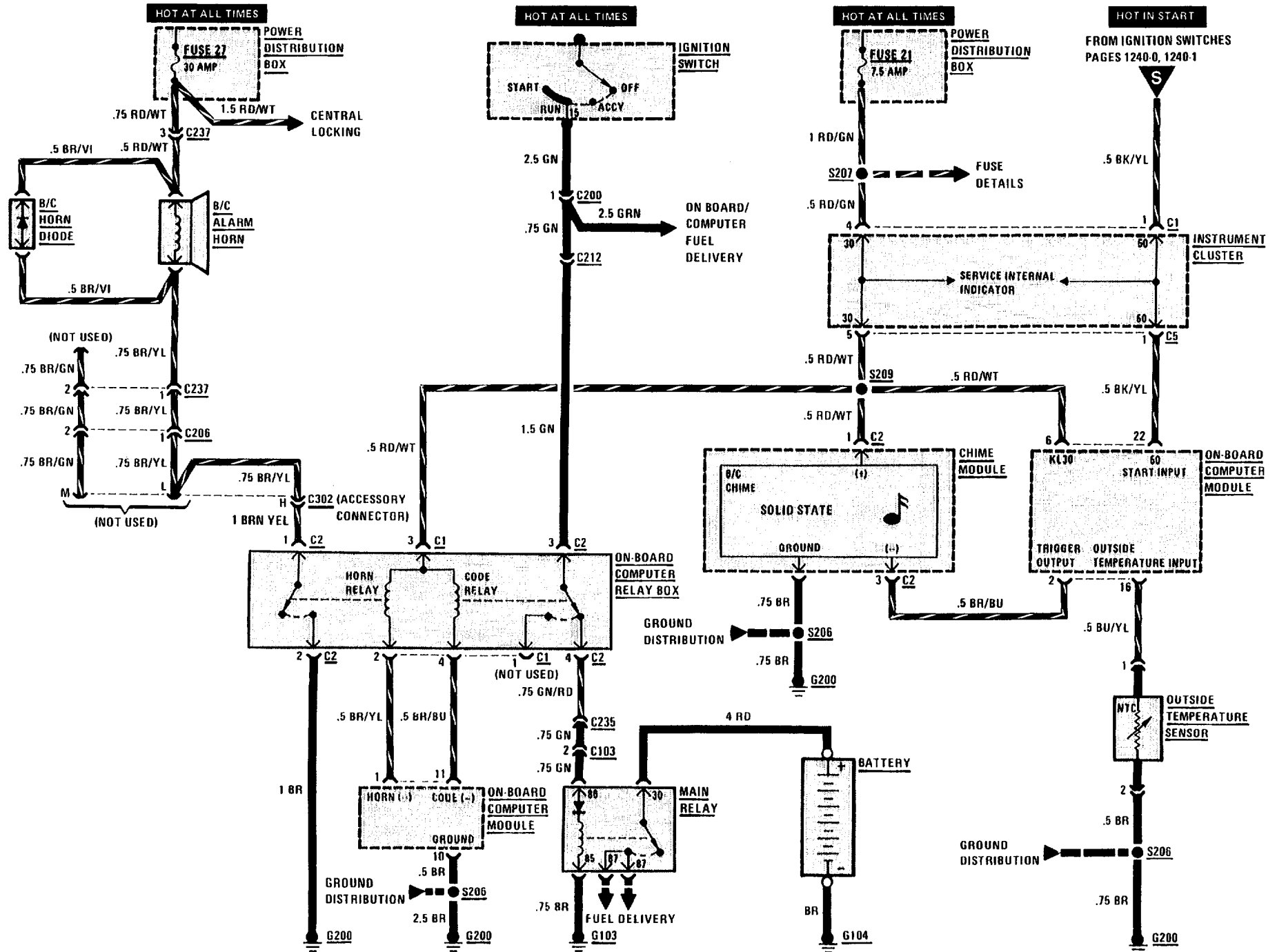

# 7000-0 COMPONENT LOCATION VIEWS

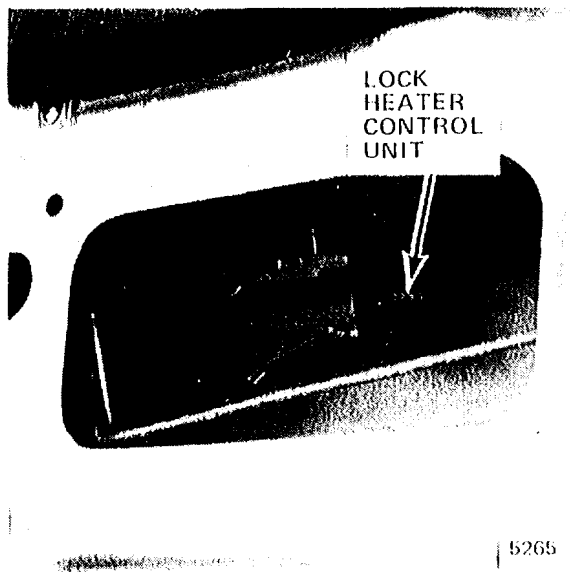

Figure 1 - Inside Driver's Door

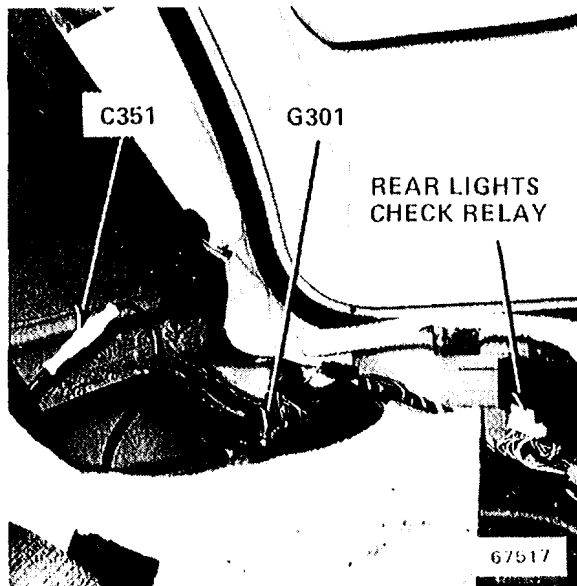

Figure 3 - Under Left Side of Rear Seat

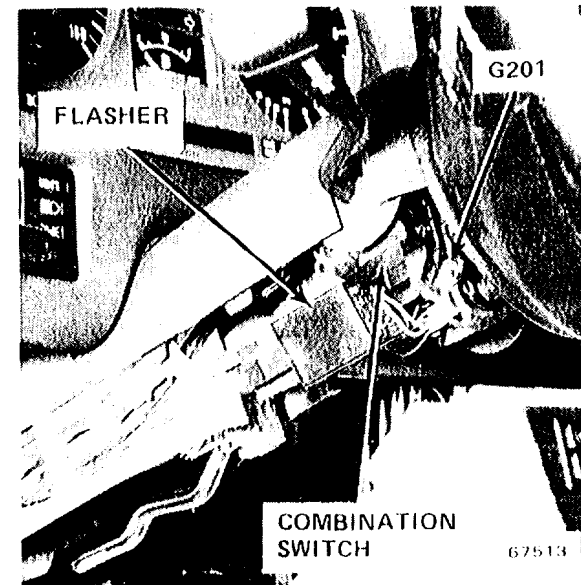

Figure 5 - Upper Underside of Steering Column

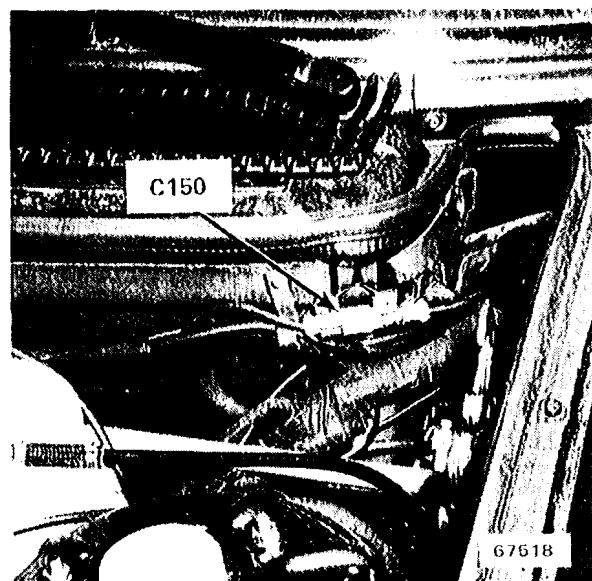

Figure 2 - Left Side of Cowl

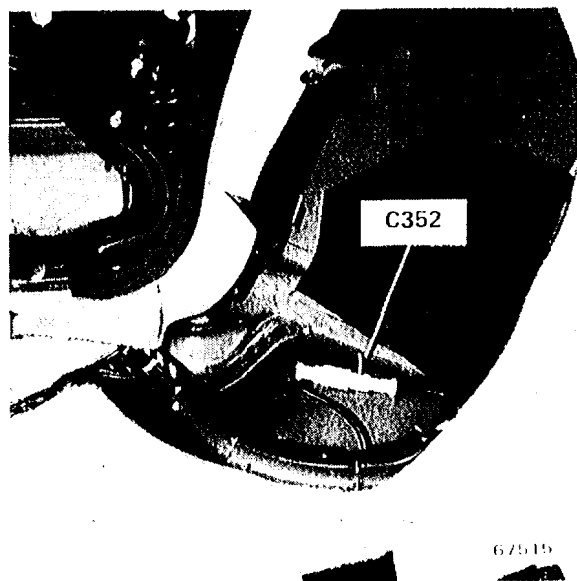

Figure 4 - Under Right Side of Rear Seat

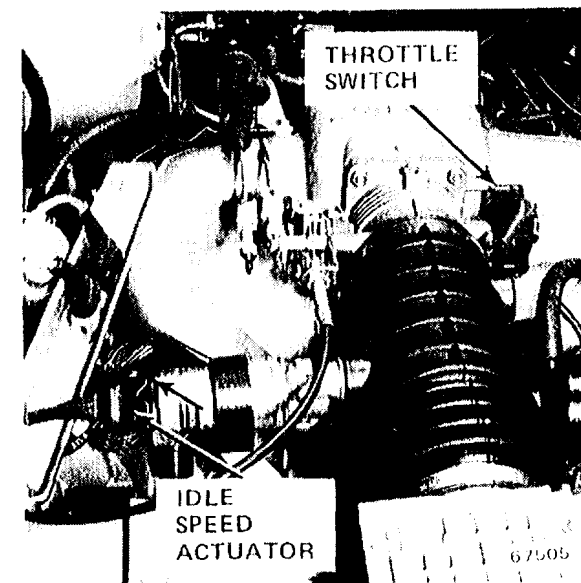

Figure 6 - Top Center of Engine





Figure 1 - Behind Left Side of Console

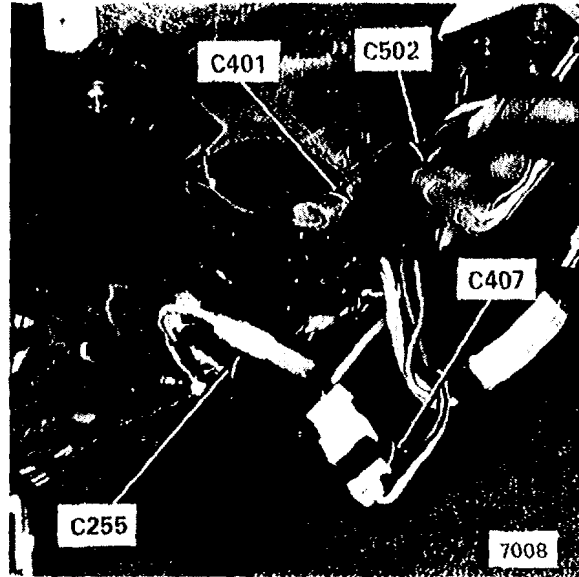

Figure 3 - Right of Glove Box

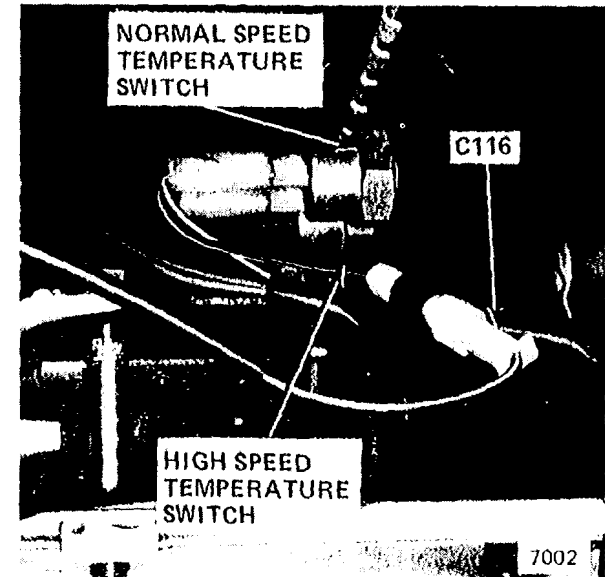

Figure 5 - Right Side of Radiator

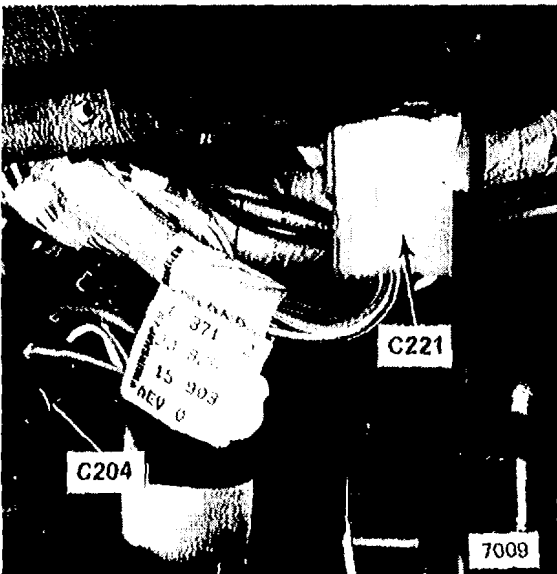

Figure 2 - Left of Glove Box

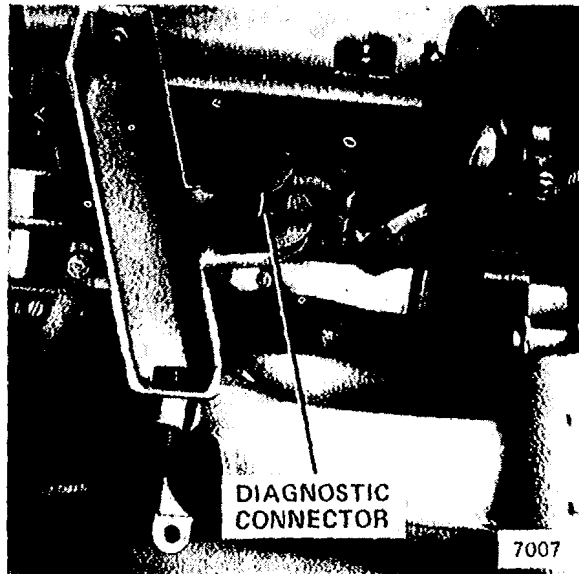

Figure 4 - Top Front of Engine

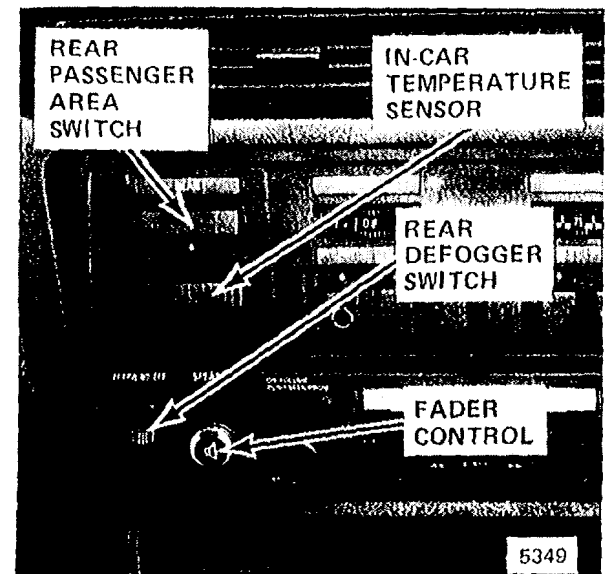

Figure 6 - Center of Dash

7000-2 COMPONENT LOCATION VIEWS

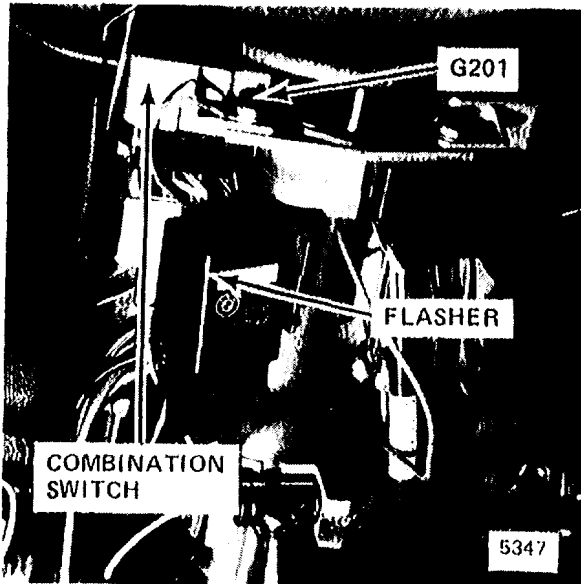

Figure 1 - Upper Underside of Steering Column

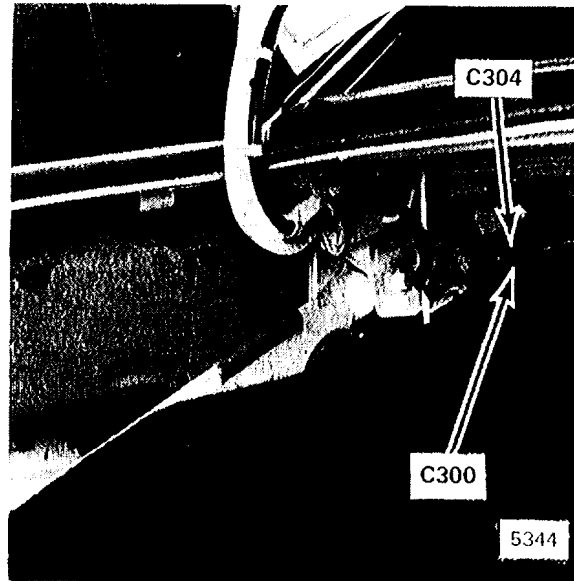

Figure 3 - Left Front of Trunk



Figure 5 - Under Center of Fresh Air Intake Cowl

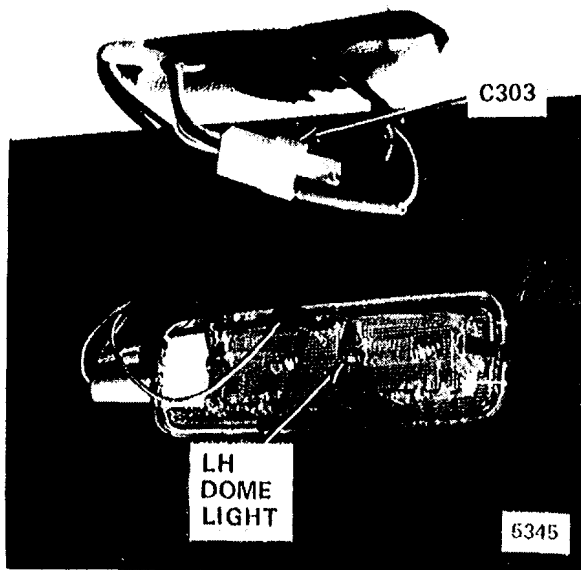

Figure 2 - Above Left "B" Pillar

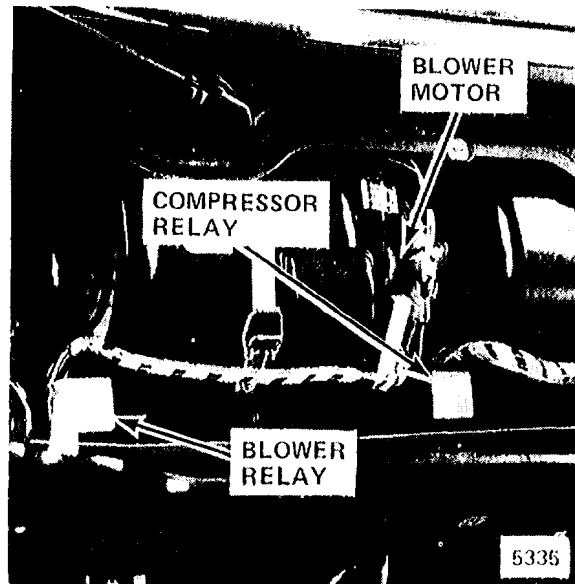

Figure 4 - Under Center of Fresh Air Intake Cowl

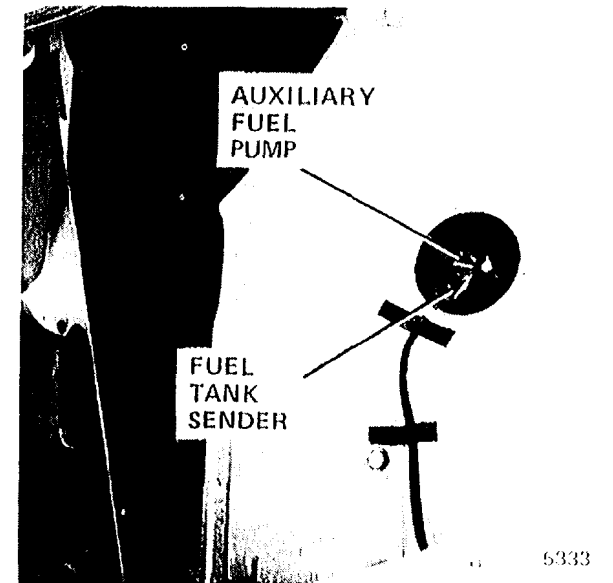

Figure 6 - Bottom Left Side of Trunk

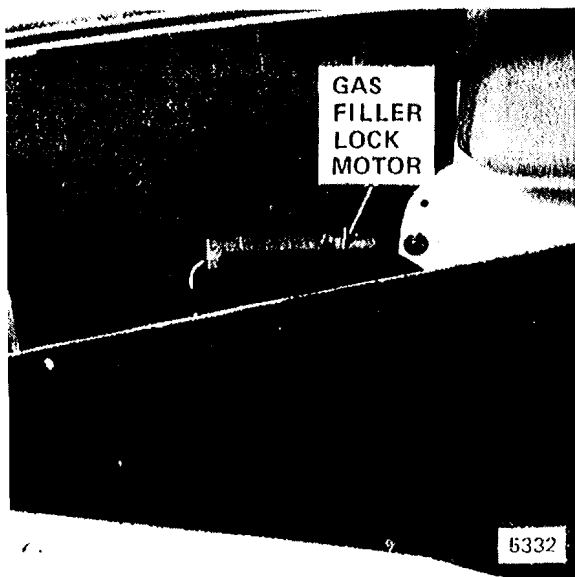

Figure 1 - Behind Left Rear Wheel Well

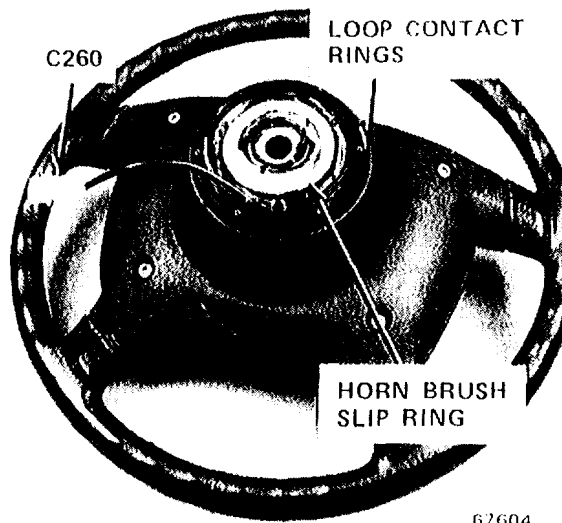

Figure 3 - Rear of Steering Wheel

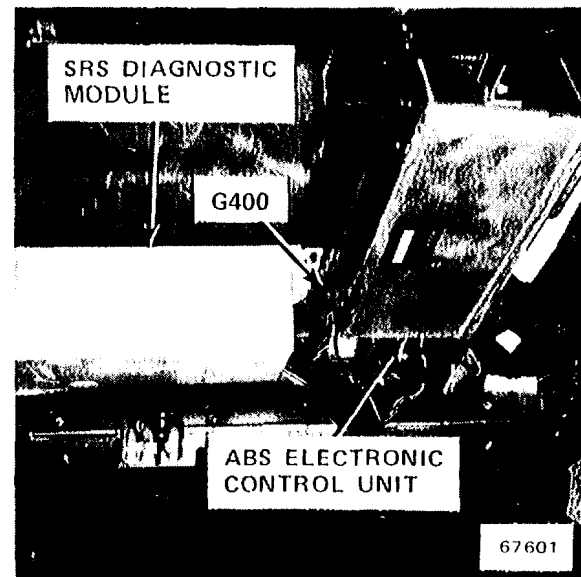

Figure 5 - Above Glove Box Compartment

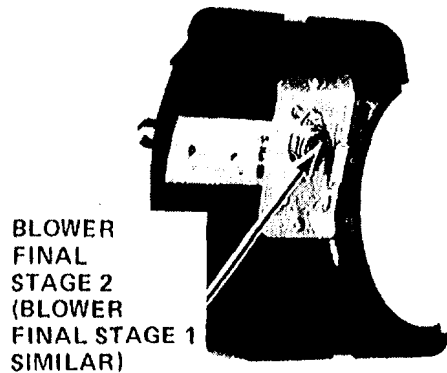

Figure 2 - Removed Left Blower Fan Housing Cover

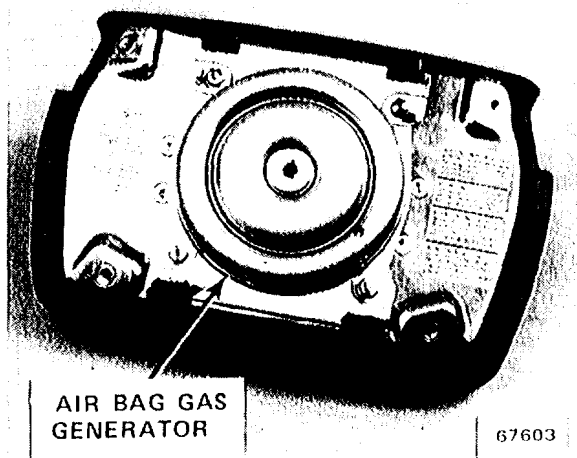

Figure 4 - Rear of Steering Wheel Center Pad

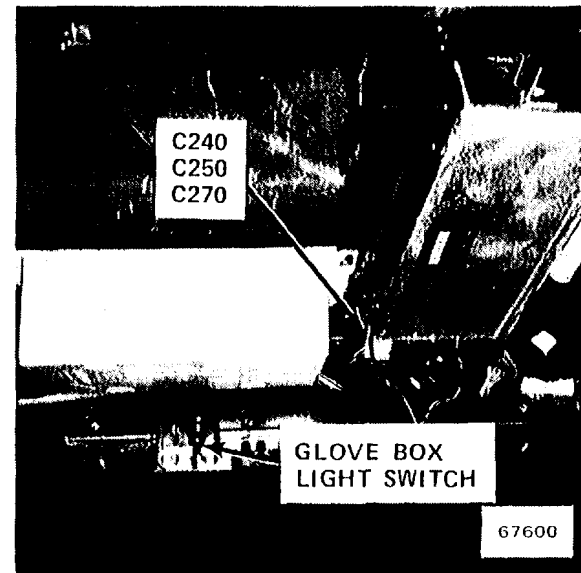

Figure 6 - Above Glove Box Compartment

# 7000-4 COMPONENT LOCATION VIEWS

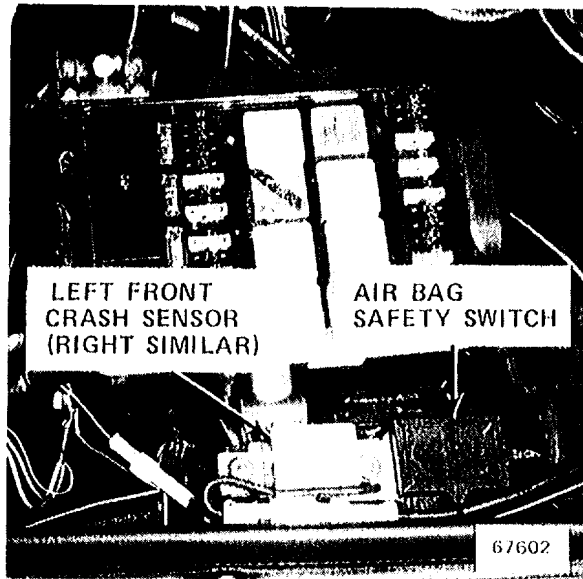

Figure 1 - Top of Left Front Wheel Well

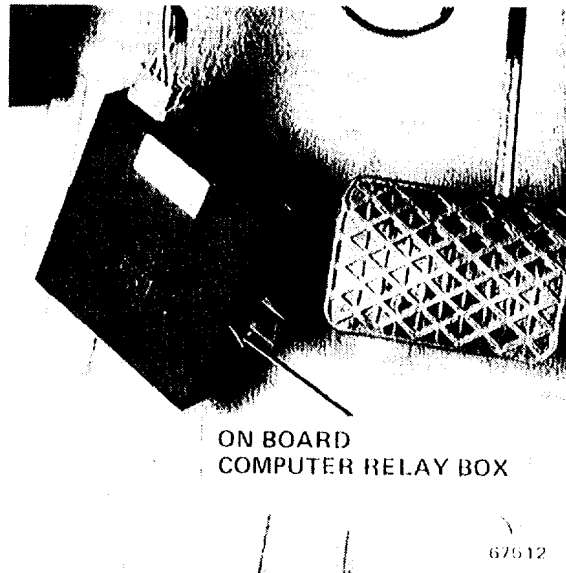

Figure 3 - Below LH Side of Dash

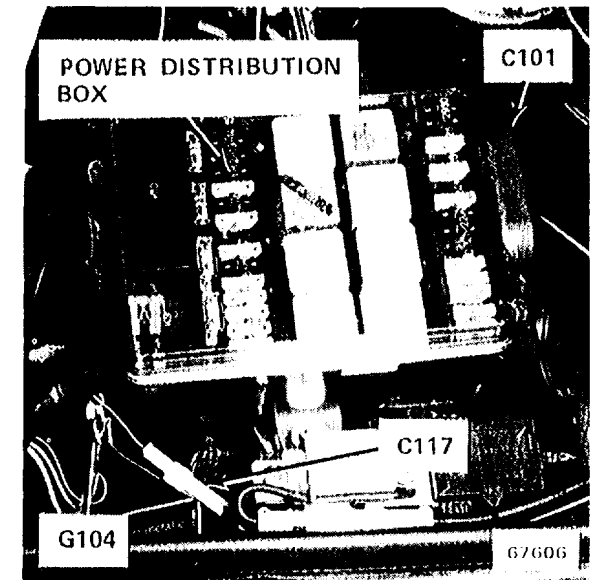

Figure 5 - Top of Left Front Wheel Well

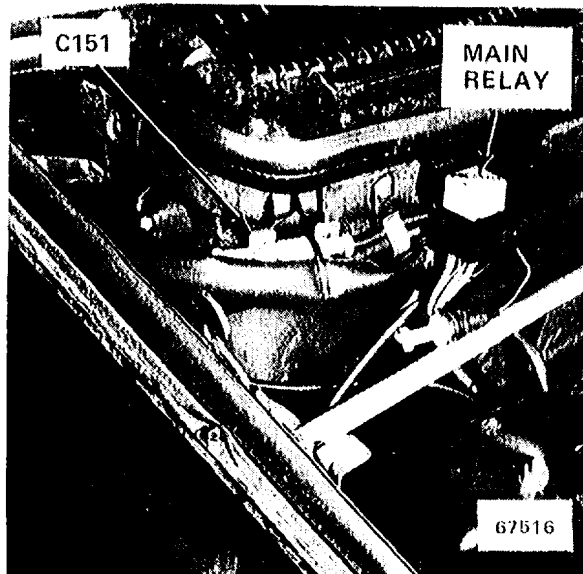

Figure 2 - Behind RH Front Shock Tower

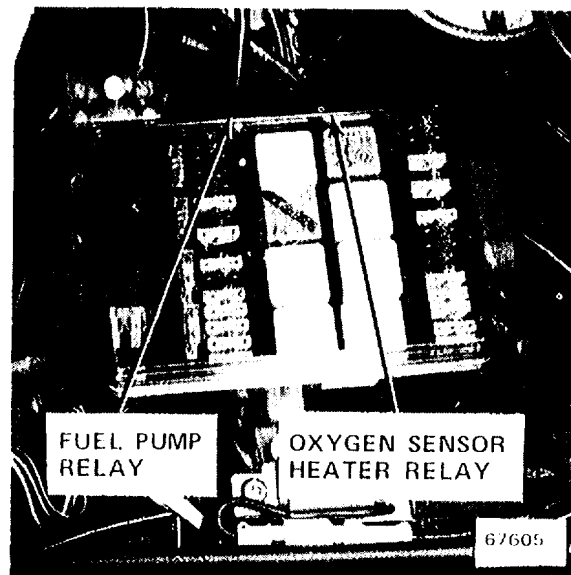

Figure 4 - Top of Left Front Wheel Well

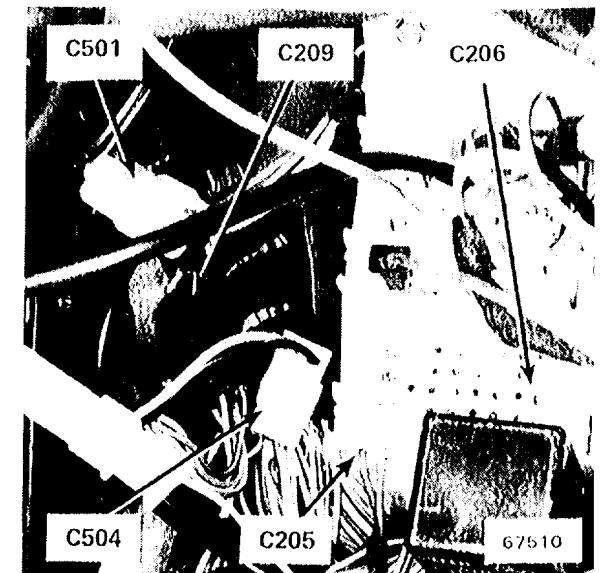

Figure 6 - Behind LH Dash



Figure 1 - Behind LH Dash

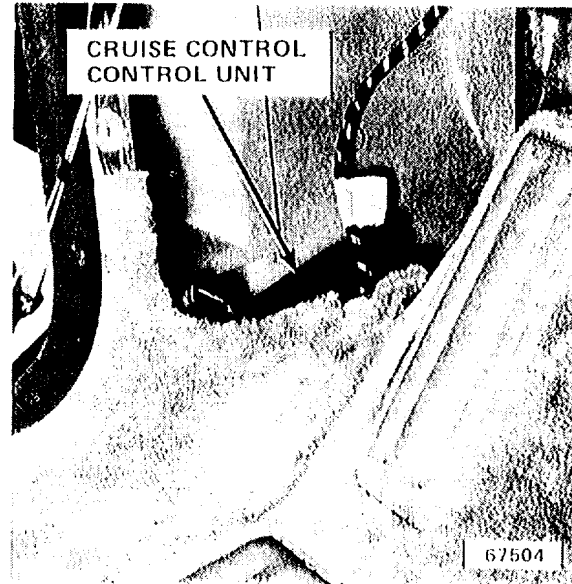

Figure 3 - Behind Left Front Speaker

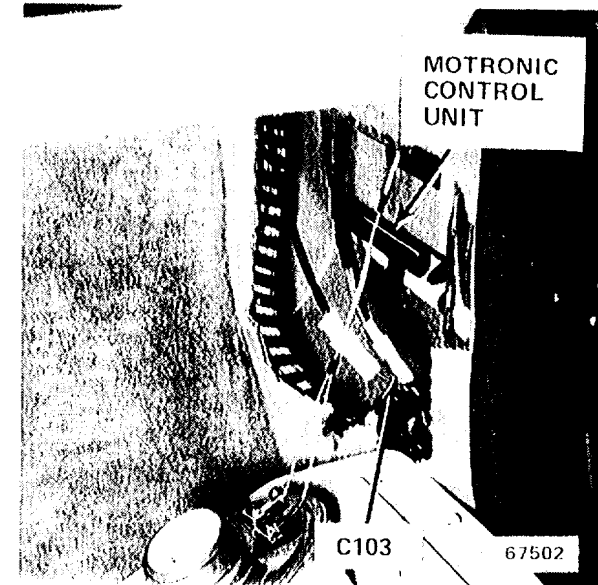

Figure 5 - Behind Right Front Kickpanel Speaker

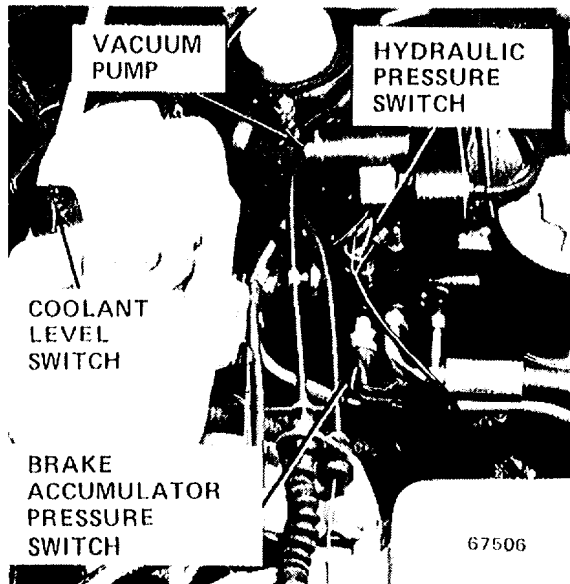

Figure 2 - Left Rear of Engine Compartment



Figure 4 - Left Side of Dash

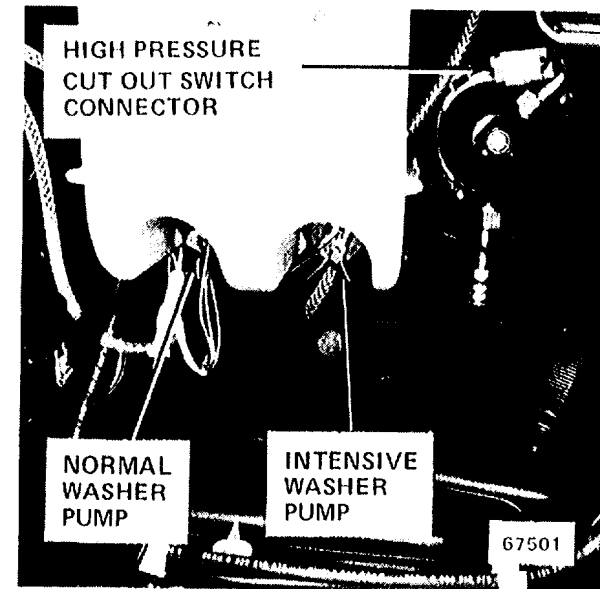

Figure 6 - Ahead of Right Front Wheel Well

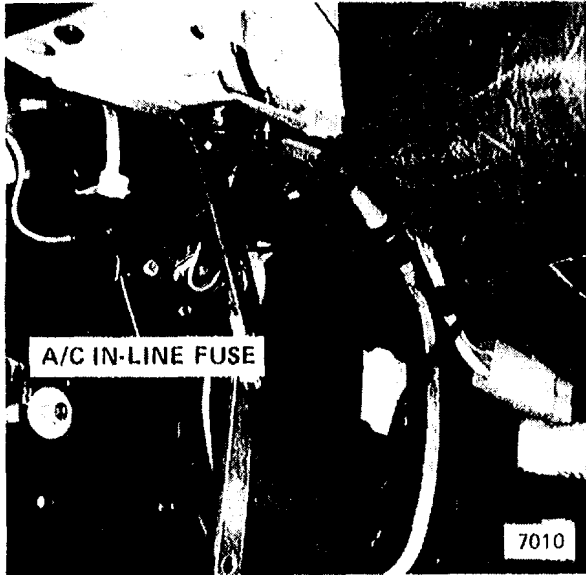

Figure 1 - Left Of Glove Box

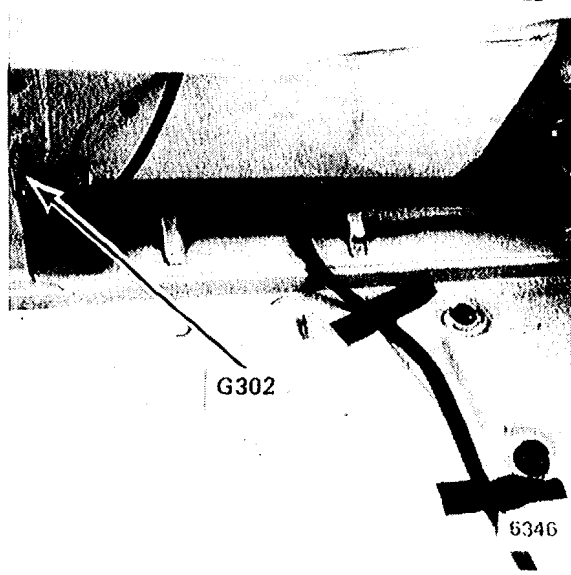

Figure 3 - Left Rear Of Trunk

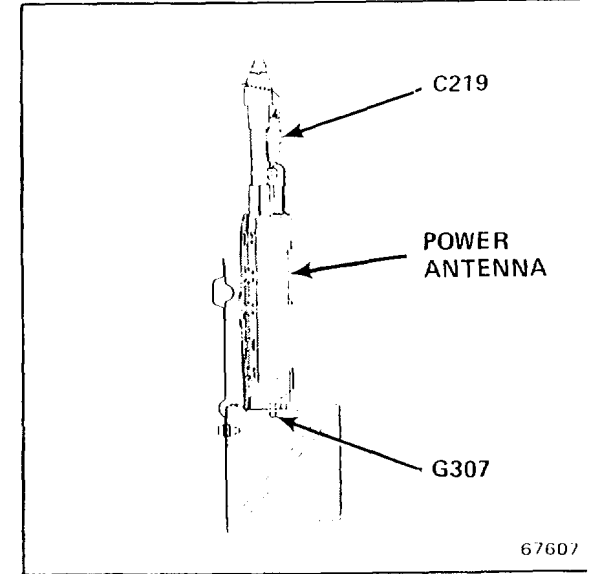

Figure 5 - In Right Side Of Trunk



Figure 2 - Behind Right Headlights

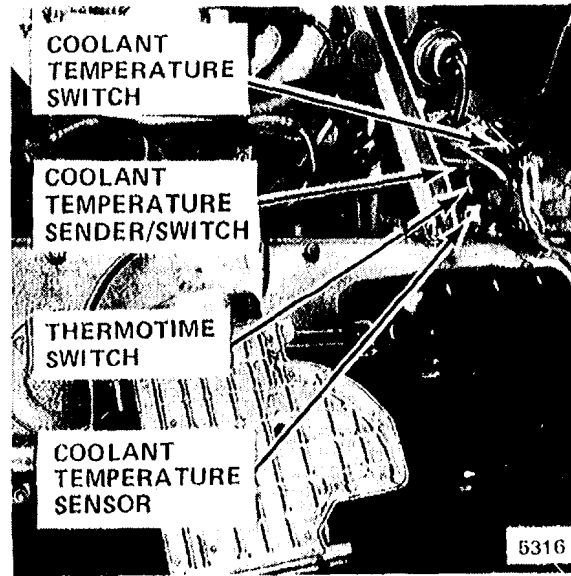

Figure 4 - Top Front Of Engine

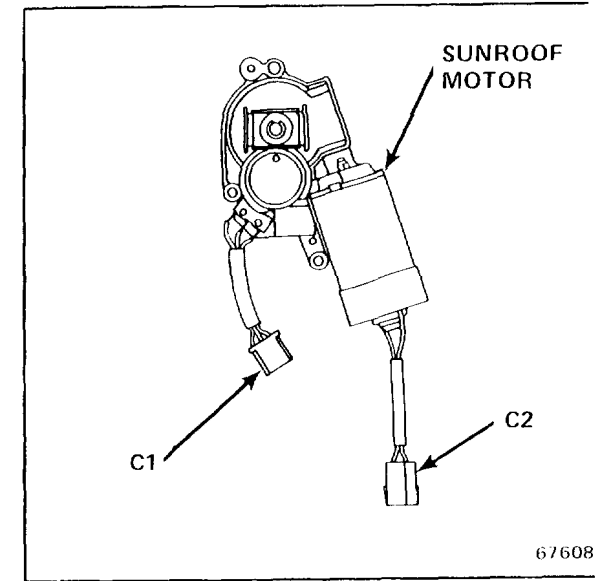

Figure 6 - In Center Of Windshield Header

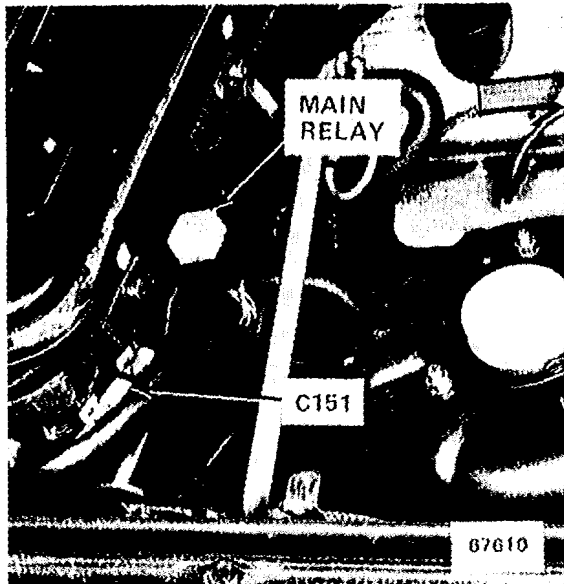

Figure 1 - Behind Right Front Shock Tower

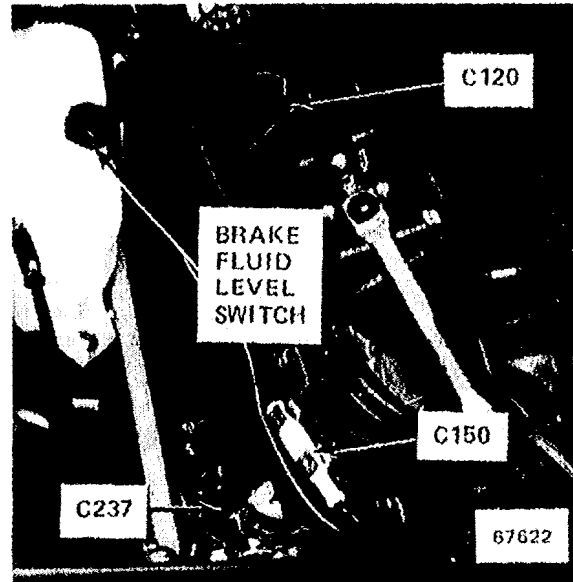

Figure 3 - Behind Left Front Shock Tower

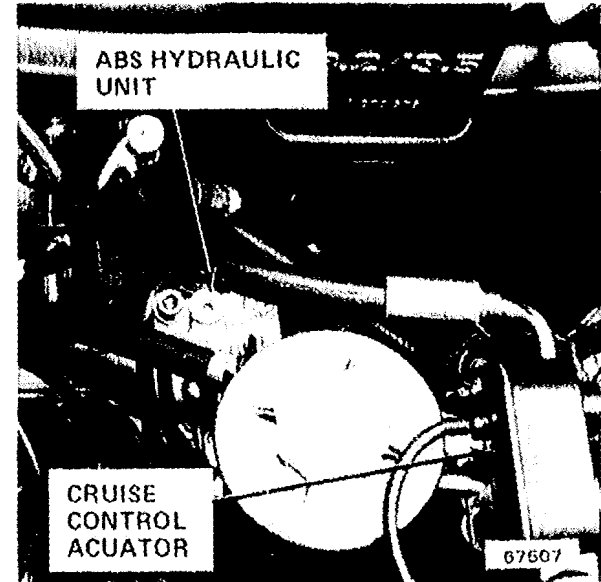

Figure 5 - Behind Right Side of Battery



Figure 2 - Top Rear of Engine

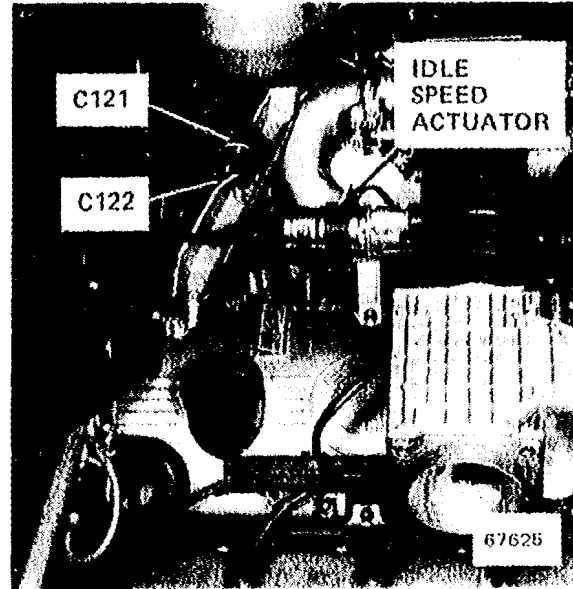

Figure 4 - Top Rear of Engine

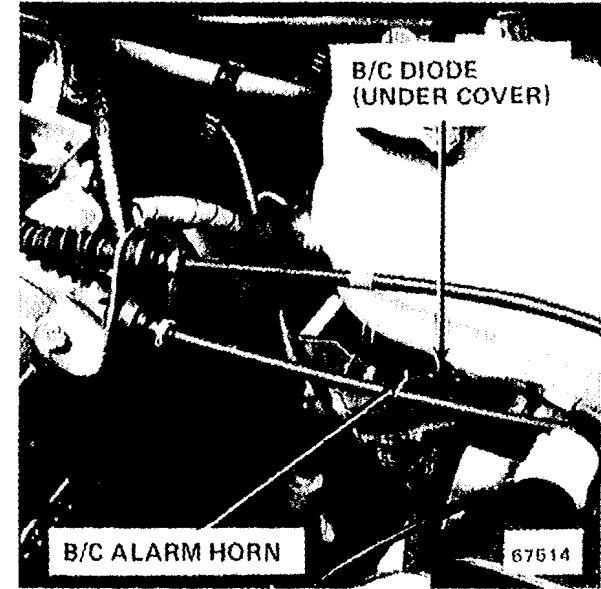

Figure 6 - Lower Left Side of Cowl,  
Below Brake Fluid Reservoir

# 7000-8 COMPONENT LOCATION VIEWS

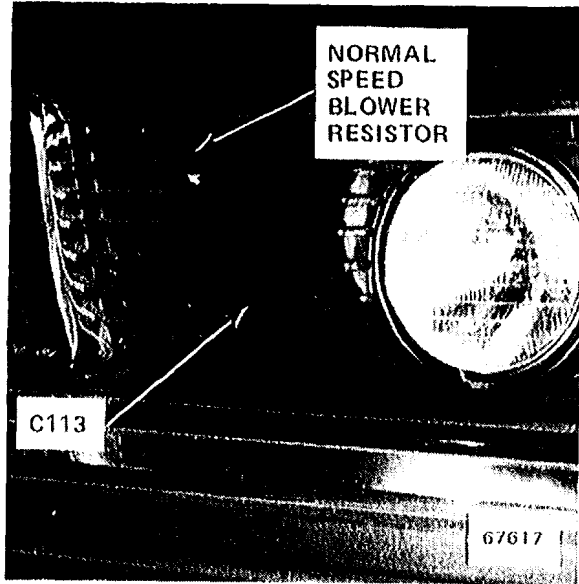

Figure 1 - Front of Car

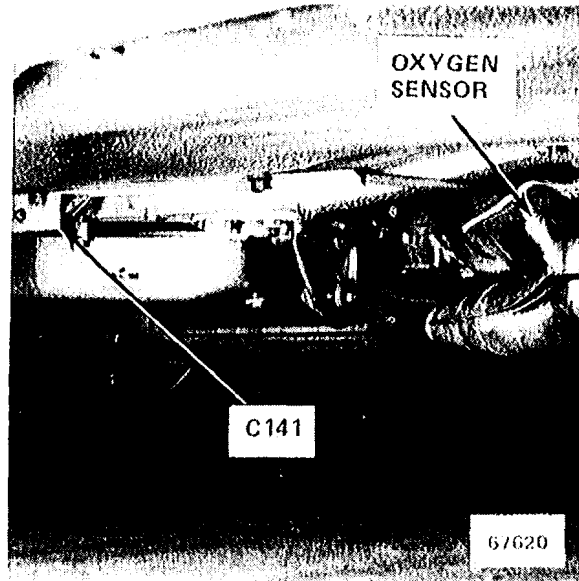

Figure 3 - Under Left Side of Car

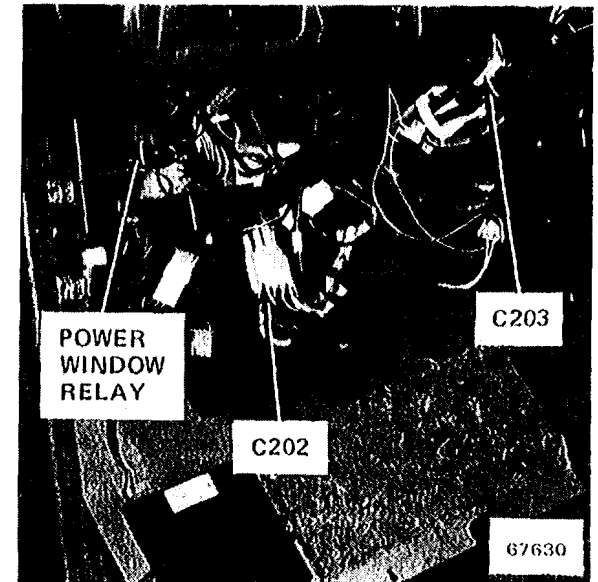

Figure 5 - Behind Left Side of Dash

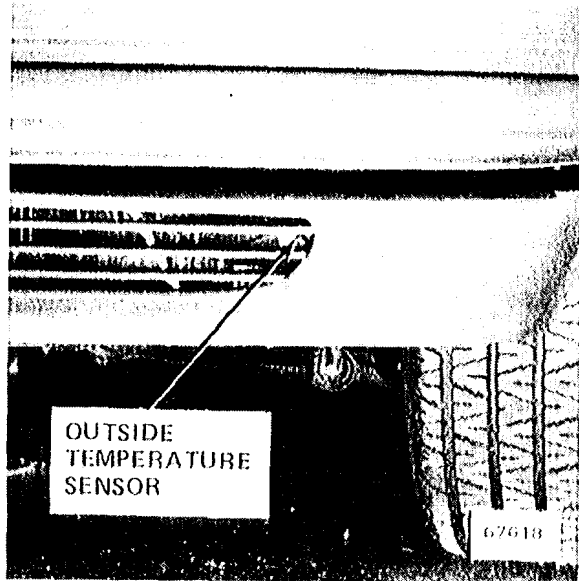

Figure 2 - Lower Left Front of Car

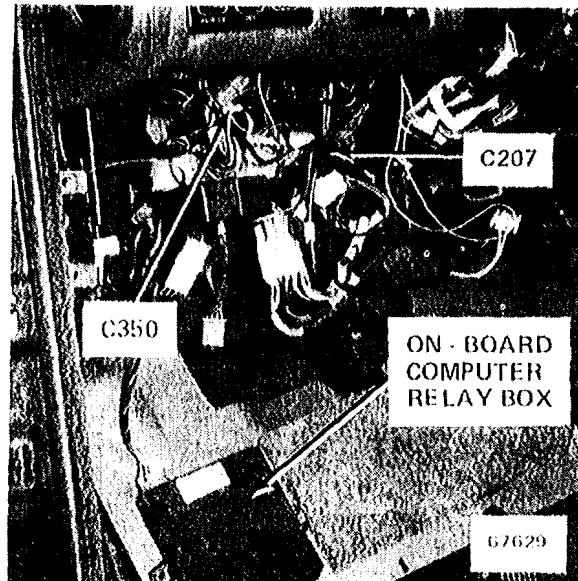

Figure 4 - Behind Left Side of Dash

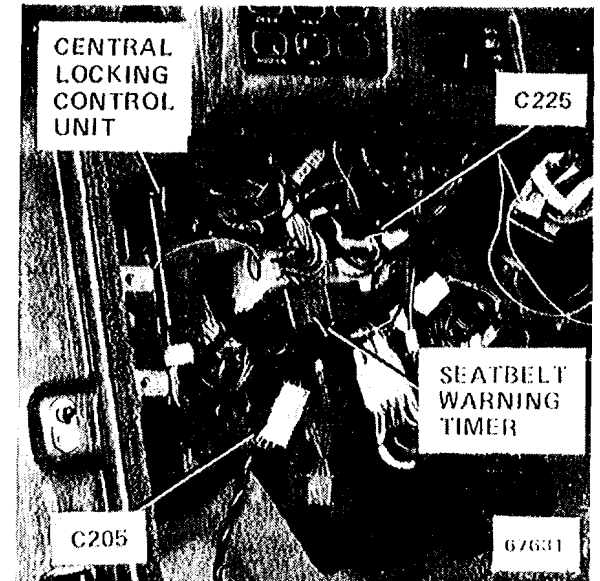

Figure 6 - Behind Left Side of Dash



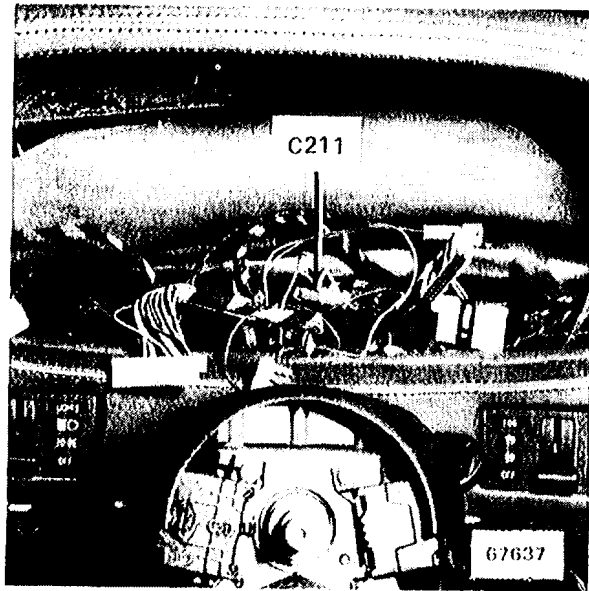

Figure 1 - Behind Instrument Cluster

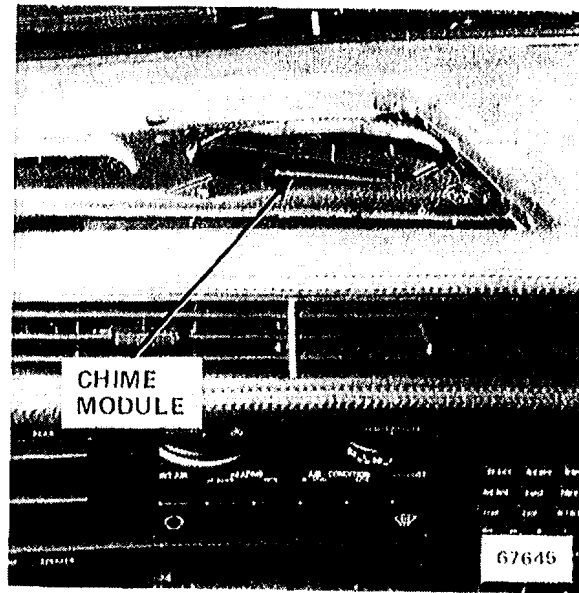

Figure 3 - Top Center of Dash (Grill Removed)

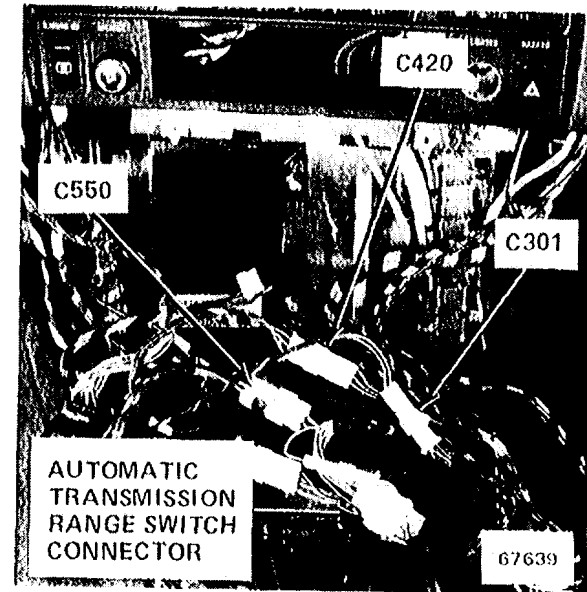

Figure 5 - Below Front of Console

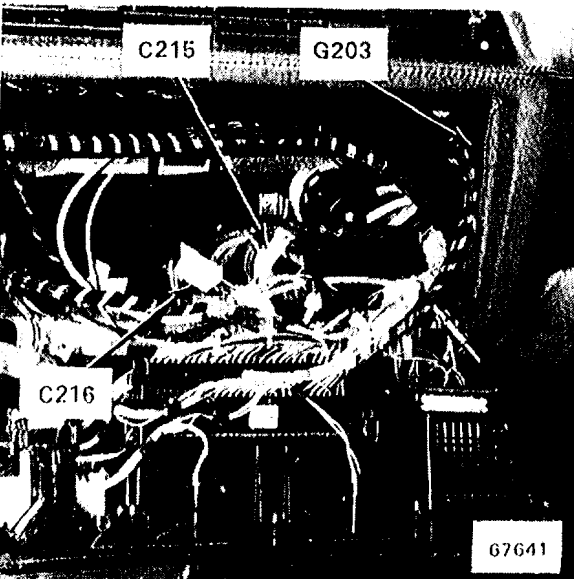

Figure 2 - Behind Center of Dash

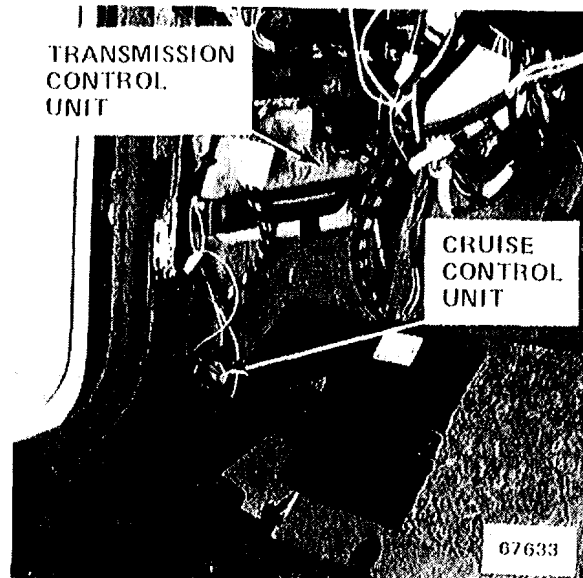

Figure 4 - Behind Left Kick Panel

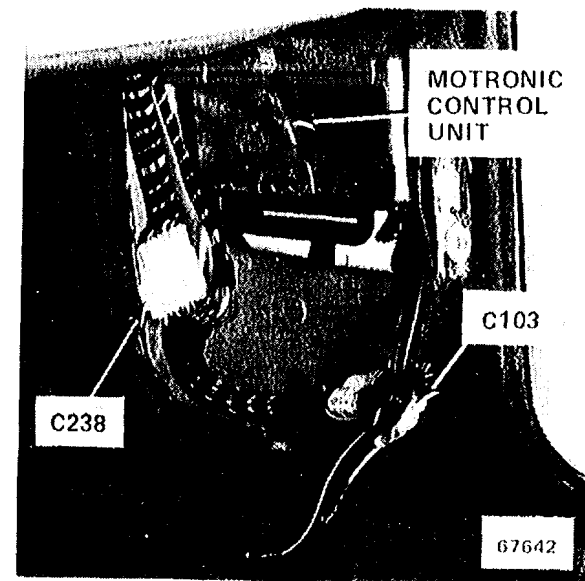

Figure 6 - Behind Right Kick Panel

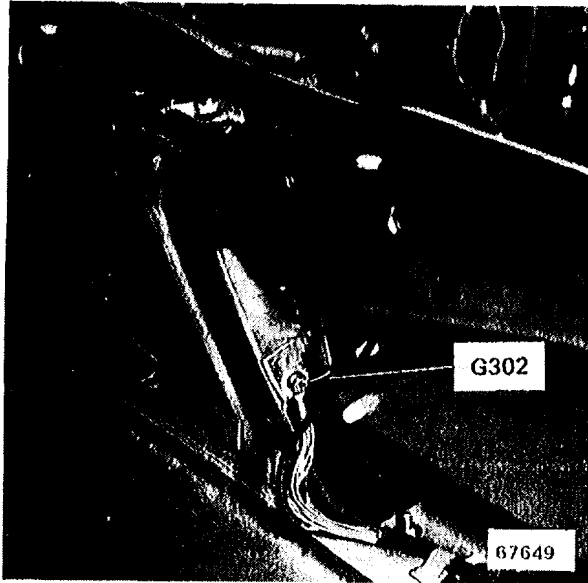

Figure 1 - Center of End Panel, In Trunk

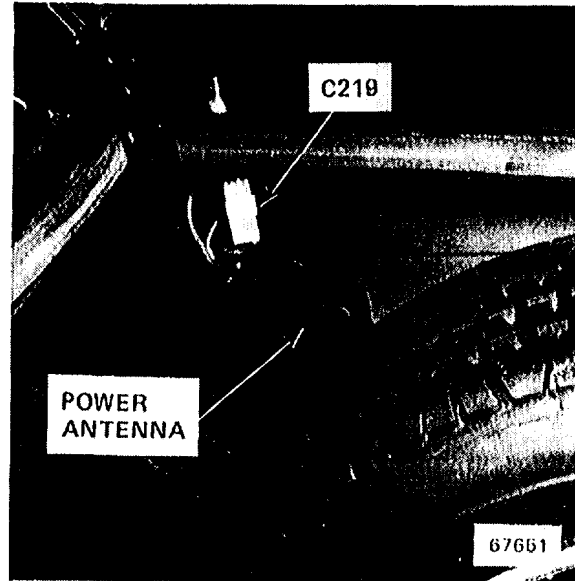

Figure 3 - Right Front of Trunk

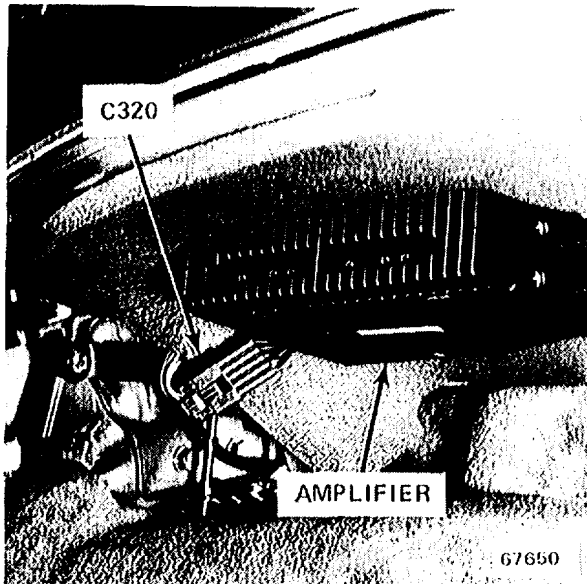

Figure 2 - Left Front of Trunk

## 8000-0 SPLICE LOCATION VIEWS

### SPLICE LOCATION INDEX

This index contains all the splices in the car, what harness each one is in, and the page that the splices appear on. The drawings after the index show how the harness is routed through the car and where the splices are located on the harness.

SPLICE	HARNESS	PAGE NUMBER	SPLICE	HARNESS	PAGE NUMBER	SPLICE	HARNESS	PAGE NUMBER
S100	FRONT	8000-4	S231	MIDDLE	8000-5	S329	REAR	8000-3
S101	FRONT	8000-4	S233	CRUISE CONTROL	NOT SHOWN	S330	REAR	8000-3
S106	ENGINE	8000-6	S241	CRUISE CONTROL	NOT SHOWN	S331	REAR	8000-3
S108	ENGINE	8000-6				S332	A/C	NOT SHOWN
S109	ENGINE	8000-6	S304	REAR	8000-3	S342	A/C	8000-2
S110	ENGINE	8000-6	S305	REAR	8000-3	S351	A/C	8000-2
S150	ABS	8000-1	S306	REAR	8000-3	S355	A/C	8000-2
S151	ABS	8000-1	S307	REAR	8000-3	S400	POWER	NOT SHOWN
S152	ABS	8000-1	S310	REAR	3000-3	S401	POWER	NOT SHOWN
S201	MIDDLE	8000-5	S311	REAR	8000-3	S402	POWER	NOT SHOWN
S203	MIDDLE	8000-5	S312	REAR	8000-3	S414	POWER	NOT SHOWN
S204	MIDDLE	8000-5	S314	REAR	8000-3	S502	DOOR	NOT SHOWN
S205	MIDDLE	8000-5	S315	REAR	8000-3	S503	DOOR	NOT SHOWN
S206	B/C	NOT SHOWN	S317	REAR	8000-3	S504	DOOR	NOT SHOWN
S207	MIDDLE	8000-5	S319	REAR	8000-3	S510	DOOR	NOT SHOWN
S208	MIDDLE	8000-5	S320	REAR	8000-3	S600	SUNROOF	NOT SHOWN
S209	B/C	NOT SHOWN	S321	REAR	8000-3	S601	SUNROOF	NOT SHOWN
S210	MIDDLE	8000-5	S322	REAR	8000-3			
S211	MIDDLE	8000-5	S323	REAR	8000-3			
S212	MIDDLE	8000-5	S324	REAR	8000-3			
S213	MIDDLE	8000-5	S325	REAR	8000-3			
S214	B/C	NOT SHOWN	S326	REAR	8000-3			
S215	MIDDLE	8000-5	S327	REAR	8000-3			
S219	MIDDLE	8000-5						
S220	MIDDLE	8000-5						
S223	MIDDLE	8000-5						
S224	CRUISE CONTROL	NOT SHOWN						

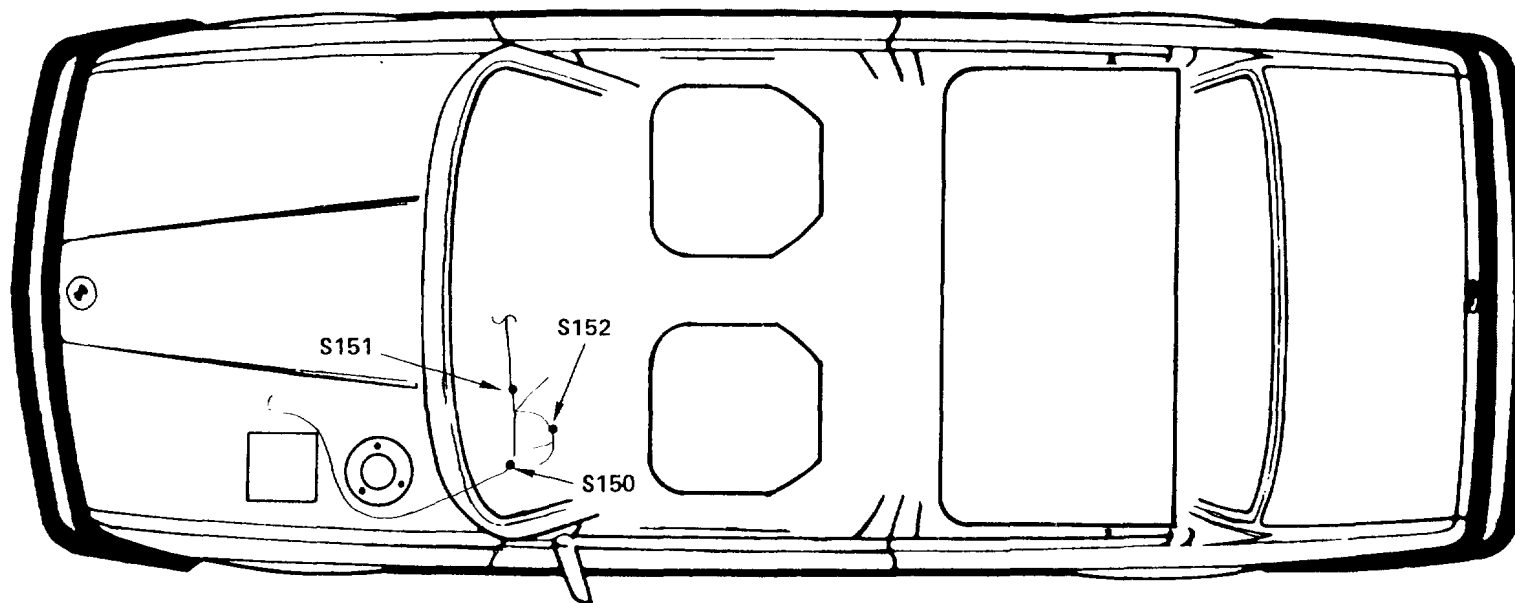

8000-2 SPLICE LOCATION VIEWS

A/C HARNESS

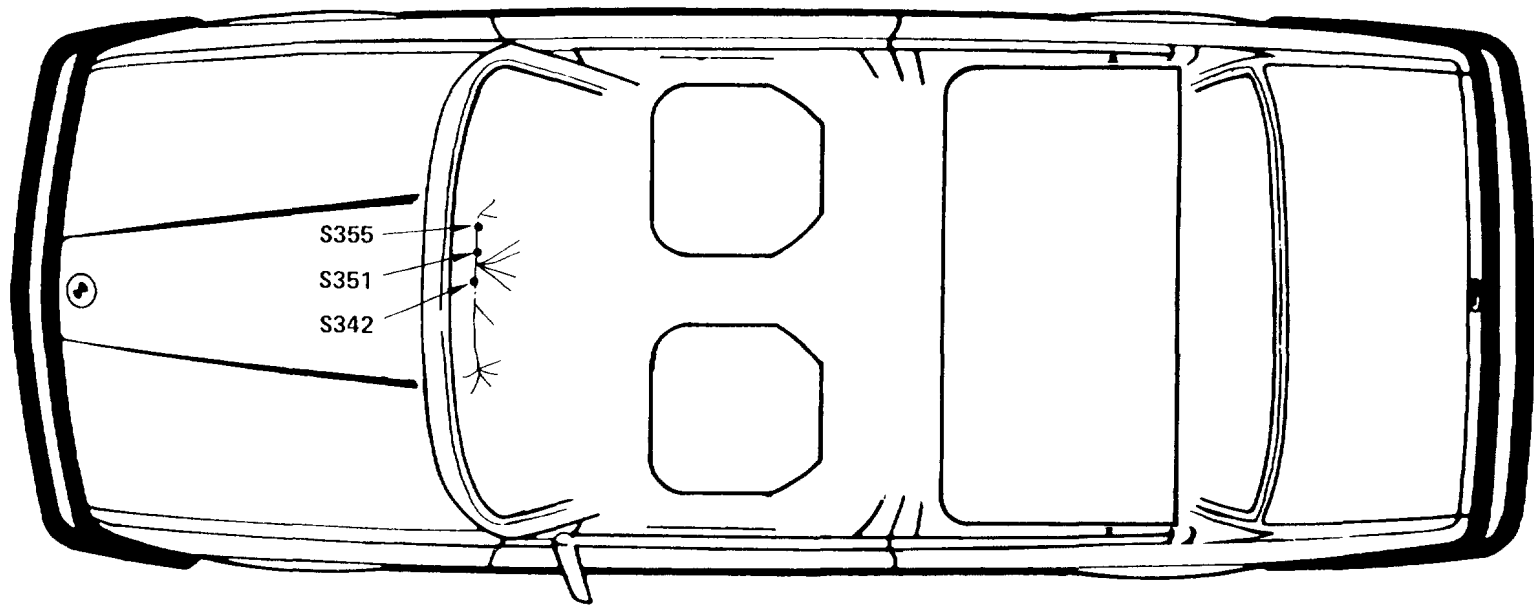

REAR HARNESS

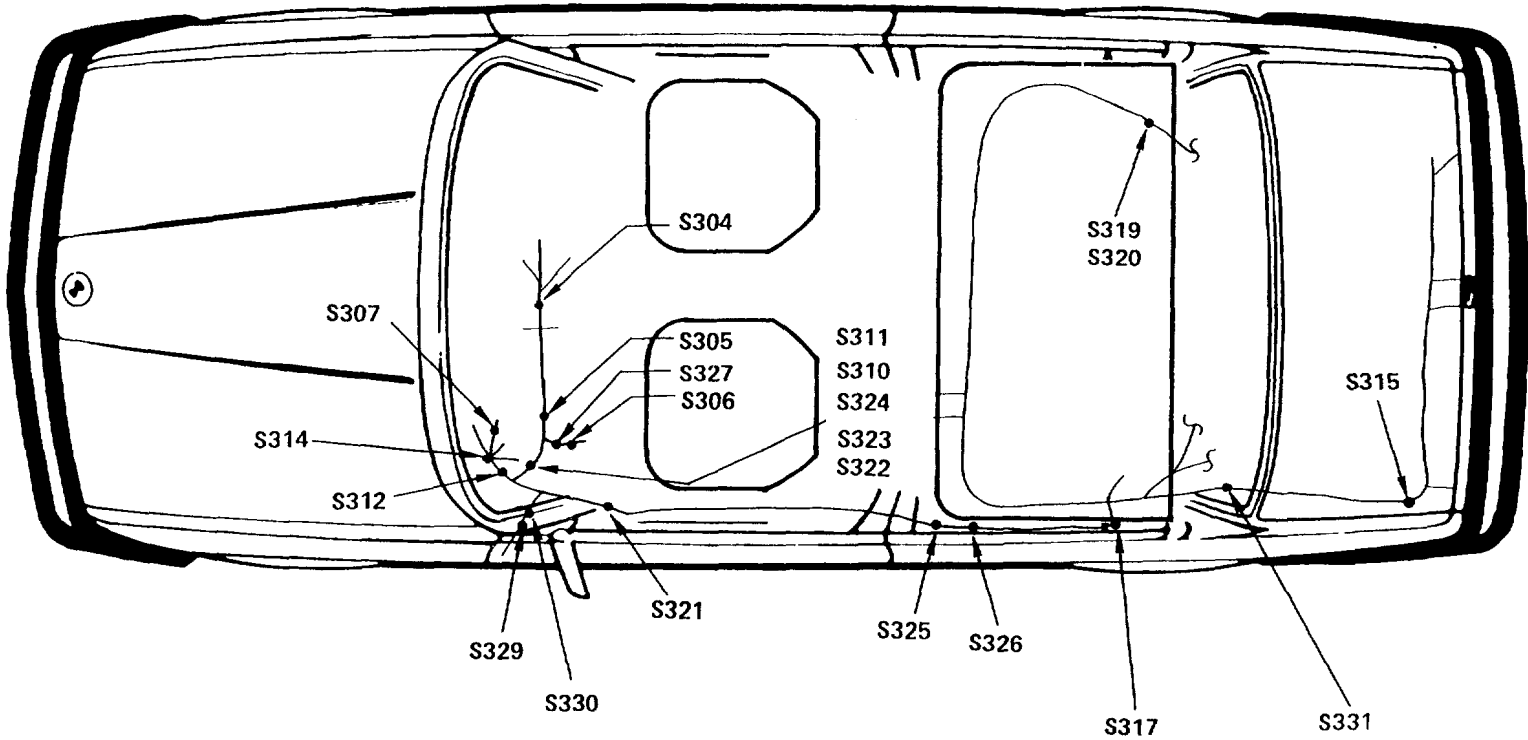

8000-4 SPLICE LOCATION VIEWS

FRONT HARNESS

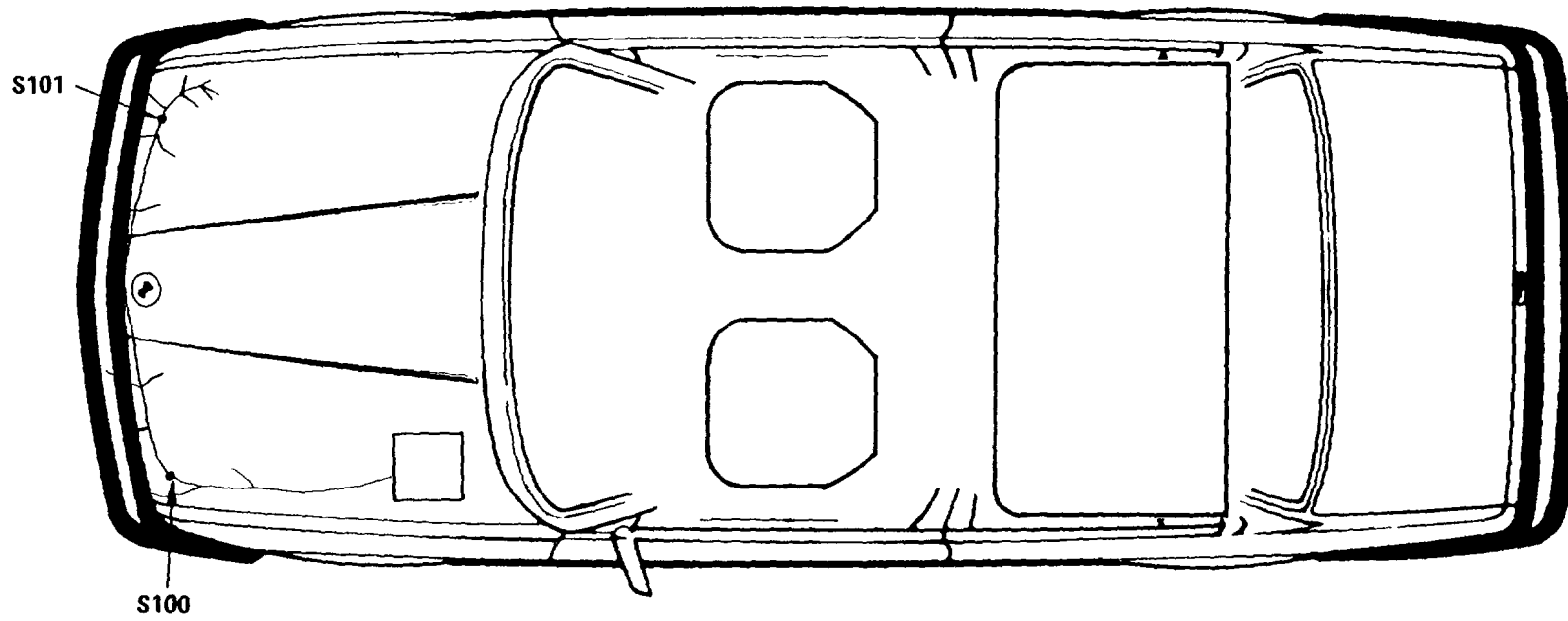

MIDDLE HARNESS

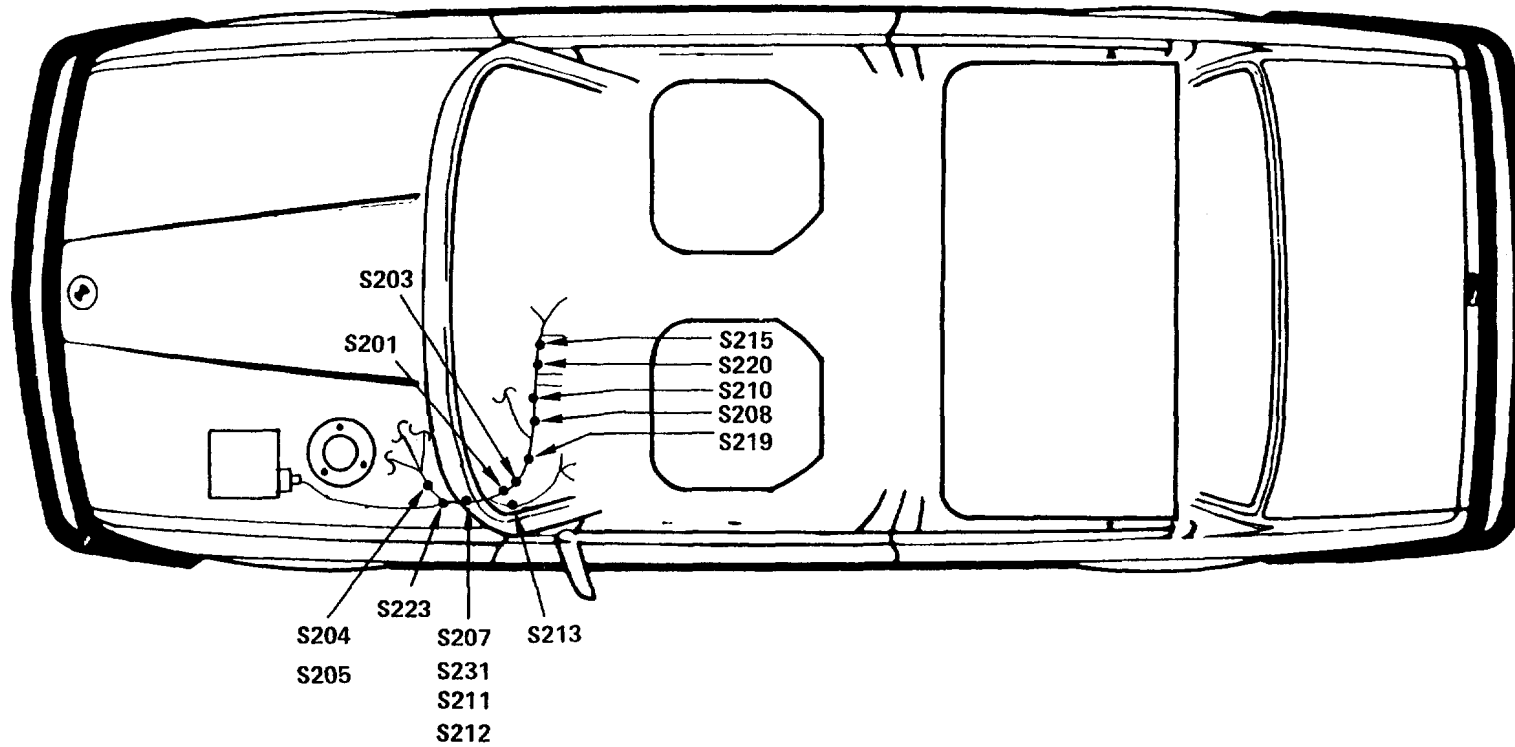



8000-6 SPLICE LOCATION VIEWS

ENGINE HARNESS

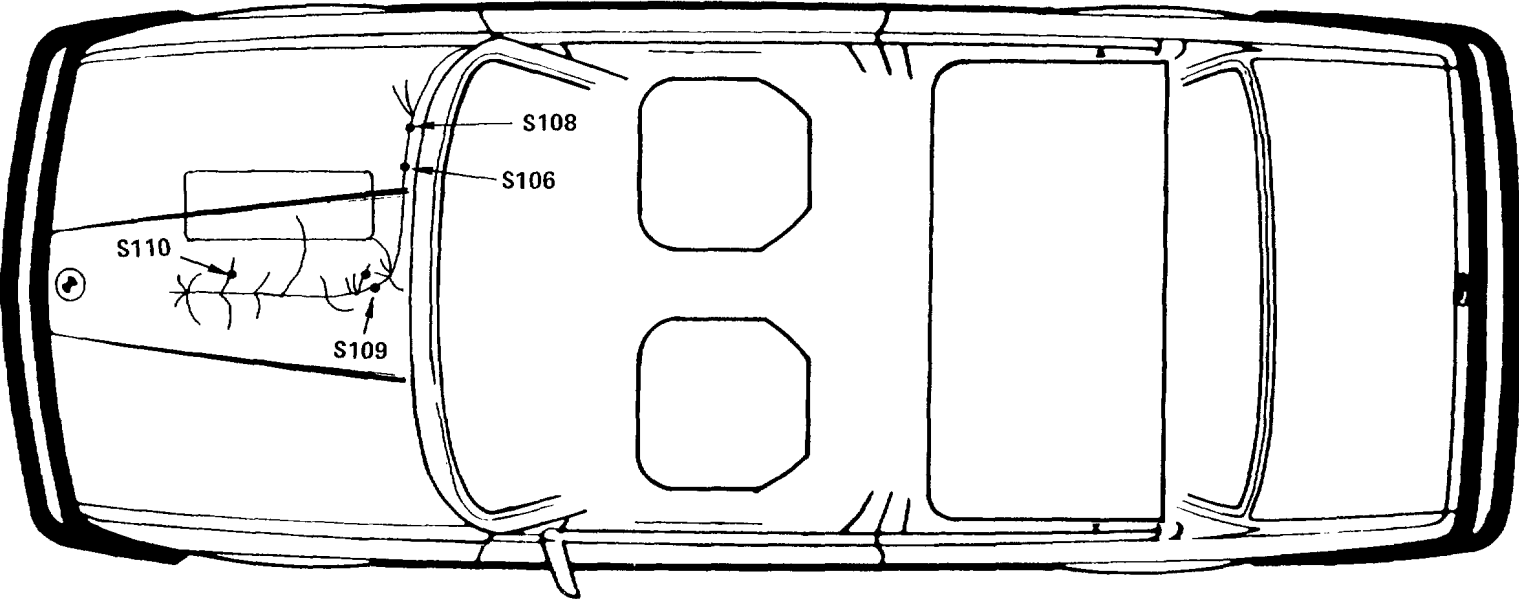

# 8500-0 CONNECTOR VIEWS

## ACCESSORY CONNECTORS

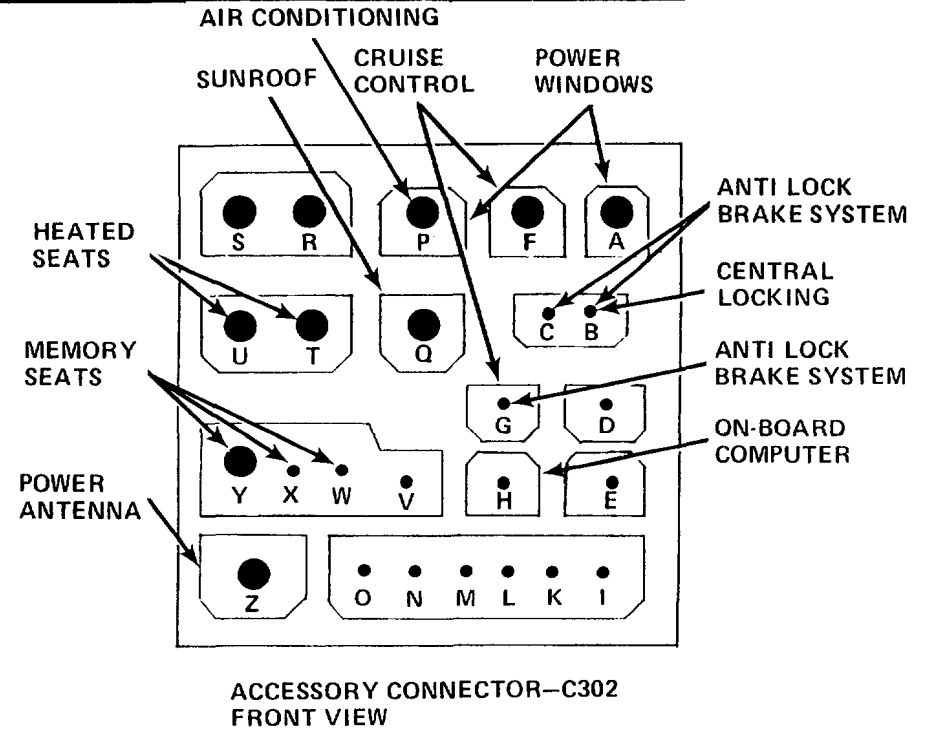
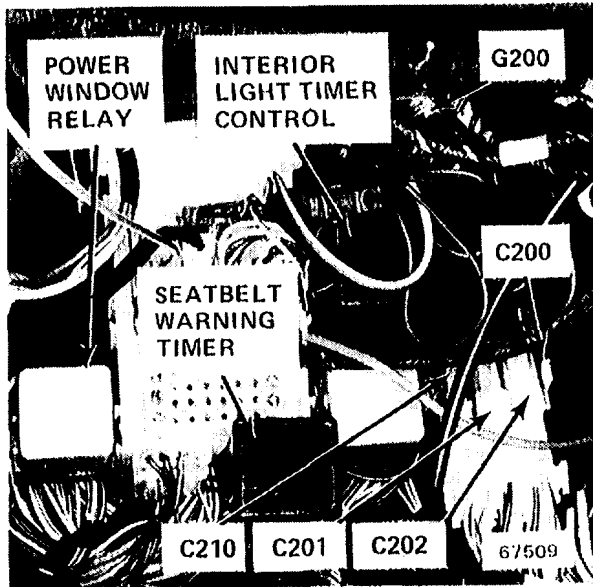
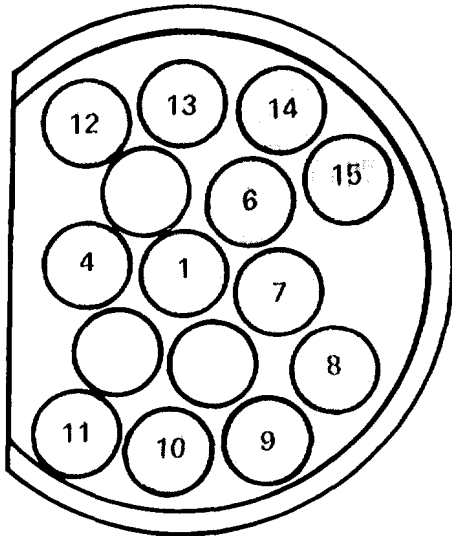

Figure 1 - Under Left Side Of Dash



DIAGNOSTIC CONNECTOR FACE

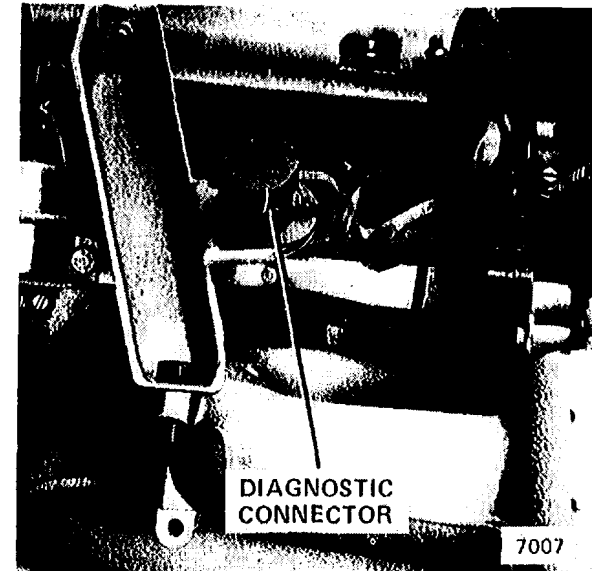
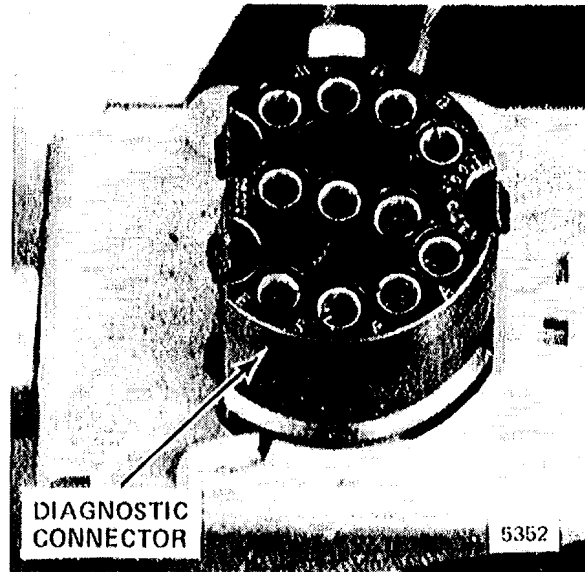
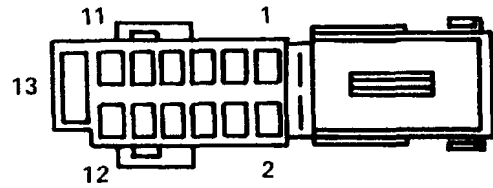

Figure 1 - Top Front of Engine

PIN	WIRE SIZE	WIRE COLOR	CIRCUIT AND COMPONENT CONNECTED
1	1.5	BR	Ground Distribution, G103.
4	.5	BR/WT	Gauges/Warning Indicators. Coolant Temperature Sender
6	.5	WT/BK	Not Used.
7	.5	WT/BU	Service Interval Indicator. Service Interval Processor.
8	.5	YL	Ignition, TDC Sensor
9		SHIELD	Ignition, TDC Sensor.
10	.5	BK	Ignition, TDC Sensor.
11	2.5	BK/YL	Start, Start Signal.
12	.75	BU	Charge System, Alternator.
13	.75	BK	Ignition, Ignition Coil.
14	2.5	RD	Charge System, Alternator
15	1.5	GN/YL	Fuel Control, Oxygen Sensor Heater Relay.

# 8500-2 CONNECTOR VIEWS



Mating Face  
ABS HYDRAULIC UNIT

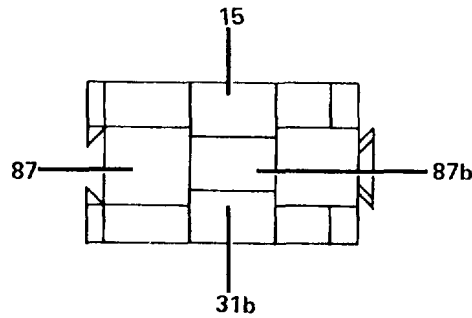

Wiring Face  
A/C COMPRESSOR CONTROL UNIT

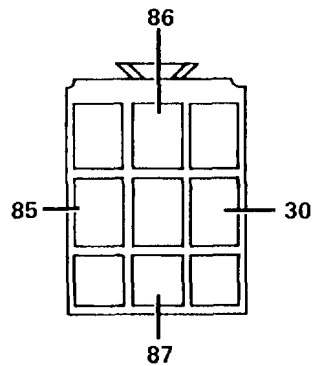

Wiring Face  
A/C COMPRESSOR RELAY



Wiring Face  
A/C CONTROL UNIT (C1)



Wiring Face  
A/C CONTROL UNIT (C2)

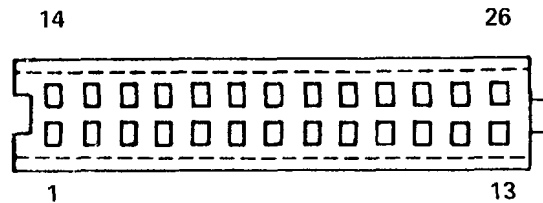

Wiring Face  
ACTIVE CHECK CONTROL UNIT

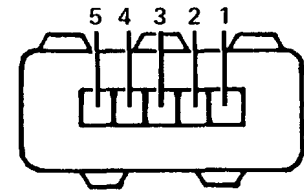

Mating Face  
AIR FLOW METER

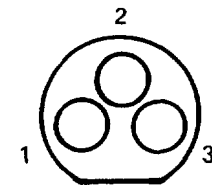

Wiring Face  
AIR INLET TEMPERATURE SENSOR



Wiring Face  
AIR VOLUME/TEMPERATURE SELECTOR

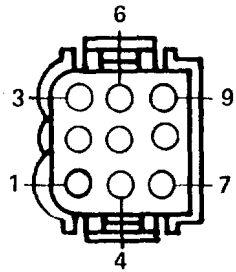

Wiring Face  
AUTOMATIC TRANSMISSION RANGE SWITCH

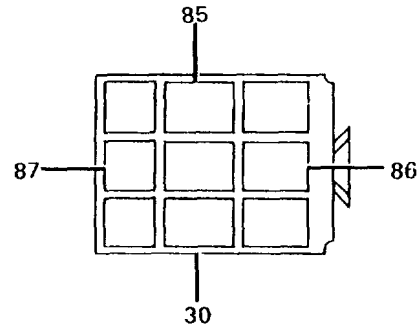

Wiring Face  
BLOWER RELAY

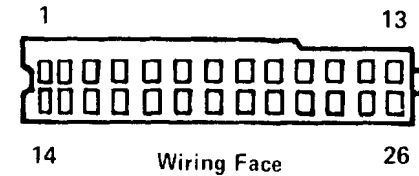

Wiring Face  
CRUISE CONTROL

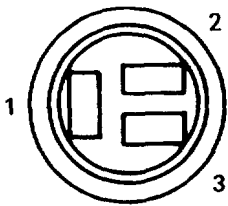

Wiring Face  
AUXILLARY FAN

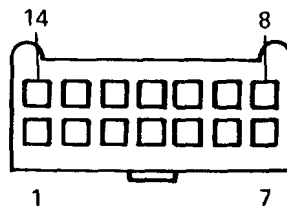

Wiring Face  
CENTRAL LOCKING CONTROL UNIT

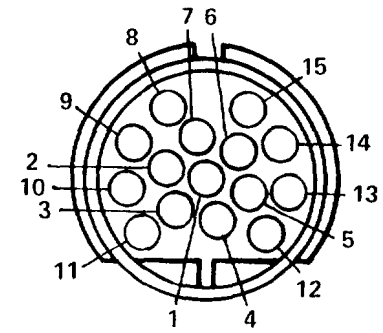

Mating Face  
DIAGNOSTIC CONNECTOR



Wiring Face  
BLOWER FINAL STAGE



Wiring Face  
CHIME MODULE (C1)

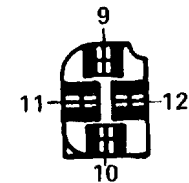

Wiring Face  
DRIVER'S SEAT SWITCH (C1)

# 8500-4 CONNECTOR VIEWS

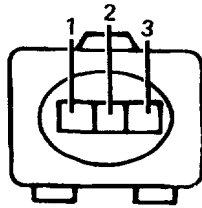

Wiring Face  
ENGINE SPEED SENSOR

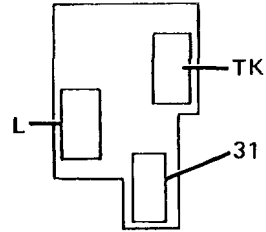

Wiring Face  
FOG LIGHTS/ INTERIOR  
LIGHT SWITCH (C1)

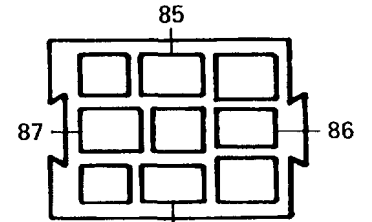

Wiring Face  
FUEL PUMP RELAY

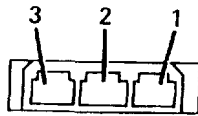

Mating Face  
FADER CONTROL

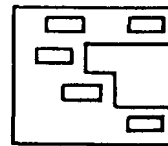

Wiring Face  
FOG LIGHTS/ INTERIOR  
LIGHTS SWITCH (C2)

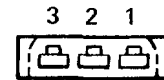

Wiring Face  
FUEL TANK SENDER

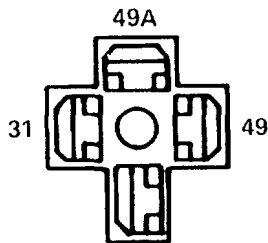

Wiring Face  
FLASHER

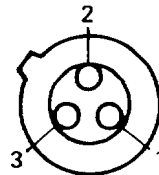

Wiring Face  
FRONT TURN PARK LIGHT



Wiring Face  
FUNCTION SELECTOR

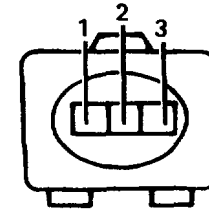

Wiring Face  
IDLE SPEED ACTUATOR

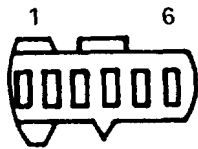

Wiring Face  
GAS FILLER LOCK MOTOR

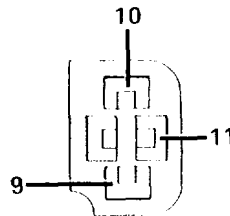

Wiring Face  
HEADREST CONTROL SWITCH



Wiring Face  
IN CAR TEMPERATURE SENSOR/REAR PASSENGER AREA SWITCH

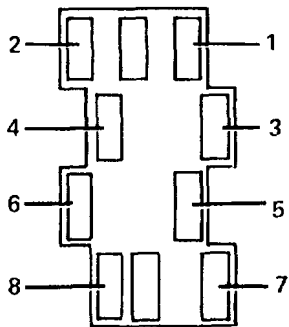

Wiring face  
HAZARD SWITCH

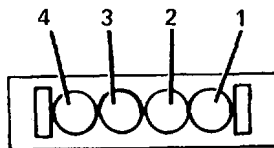

Wiring Face  
HIGH LEVEL STOP LIGHT

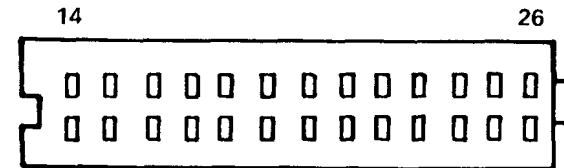

Wiring Face  
INSTRUMENT CLUSTER (C2)

# 8500-6 CONNECTOR VIEWS

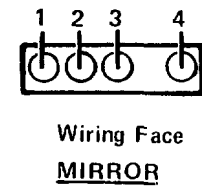
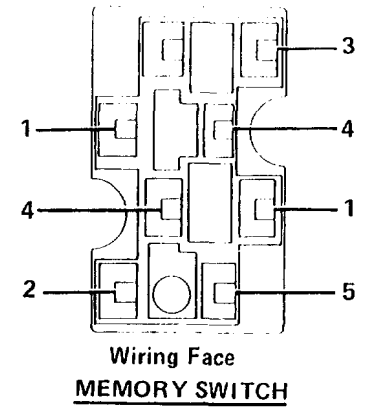
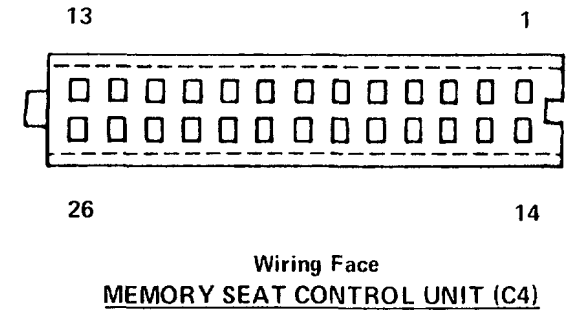
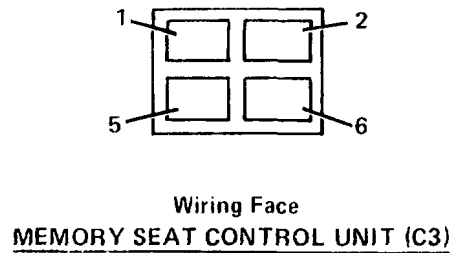
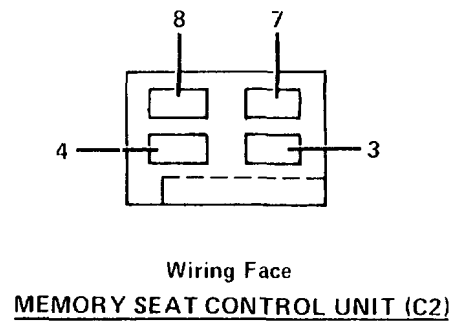
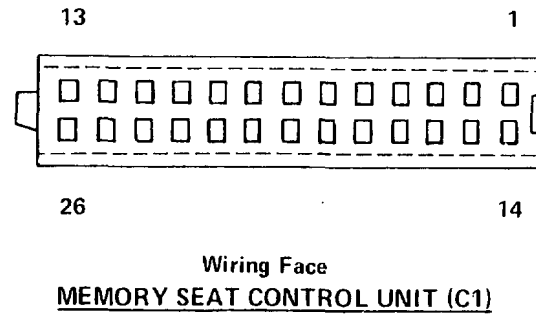
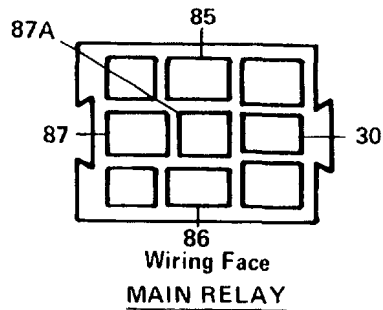
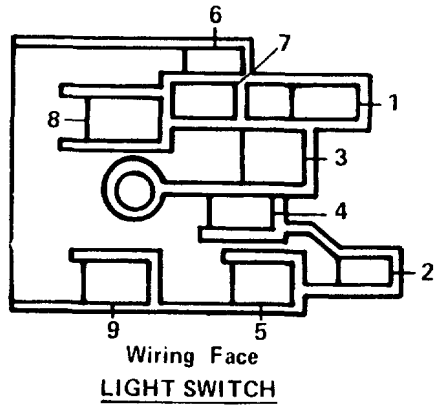
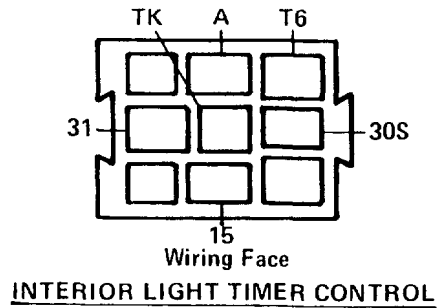



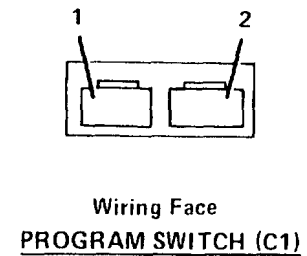
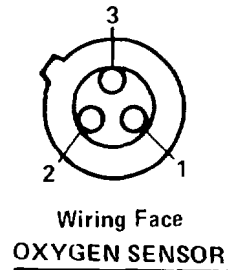
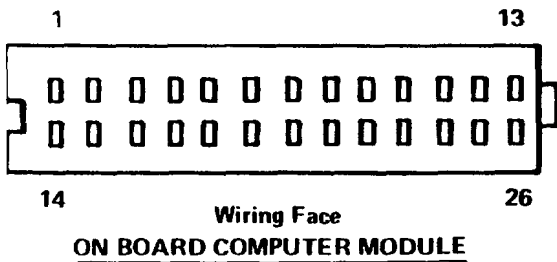
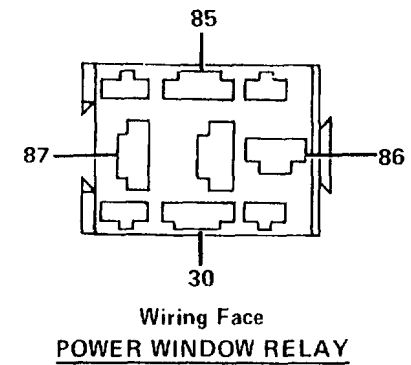
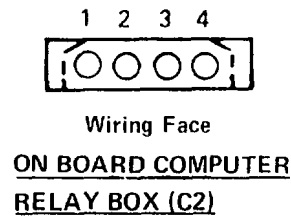
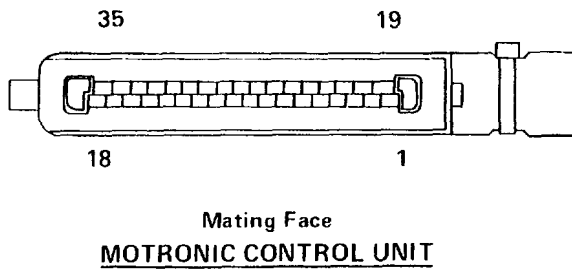
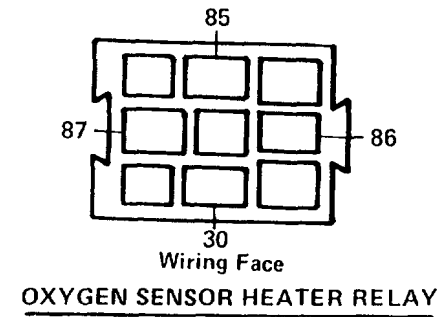
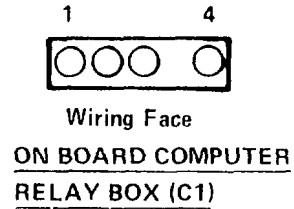
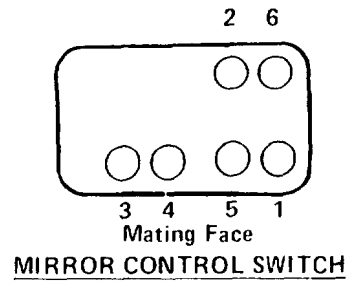

# 8500-8 CONNECTOR VIEWS

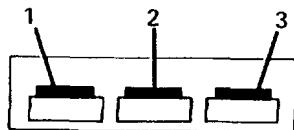

Wiring Face  
PROGRAM SWITCH (C2)

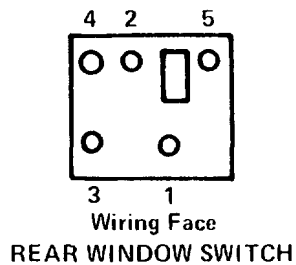

Wiring Face  
REAR WINDOW SWITCH

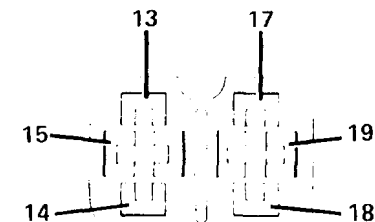

Wiring Face  
SEAT SWITCHES BACK  
& SEAT CUSHIONS

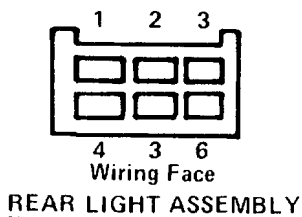

Wiring Face  
REAR LIGHT ASSEMBLY

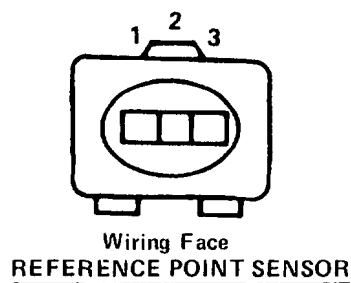

Wiring Face  
REFERENCE POINT SENSOR

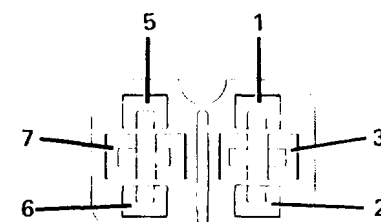

Wiring Face  
SEAT SWITCHES FRONT  
& REAR HEIGHT

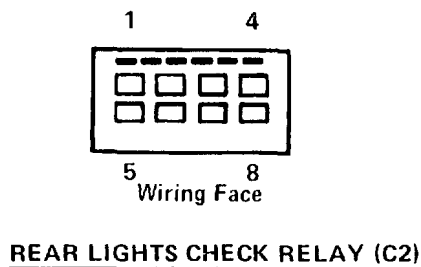

Wiring Face  
REAR LIGHTS CHECK RELAY (C2)

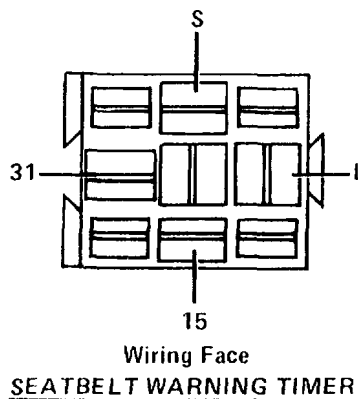

Wiring Face  
SEATBELT WARNING TIMER

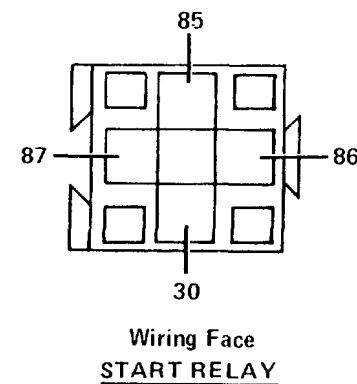

Wiring Face  
START RELAY

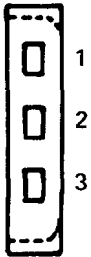

Wiring Face  
SUNROOF MOTOR (CI)

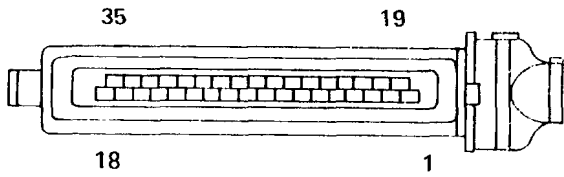

Mating Face  
TRANSMISSION CONTROL UNIT

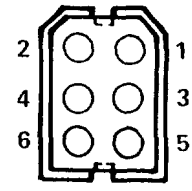

Wiring Face  
WIPER MOTOR

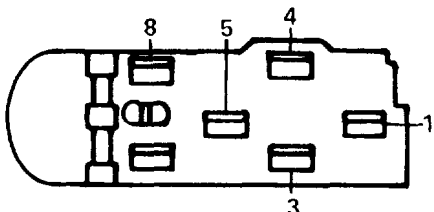

Wiring Face  
SUNROOF SWITCH

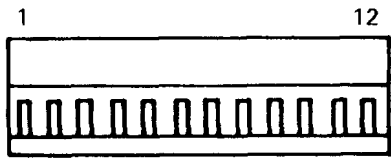

Wiring Face  
TRANSMISSION RANGE DISPLAY

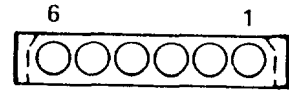

Wiring Face  
WIPER SWITCH

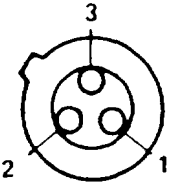

Wiring Face  
THROTTLE POSITION SENSOR

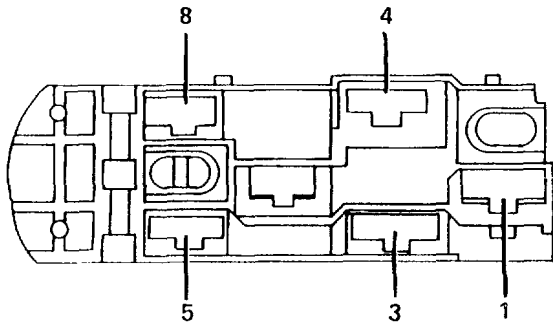

Wiring Face  
WINDOW SWITCHES

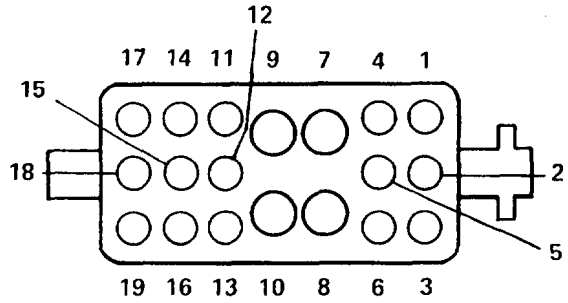

Wiring Face  
C101

# 8500-10 CONNECTOR VIEWS

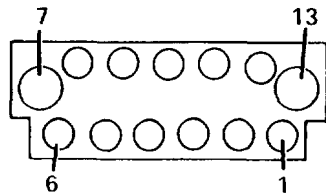

Wiring Face  
C102



Wiring Face  
C114

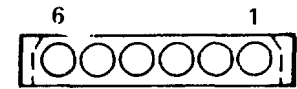

Wiring Face  
C201

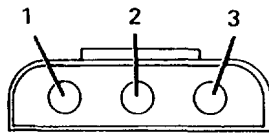

Mating Face  
C103

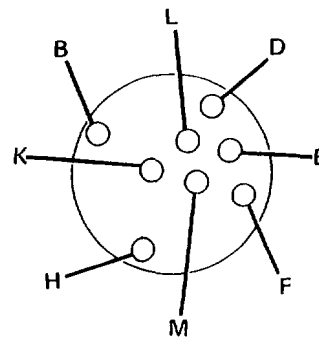

Wiring Face  
C152

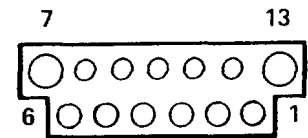

Wiring Face  
C202

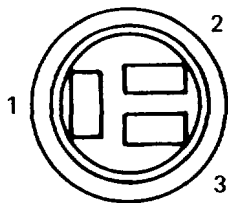

Wiring Face  
C113

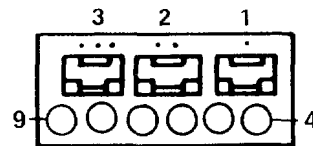

Wiring Face  
C200

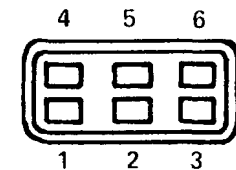

Wiring Face  
C204

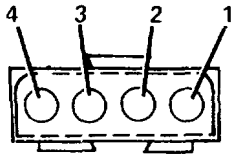

Wiring Face  
C205

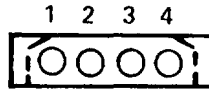

Wiring Face  
C210

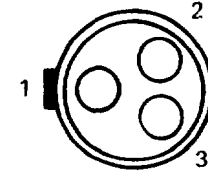

Wiring Face  
C237

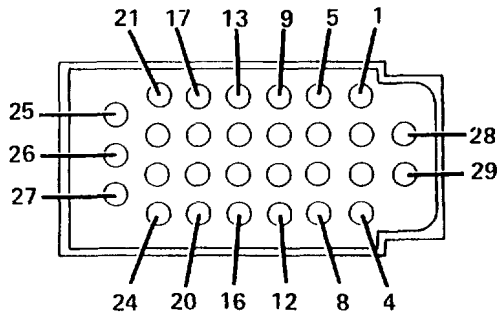

Wiring Face  
C206

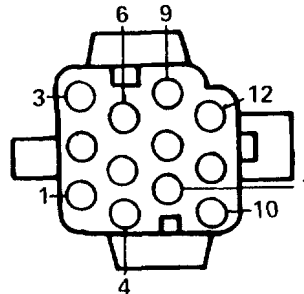

Wiring Face  
C221

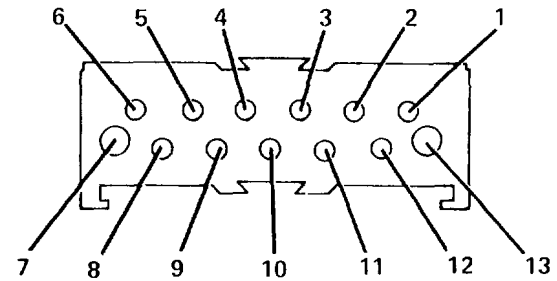

Wiring Face  
C238

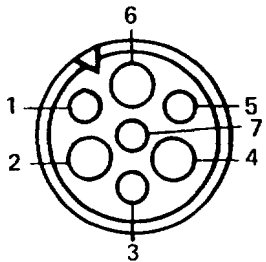

Wiring Face  
C209

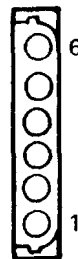

Wiring Face  
C231



Wiring Face  
C240

# 8500-12 CONNECTOR VIEWS

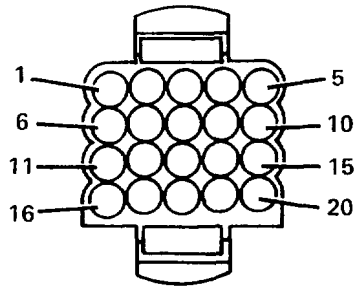

Wiring Face  
C320

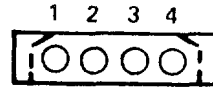

Wiring Face  
C406

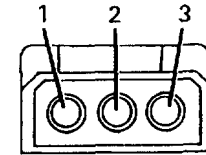

Wiring Face  
C420

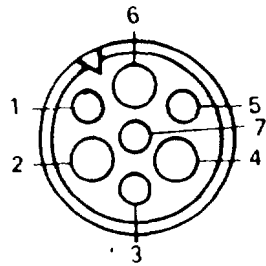

Wiring Face  
C400

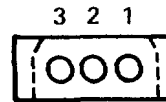

Wiring Face  
C409

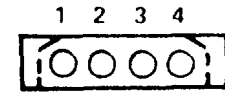

Wiring Face  
C421

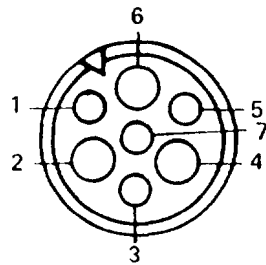

Wiring Face  
C401

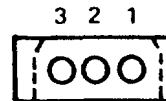

Wiring Face  
C410

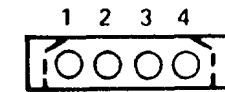

Wiring Face  
C422

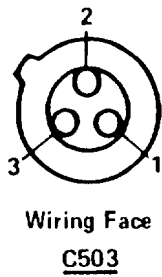
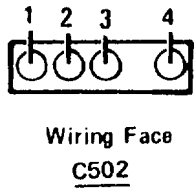
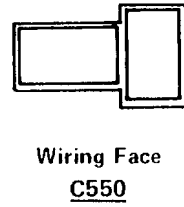
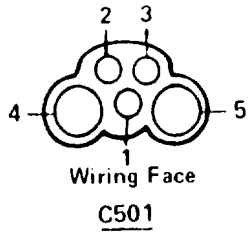

# 9000-0 COMPONENT LOCATION CHART

COMPONENTS		Page-Figure
A/C Control Unit . . . . .	Left side of evaporator housing . . . . .	7000- 1-1
A/C In-Line Fuse . . . . .	Below dash, right of console . . . . .	7000- 6-1
ABS Electronic Control Unit . . . . .	Right side of dash above glove box . . . . .	7000- 3-5
ABS Hydraulic Unit . . . . .	Left side of engine compartment, below battery. . . . .	7000- 7-5
Active Check Control Unit . . . . .	On dash, left of instrument cluster . . . . .	7000- 5-4
Air Bag Gas Generator. . . . .	Top of steering column, in steering wheel . . . . .	7000- 3-4
Air Bag Safety Switch. . . . .	Engine compartment, ahead of left shock tower. . . . .	7000- 4-1
Air Flow Meter . . . . .	Top right of engine . . . . .	7000- 7-2
Air Inlet Temp. Sensor. . . . .	Under center of fresh air intake cowl . . . . .	7000- 2-5
Amplifier . . . . .	Left front of trunk, mounted on underside of rear shelf . . . . .	7000-10-2
Auto. Trans. Range Switch . . . . .	Below console, on base of shift lever . . . . .	7000- 9-5
Automatic Transmission Switch	On left side of shift lever	
Auxiliary Fuel Pump . . . . .	Top left side of fuel tank, under trunk . . . . .	7000- 2-6
B/C Alarm Horn . . . . .	Left front of cowl, below brake fluid reservoir . . . . .	7000- 7-6
B/C Horn Diode . . . . .	Left front of cowl, below brake fluid reservoir . . . . .	7000- 7-6
Backup Light Switch . . . . .	On left side of manual transmission	
Blower Final Stage 1 . . . . .	In right blower fan housing . . . . .	7000- 3-2
Blower Final Stage 2 . . . . .	In left blower fan housing . . . . .	7000- 3-2
Blower Motor . . . . .	Under center of fresh air intake cowl . . . . .	7000- 2-4
Blower Relay . . . . .	Under center of fresh air intake cowl . . . . .	7000- 2-4
Brake Accum. Pres. Switch . . . . .	Right of left front shock tower. . . . .	7000- 5-2
Brake Fluid Level Switch . . . . .	Top left of engine, on brake fluid reservoir. . . . .	7000- 7-3
Brake Switch . . . . .	Above brake pedal	
Central Locking Control Unit . . . . .	Under dash, at LH kick panel. . . . .	7000- 8-6
Chime Module . . . . .	Top center of dash, under grill. . . . .	7000- 9-3
Clutch Switch . . . . .	Above clutch pedal	
Cold Start Valve . . . . .	Left side of engine, between intake ports 3 and 4	
Combination Switch . . . . .	Upper left side of steering column . . . . .	7000- 0-5
Compressor Control Unit . . . . .	Behind dash, left of steering column	
Compressor Relay. . . . .	Under center of fresh air intake cowl . . . . .	7000- 2-4
Coolant Level Switch . . . . .	Top of coolant reservoir	
Coolant Temperature Sender/ Switch . . . . .	Front of engine, on thermostat housing. . . . .	7000- 6-4
Coolant Temperature Sensor . . . . .	Front of engine, top of thermostat housing . . . . .	7000- 6-4
Cruise Control Actuator. . . . .	Left side of engine compartment, by shock tower . . . . .	7000- 7-5
Cruise Control Unit . . . . .	Behind left front speaker . . . . .	7000- 9-4
Defrost Stage 1 Solenoid Valve	Left side of evaporator housing	
Defrost Stage 2 Solenoid Valve	Left side of evaporator housing	



COMPONENTS	Page-Figure
Diagnostic Connector . . . . .	Top middle of engine, on front intake manifold bracket . . . . . 7000- 1-4
Diode Plate . . . . .	Behind front of console
Door Lock Motors . . . . .	In each door
Engine Speed Sensor . . . . .	On lower left side of transmission bell housing
Evaporator Module . . . . .	Behind front of console
Evaporator Sensor . . . . .	Under center of fresh air intake cowl
Evaporator Temp. Switch . . . . .	On support stand for blower motor
Flasher . . . . .	Upper left side of steering column . . . . . 7000- 0-5
Footwell Solenoid Valve . . . . .	Behind center console
Fuel Injectors . . . . .	Base of intake manifold, at each intake port
Fuel Pump Relay . . . . .	Engine compartment, on power distribution box . . . . . 7000- 4-4
Fuel Tank Sender . . . . .	Top left side of fuel tank, under trunk . . . . . 7000- 2-6
Fuel Tank Sender Switch . . . . .	Top left side of fuel tank, under trunk
Gas Filler Lock Motor . . . . .	In trunk, behind left rear wheel well . . . . . 7000- 3-1
Glove Box Light Switch . . . . .	Under right side of dash, on glove box hinge . . . . . 7000- 3-6
High Pressure Cut-Out Switch . . . . .	On receiver-dryer, below washer reservoir . . . . . 7000- 6-2
High Speed Temperature Switch . . . . .	Lower right side of radiator (red terminals) . . . . . 7000- 1-5
Horn Brush/Slip Ring . . . . .	Under hub of steering wheel . . . . . 7000- 3-3
Horn Switches . . . . .	Under hub of steering wheel
Hydraulic Pressure Switch . . . . .	Right of left front shock tower . . . . . 7000- 5-2
Idle Speed Actuator . . . . .	Rear middle of engine compartment . . . . . 7000- 7-4
Ignition Coil . . . . .	On right fender, behind headlights
Ignition Key Switch . . . . .	In upper part of steering column
Ignition Switch . . . . .	Upper part of steering column
In-Car Temp. Sen./Rear Pass. Area . . . . .	Center of dash, in console . . . . . 7000- 1-6
Intensive Washer Pump . . . . .	Ahead of right front wheel well, in reservoir . . . . . 7000- 5-6
Interior Light Timer Control . . . . .	On right side of body electrical connector
Kickdown Switch . . . . .	Below accelerator pedal
Left Fresh Air Stage 1 Solenoid Valve . . . . .	Behind center console
Left Fresh Air Stage 2 Solenoid Valve . . . . .	Left side of evaporator housing
Left Front Crash Sensor . . . . .	Engine compartment, on top of left wheel well . . . . . 7000- 4-1
LH Front Speed Detector . . . . .	In left front wheel
LH Rear Speed Detector . . . . .	In left rear wheel
Lock Heater . . . . .	In left front door

## 9000-2 COMPONENT LOCATION CHART

COMPONENTS		Page-Figure
Lock Heater Control Unit . . . . .	In left front door . . . . .	7000- 0-1
Loop Contact Rings . . . . .	Top of steering column, in bottom of steering wheel.	7000- 3-3
Low Pressure Cut-Out Switch . . . . .	On receiver-dryer, below washer reservoir . . . . .	7000- 6-2
Main Fuel Pump . . . . .	Under car, above left rear axle	
Main Relay . . . . .	Behind right front shock tower . . . . .	7000- 7-1
Memory Seat Control Module . . . . .	Underside of driver's seat	
Motronic Control Unit . . . . .	Behind right front speaker. . . . .	7000- 9-6
Normal Speed Blower Resistor . . . . .	Ahead of radiator, on auxiliary fan shield. . . . .	7000- 8-1
Normal Speed Temperature Switch . . . . .	Lower right side of radiator (white terminals) . . . . .	7000- 1-5
Normal Washer Pump . . . . .	Ahead of right front wheel well in reservoir . . . . .	7000- 5-6
Oil Level Sensor . . . . .	Bottom of engine oil pan	
Oil Pressure Switch. . . . .	Top rear end of cylinder head . . . . .	7000- 7-2
On-Board Computer Module . . . . .	Center of dash, on rear of on-board computer	
On-Board Computer Relay Box . . . . .	Mounted under LH side of dash . . . . .	7000- 8-4
Outside Temperature Sensor . . . . .	Under front bumper, left side . . . . .	7000- 8-2
Oxygen Sensor . . . . .	Underside of car, on exhaust. . . . .	7000- 8-3
Oxygen Sensor Heater Relay . . . . .	Engine compartment, on power distribution box. . . . .	7000- 4-4
Park Brake Switch . . . . .	In shift console, at base of parking brake	
Passenger's Seat Controller . . . . .	Under passenger's seat, on frame	
Power Antenna . . . . .	In RH side of trunk. . . . .	7000-10-3
Power Distribution Box . . . . .	Top front of left front wheel well . . . . .	7000- 4-5
Power Window Circuit Breaker . . . . .	In rear of console	
Power Window Relay . . . . .	Under LH dash, on accessory connector . . . . .	7000- 8-5
Rear Lights Check Relay . . . . .	Under left side of rear seat . . . . .	7000- 0-3
Rear Pass. Area Solenoid Valve. . . . .	Behind center console	
Recirculating Air Solenoid Valve . . . . .	Left side of evaporator housing	
RH Front Speed Detector. . . . .	In right front wheel	
RH Rear Speed Detector . . . . .	In right rear wheel	
Right Fresh Air Solenoid Valve . . . . .	Behind center console	
Right Front Crash Sensor. . . . .	Engine compartment, on top of right wheel well	
Right Front Door Locks Microswitch. . . . .	In right front door	
Seatbelt Switch . . . . .	In driver's seatbelt buckle	
Seatbelt Warning Timer . . . . .	On right side of body electrical connector . . . . .	7000- 8-6
Seat Controllers . . . . .	Under respective seat	
Speedometer Sender. . . . .	In rear of differential	
SRS Diagnostic Module . . . . .	Behind right side of dash, above glove box hinge . . . . .	7000- 3-5
Starter . . . . .	Left rear of engine, below intake manifold	

**COMPONENTS**

		Page-Figure
Start Relay . . . . .	Under LH dash, on body electrical bracket	
Sunroof Motor . . . . .	Above headliner, above rear view mirror . . . . .	7000- 6-6
Sunroof Motor Relay . . . . .	Above headliner, above rear view mirror	
TDC Sensor . . . . .	Above crank shaft vibration damper	
ThermoTime Switch . . . . .	Front of engine, top of thermostat housing . . . . .	7000- 6-4
Throttle Position Sensor . . . . .	Top of engine	
Throttle Switch . . . . .	Top left side of engine, on front of throttle body. . . . .	7000- 0-6
Transmission Control Unit . . . . .	Behind left front speaker . . . . .	7000- 9-4
Trunk Light Switch . . . . .	In trunk lid, near trunk lock	
Trunk Lock Motor . . . . .	In trunk lid, near trunk lock . . . . .	7000-10-1
Underhood Light Switch . . . . .	Under RH rear corner of hood, near latchplate	
Unlock Inhibit Switch . . . . .	In front door handle	
Vacuum Pump . . . . .	Engine compartment, ahead of left front shock tower . . . . .	7000- 5-2
Vent Stage 1 Solenoid Valve . . . . .	Behind center console	
Vent Stage 2 Solenoid Valve . . . . .	Behind center console	
Washer Fluid Level Switch . . . . .	In top of main washer fluid reservoir	
Washer Jet Heaters . . . . .	On washer jet nozzles	
Water Valve Solenoid Valve . . . . .	Right side of evaporator housing	
Window Motors . . . . .	In each door	
Wiper Motor . . . . .	Under left side fresh air intake cowl	

**CONNECTORS**

C101 (17 pin) . . . . .	Engine compartment, on rear of power distribution box . . . . .	7000- 4-5
C102 (13 pin) . . . . .	In power distribution box	
C103 (3 pin) . . . . .	Behind RH kick panel speaker . . . . .	7000- 9-6
C105 (2 pin) . . . . .	Left of glove box hinge	
C106 (1 pin) . . . . .	On hose, above receiver-dryer	
C107 (2 pin) . . . . .	Taped to harness, left of battery	
C109 (1 pin) . . . . .	Engine compartment, right of ignition coil	
C110 (1 pin) . . . . .	Behind right headlights	
C111 (2 pin) . . . . .	Near A/C compressor	
C113 (3 pin) . . . . .	On auxiliary fan shield . . . . .	7000- 8-1
C116 (1 pin) . . . . .	Near lower right side of radiator. . . . .	7000- 1-5
C117 (1 pin) . . . . .	Behind left hand side of battery . . . . .	7000- 4-5
C120 (2 pin) . . . . .	Near wiper motor . . . . .	7000- 7-3
C121 (3 pin) . . . . .	Top center rear of engine . . . . .	7000- 7-4
C122 (3 pin) . . . . .	Top center rear of engine . . . . .	7000- 7-4
C131 (1 pin) . . . . .	Behind right front speaker, near motronic control unit	

## 9000-4 COMPONENT LOCATION CHART

CONNECTORS		Page-Figure
C132 (1 pin)	Behind right front speaker, near motronic control unit	
C141 (3 pin)	Left underside of car, near oxygen sensor	7000- 8-3
C150 (1 pin)	On front of dash behind LH front shock tower	7000- 7-3
C151 (1 pin)	On front of dash behind RH front shock tower	7000- 7-1
C152 (8 pin)	Near transmission	
C200 (10 pin)	Under dash, left of steering column	
C201 (6 pin)	Under dash, on left side of steering column	
C202 (13 pin)	Under dash, on left side of steering column	7000- 8-5
C203 (2 pin)	Upper left side of steering column	7000- 8-5
C204 (6 pin)	Behind center console, left of glove box	7000- 1-2
C205 (1 pin)	Under LH dash, near body electrical bracket	7000- 8-6
C206 (29 pin)	Under left dash, on body electrical bracket	7000- 4-6
C207 (2 pin)	Under LH side of dash near body electrical bracket	7000- 8-4
C209 (7 pin)	Behind left dash, left of accessory connector	7000- 4-6
C210 (4 pin)	Under dash, on left side of steering column	
C211 (1 pin)	Behind instrument cluster	7000- 9-1
C212 (1 pin)	Under left side of dash, behind accessory connector	
C215 (2 pin)	Behind radio	7000- 9-2
C216 (2 pin)	Behind radio	7000- 9-2
C219 (2 pin)	On top of power antenna	7000-10-3
C220 (9 pin)	Behind front of console	
C221 (12 pin)	Below dash, right of console	7000- 1-2
C222 (1 pin)	Under left side of dash, near accessory connector	
C225 (1 pin)	Below steering column	7000- 8-6
C226 (4 pin)	Behind front of console	
C227 (1 pin)	Behind Function Selector	
C230 (13 pin)	Underside of front passenger seat	
C235 (1 pin)	Under left side of dash, near steering column	
C237 (3 pin)	Taped in harness, behind brake fluid reservoir	7000- 7-3
C238 (13 pin)	Behind right front speaker	7000- 9-6
C240 (6 pin)	Behind right side of dash, above glove box hinge	7000- 3-6
C243 (1 pin)	Behind front of console	
C250 (2 pin)	Behind right side of dash, above glove box hinge	7000- 3-6
C251 (1 pin)	Behind front of console	
C252 (1 pin)	Behind front of console	
C253 (1 pin)	Behind front of console	
C254 (1 pin)	Behind center console	
C260 (2 pin)	Above steering column lower trim panel	7000- 3-3
C270 (4 pin)	Behind right side of dash, above glove box hinge	7000- 3-6

**CONNECTORS**

Page-Figure

C300 (1 pin)	Ahead of left trunk hinge, left of shock tower	7000- 2-3
C301 (2 pin)	In center console, ahead of shift lever	7000- 9-5
C302 (Accessory Connector)	Under left dash, on body electrical bracket	7000- 4-6
C303 (2 pin)	In headliner, above left dome light	7000- 2-2
C304 (7 pin)	Ahead of left trunk hinge, left of shock tower	7000- 2-3
C305 (2 pin)	Near left tail light assembly	
C306 (2 pin)	Near right tail light assembly	
C308 (2 pin)	Near right tail light assembly	
C309 (2 pin)	At LH rear pillar	
C310 (2 pin)	At RH rear pillar	
C320 (20 pin)	Left front of trunk, near hinge	7000-10-2
C350 (1 pin)	At connector bracket under LH side of dash	7000- 8-4
C351 (1 pin)	Under right side of rear seat	7000- 0-4
C352 (1 pin)	Under left side of rear seat	7000- 0-3
C400 (7 pin)	Under left dash, near body electrical bracket	
C401 (7 pin)	Under right side of dash, right of glove box	7000- 1-3
C402 (2 pin)	In left center pillar	
C403 (2 pin)	In right center pillar	
C404 (1 pin)	In left center pillar	
C405 (1 pin)	In right center pillar	
C406 (3 pin)	Behind center console	
C407 (2 pin)	Under right side of dash, right of glove box	7000- 1-3
C408 (2 pin)	To left of body electrical bracket	
C409 (3 pin)	In right center pillar	
C410 (3 pin)	In left center pillar	
C420 (3 pin)	Below front of console	7000- 9-5
C421 (4 pin)	Below front of driver's seat	
C422 (4 pin)	Below front of passenger's seat	
C423 (2 pin)	Underside of driver's seat	
C424 (4 pin)	Below front of driver's seat	
C425 (4 pin)	Underside of driver's seat	
C426 (6 pin)	Underside of driver's seat	
C428 (3 pin)	Underside of driver's seat	
C429 (3 pin)	Underside of driver's seat	
C501 (5 pin)	Under dash, left of steering column	7000- 4-6
C502 (5 pin)	Under right side of dash, right of glove box	7000- 1-3
C503 (8 pin)	In driver's door	
C504 (2 pin)	Under dash, above trunk release lever	7000- 4-6
C550 (2 pin)	Below front of console	7000- 9-5
C560 (2 pin)	In driver's door	

## 9000-6 COMPONENT LOCATION CHART

---

### GROUNDS

G103 (Engine Ground) . . . . .	Top rear of engine, left of valve cover . . . . .	7000- 7-2
G104 (Main Body Ground) . . . . .	On power distribution box bracket . . . . .	7000- 4-5
G200 (Front Interior Ground) . . . . .	On dash frame, left of steering column	
G201 (Column Ground) . . . . .	Top of steering column . . . . .	7000- 0-5
G202 . . . . .	Above glove box, forward of ABS control unit . . . . .	7000- 3-5
G203 . . . . .	Behind center of dash, to right of radio . . . . .	7000- 9-2
G301 (Rear Interior Ground) . . . . .	Under left side of rear seat . . . . .	7000- 0-3
G302 . . . . .	In trunk, on rear panel center support . . . . .	7000-10-1
G303 . . . . .	Below rear of console	
G305 . . . . .	In RH C pillar	
G307 . . . . .	In trunk, below power antenna motor . . . . .	7000- 6-5
G400 . . . . .	Behind right side of dash, above glove box hinge . . . . .	7000- 3-5
G600 . . . . .	Above headliner, above rear view mirror	

---