



---

**1986**

---

**BMW 635CSi**

---

**Electrical**

---

**Troubleshooting**

---

**Manual**

---

BMW of North America, Inc.  
Montvale, New Jersey

## FOREWORD

In the interests of continuing technical development work we reserve the right to modify designs and equipment.

Printed in USA

©Copyright BMW of North America, Inc.

Not to be reproduced wholly or in part  
without written permission of BMW of  
North America, Inc.

PN 01 00 1 467 813

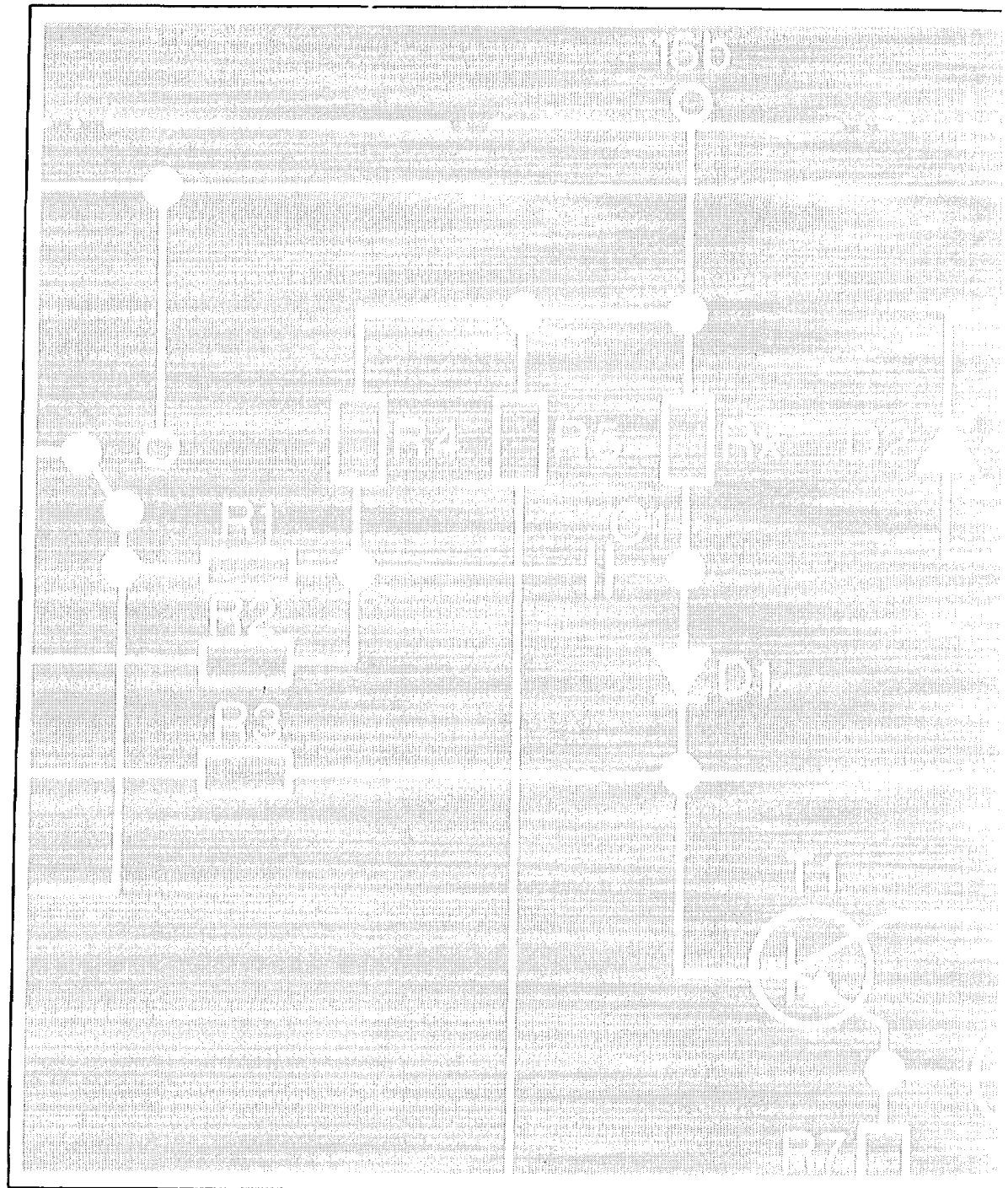

**1986  
BMW 635CSi  
Electrical  
Troubleshooting  
Manual**

**CONTENTS**

---

Index .....	2
How To Use This Manual .....	3
Symbols .....	4
Wire Size Conversion Chart ...	5
Systematic Troubleshooting ..	6
Connector Views .....	8500-0
Power Distribution Box .....	0670-0
Fuse Data .....	0670-1
Component Location Chart ...	9000-0
Component Location Views ..	7000-0
Splice Location Views .....	8000-0

---

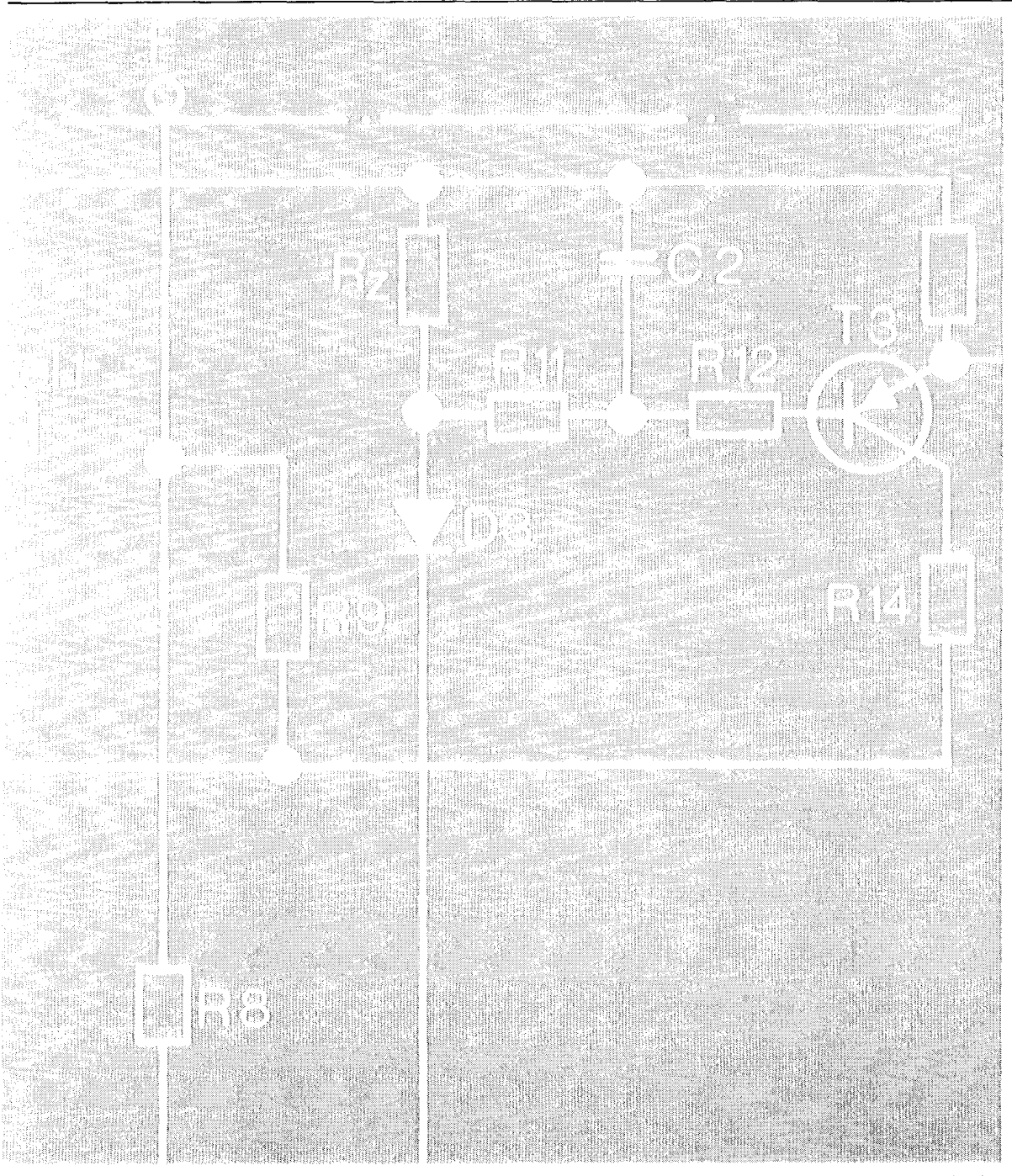

## 2 INDEX

### Index — Alphabetical Listing of Electrical Circuits

	PAGE		PAGE		PAGE
Active Check Control . . . . .	6216- 0	— G103 . . . . .	0670-11	— Fog . . . . .	6312- 0
AntiLock Braking System . . . . .	3450- 0	— G104 . . . . .	0670-11,13,15	— Front Park. . . . .	6314- 0
A/C Auxiliary Evaporator . . . . .	6414- 0	— G200 . . . . .	0670-12,13	— Glove Box . . . . .	6100- 2
A/C Blower Control . . . . .	6413- 0	— G201 . . . . .	0670-12	— Hazard . . . . .	6313- 0
A/C Compressor Control . . . . .	6411- 0	— G302 . . . . .	0670-14	— Headlights . . . . .	6312- 0
A/C Panel Lights . . . . .	6400- 0	Heated Door Lock . . . . .	6100- 0	— Interior . . . . .	6330- 0
A/C Temperature Control . . . . .	6411- 0	Horn . . . . .	6100- 0	— License . . . . .	6320- 0
Auto-Charging Flashlight . . . . .	6100- 2	Idle Speed Control		— Rear Marker . . . . .	6320- 0
Auxiliary Fan . . . . .	6454- 0	— Electronic Transmission . . . . .	1360- 1	— Stop . . . . .	6325- 0
Body Electrical . . . . .	6100- 0	— Manual Transmission . . . . .	1360- 5	— Tail . . . . .	6314- 0
Brake Lining Warning . . . . .	3435- 0	Ignition		— Transmission Range . . . . .	6300- 1
Central Locking . . . . .	5126- 0	— Electronic Transmission . . . . .	1360- 2	— Turn . . . . .	6313- 1
Charging System . . . . .	1230- 0	— Manual Transmission . . . . .	1360- 3	— Trunk . . . . .	6320- 0
Cigar Lighter . . . . .	6100- 2	Ignition Key Warning . . . . .	6131- 0	— Underhood . . . . .	6314- 0
Component Location Views . . . . .	7000- 0	Indicators		— Visor . . . . .	6300- 0
Connector Views . . . . .	8500- 0	— Active Check Control Alarm. . . . .	6210- 1	Light Switch Details . . . . .	6300- 2
Cruise Control . . . . .	6571- 0	— "Brake Lights" Fault . . . . .	6216- 1	Memory Seat . . . . .	5200- 0
Electronic Transmission Control . . . . .	2460- 0	— "Brake Lining" Wear . . . . .	3435- 0	On-Board Computer . . . . .	6581- 0
Engine Block Diagrams . . . . .	1250- 0	— "Brake" Warning . . . . .	6210- 2	Power Antenna . . . . .	6500- 0
Fuel Control		— "Charge" Indicator . . . . .	6210- 0	Power Distribution . . . . .	0670- 2
— Electronic Transmission . . . . .	1360- 0	— "Coolant" Level Fault. . . . .	6216- 3	Power Distribution Box . . . . .	0670- 0
— Manual Transmission . . . . .	1360- 4	— "Engine Oil" Fault . . . . .	6216- 3	Power Mirrors . . . . .	5116- 0
Fuel Delivery		— Fasten Seatbelts . . . . .	6216- 3	Power Seats . . . . .	5200- 0
— Electronic Transmission . . . . .	1360- 0	— Fog Lights . . . . .	6210- 2	Power Windows . . . . .	5133- 0
— Manual Transmission . . . . .	1360- 0	— High Beam . . . . .	6210- 2	Radio . . . . .	6500- 0
Fuel Gauge . . . . .	6210- 1	— Inspection . . . . .	6210- 3	Rear Defogger . . . . .	6100- 1
Fuse Data . . . . .	0670- 1	— LH Turn . . . . .	6210- 2	Seat Belt Warning . . . . .	6131- 0
Fuse Details		— "License Plate" Fault . . . . .	6216- 2	Seat Bolster Support . . . . .	5200- 5
— Fuse 5 . . . . .	0670- 6	— "Low Beam" Fault . . . . .	6216- 0	Speedometer . . . . .	6210- 0
— Fuse 6 . . . . .	0670- 9	— Low Fuel Warning . . . . .	6210- 1	Start	
— Fuse 9 . . . . .	0670- 8	— Oil Pressure Warning . . . . .	6210- 1	— Electronic Transmission . . . . .	1240- 0
— Fuse 10 . . . . .	0670- 7	— Oil Service . . . . .	6210- 3	— Manual Transmission . . . . .	1240- 1
— Fuse 12 . . . . .	0670- 6	— "Park Brake" . . . . .	6210- 1	Splice Location Views . . . . .	8000- 0
— Fuse 19 . . . . .	0670- 8	— "Rear Lights" Fault . . . . .	6216- 2	Sunroof . . . . .	5413- 0
— Fuse 20 . . . . .	0670- 9	— RH Turn . . . . .	6210- 2	Tach/Fuel Economy Gauge . . . . .	6210- 0
— Fuse 21 . . . . .	0670-10	— Temperature Warning . . . . .	6210- 1	Temperature Gauge . . . . .	6210- 1
— Fuse 26 . . . . .	0670- 7	— "Washer Fluid" Fault . . . . .	6216- 3	Warning Indicators . . . . .	6210- 0
— Fuse 27 . . . . .	0670- 7	Injection Electronics . . . . .	1360- 0	Windshield Washer Jet Heaters . . . . .	6160- 1
Gauges . . . . .	6210- 0	Instrument Cluster . . . . .	6210- 0	Wiper/Washer . . . . .	6160- 0
Ground Distribution		Lights			
G101 . . . . .	0670-15	— Backup . . . . .	6322- 0		
		— Dash . . . . .	6300- 1		

The purpose of this manual is to show electrical schematics in a manner that makes electrical troubleshooting easier. Electrical components which work together are shown together on one schematic. The Wiper-Washer schematic, for example, shows all of the electrical components in one diagram. At the top of the page is the fuse (positive) that powers the circuit. The flow of current is shown through all wires, connectors, switches, and motors to ground (negative) at the bottom of the page.

Within the schematic, all switches and sensors are shown "at rest," as though the Ignition Switch were off. For identification, component names are underlined and placed next to or above each component. Notes are included, describing how switches and other components work.

The power distribution schematic shows the current feed through all the connections from the Battery and Alternator to each fuse and the Ignition and Light Switches. If the Power Distribution schematic is combined with any other circuit schematic, a complete picture is made of how that circuit works. The Ground Distribution schematics show how several circuits are connected to common grounds.

All wiring between components is shown exactly as it exists in the vehicle; however, the wiring is not drawn to scale. To aid in understanding electrical operation, wiring inside complicated components has been simplified. The "Solid State" label designates electronic components.

WIRE SIZE CONVERSION CHART	
METRIC (CROSSSECTIONAL AREA IN MM <sup>2</sup> )	AWG (AMERICAN WIRE GAUGE)
.5	20
.75	18
1	16
1.5	14
2	14
2.5	12
4	10
6	8
8	8
16	4
20	4
25	2
32	2

WIRE INSULATION	
ABBREVIATIONS	COLOR
BK	BLACK
BR	BROWN
RD	RED
YL	YELLOW
GN	GREEN
BU	BLUE
VI	VIOLET
GY	GRAY
WT	WHITE
PK	PINK

# 4 SYMBOLS



ENTIRE COMPONENT SHOWN



PART OF A COMPONENT SHOWN

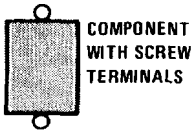

COMPONENT WITH SCREW TERMINALS

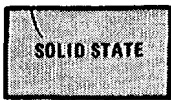

SOLID STATE (INCLUDES ONLY ELECTRONIC PARTS)

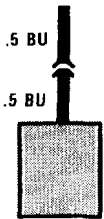

CONNECTOR ON COMPONENT LEAD (PIGTAIL)

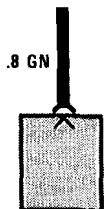

CONNECTOR ATTACHED TO COMPONENT

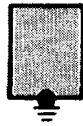

COMPONENT CASE IS DIRECTLY ATTACHED TO METAL PART OF CAR (GROUNDED)

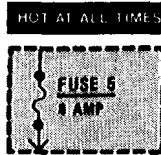

INDICATES THAT FUSE 5 IS ALWAYS SUPPLIED WITH POWER

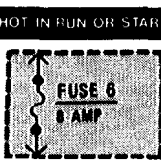

INDICATES THAT FUSE 6 IS SUPPLIED WITH POWER WITH THE IGNITION SWITCH IN THE RUN OR START POSITIONS

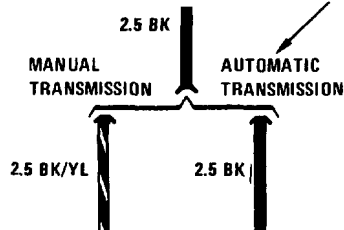

WIRE CHOICES FOR OPTIONS ARE SHOWN AND LABELED

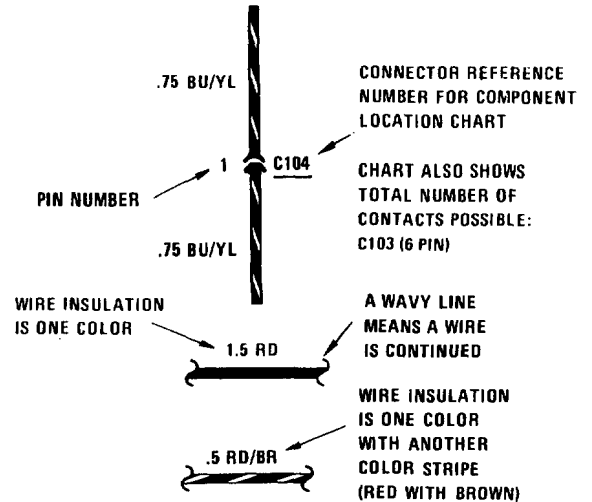

CONNECTOR REFERENCE NUMBER FOR COMPONENT LOCATION CHART

CHART ALSO SHOWS TOTAL NUMBER OF CONTACTS POSSIBLE: C103 (6 PIN)

WIRE INSULATION IS ONE COLOR

A WAVY LINE MEANS A WIRE IS CONTINUED

WIRE INSULATION IS ONE COLOR WITH ANOTHER COLOR STRIPE (RED WITH BROWN)

WIRE SIZE IN MM<sup>2</sup>

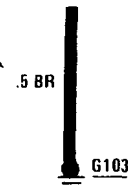

WIRE IS ATTACHED TO METAL PART OF CAR (GROUNDED) GROUND IS NUMBERED FOR REFERENCE ON COMPONENT LOCATION CHART

OTHER CIRCUITS THAT SHARE A GROUND ARE SHOWN IN GROUND DISTRIBUTION

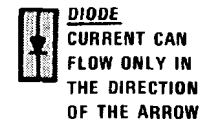

DIODE CURRENT CAN FLOW ONLY IN THE DIRECTION OF THE ARROW

CIRCUIT REFERENCE - A WIRE WHICH CONNECTS TO ANOTHER CIRCUIT



ACTIVE CHECK CONTROL

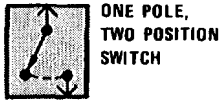

**ONE POLE,  
TWO POSITION  
SWITCH**

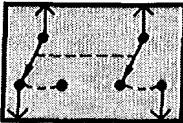

**SWITCHES THAT  
MOVE TOGETHER**  
  
DASHED LINE SHOWS  
A MECHANICAL  
CONNECTION  
BETWEEN SWITCHES

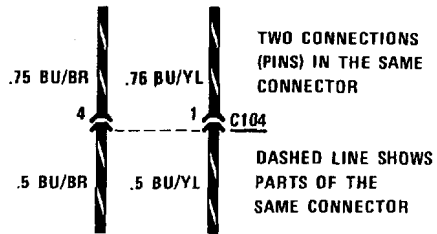

**TWO CONNECTIONS  
(PINS) IN THE SAME  
CONNECTOR**  
  
DASHED LINE SHOWS  
PARTS OF THE  
SAME CONNECTOR

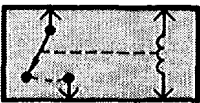

**WHEN COIL IS  
ENERGIZED, SWITCH  
IS PULLED CLOSED**

**RELAY SHOWN  
WITH NO  
CURRENT  
FLOWING  
THROUGH  
COIL**

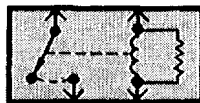

**RESISTOR ACROSS COIL  
IS FOR NOISE  
SUPPRESSION**

**RELAY SHOWN  
WITH RESISTOR  
ACROSS COIL**

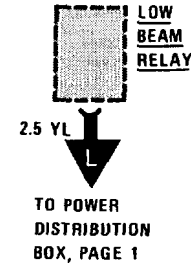
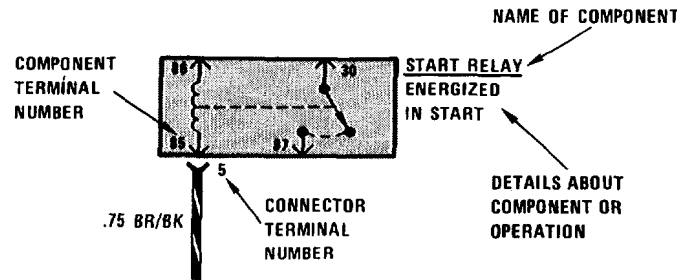

**CURRENT PATH  
IS CONTINUED  
AS LABELED.  
THE ARROW SHOWS  
DIRECTION OF CURRENT  
FLOW AND IS REPEATED  
WHERE CURRENT  
PATH CONTINUES.**

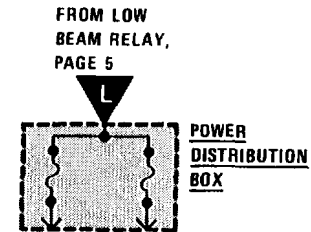
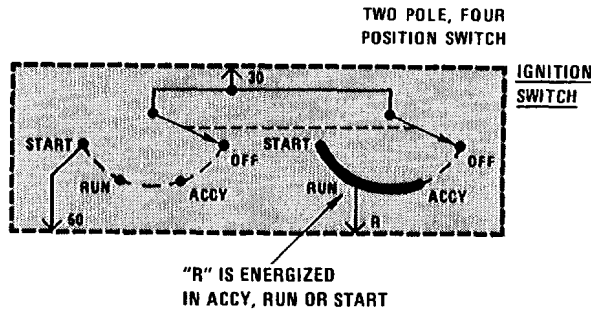

**LIGHT  
EMITTING  
DIODE**

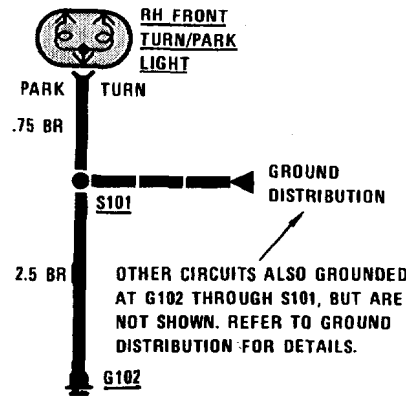

## 6 SYSTEMATIC TROUBLESHOOTING

### TROUBLESHOOTING PROCEDURE

#### 1. Verify the Problem

Operate the problem circuit to check the accuracy of the complaint. Note the symptoms of the inoperative circuit.

#### 2. Analyze the Problem

Refer to the schematic of the problem circuit in the ETM. Determine how the circuit is supposed to work by tracing the current path(s) from the power feed through the circuit components to ground. Then based on the symptoms you noted in step 1 and your understanding of circuit operation, identify one or more possible causes of the problem.

#### 3. Isolate the Problem

Make circuit tests to prove or disprove the preliminary diagnosis made in step 2. Keep in mind that a logical simple procedure is the key to efficient troubleshooting. Test for the most likely cause of failure first. Try to make tests at points which are easily accessible.

#### 4. Repair the Problem

Once the specific problem is identified, make the repair using the proper tools and safe procedures.

#### 5. Check the Problem

Operate the circuit to check for satisfactory circuit operation. Good repair practice calls for rechecking all circuits you have worked on.

### TROUBLESHOOTING TOOLS

Isolating the problem (Step 3 of TROUBLESHOOTING PROCEDURES) requires the use of a **voltmeter** and/or **ohmmeter**. A voltmeter measures voltage at selected points in a circuit. An ohmmeter measures a circuit's resistance to current flow. It has an internal battery that provides current to the circuit under test. Disconnect the car battery when using an ohmmeter because the battery voltage will cause the ohmmeter to give false readings. Also, do not use an ohmmeter on solid-state components. The voltage that the ohmmeter applies to the circuit could damage these components.

### TROUBLESHOOTING TESTS

#### Voltage Test

This test measures voltage in a circuit. By taking measurements at several points (terminals or connectors) along the circuit, you can isolate the problem.

To take a voltage measurement, connect the negative lead of the voltmeter to the battery's negative terminal or other known good ground. Then connect the positive lead of the voltmeter to the point you want to test. The voltmeter will measure the voltage present at that point in the circuit.

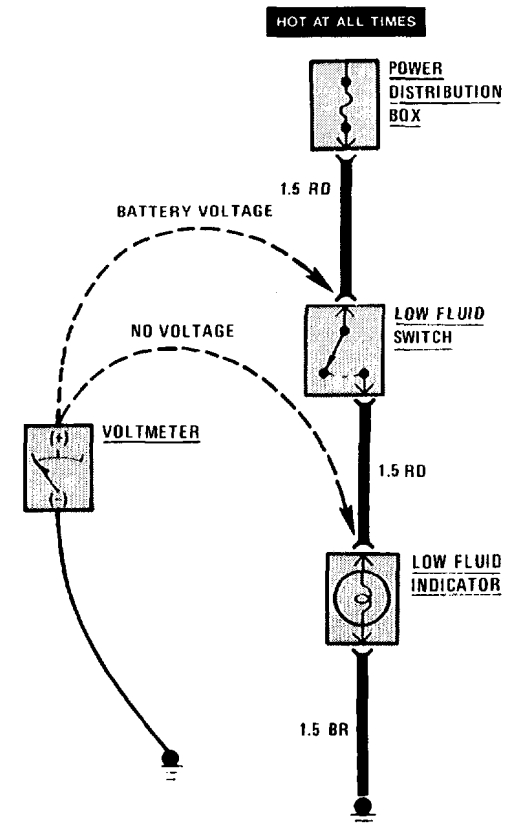

Voltage Test



Voltage Drop Test

Wires, connectors, and switches are designed to conduct current with a minimum loss of voltage. A voltage drop of more than one volt indicates a problem.

To test for voltage drop, connect the voltmeter leads to connectors at either end of the circuit's suspected problem area. The positive lead should be connected to the connector closest to the power source. The voltmeter will show the voltage drop between these two points.

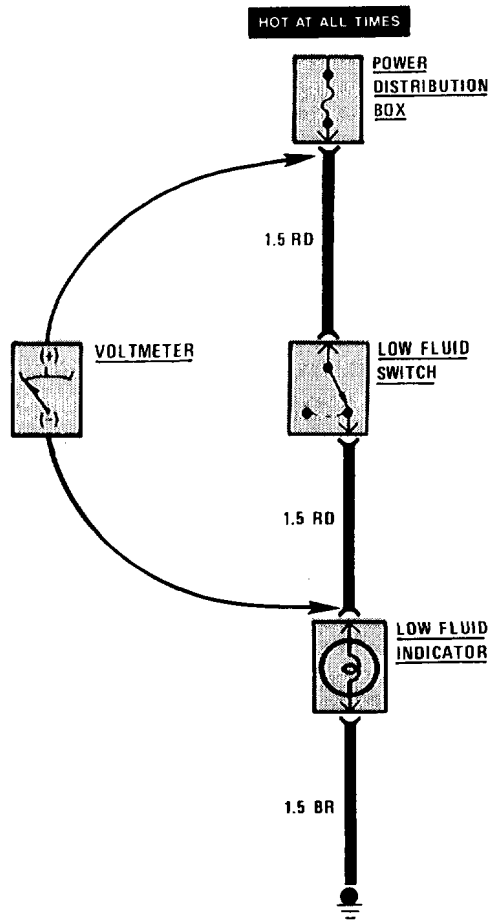

Voltage Drop Test

Continuity Test

To perform a continuity test, first disconnect the car battery. Then adjust the ohmmeter to read zero while holding the leads together. Connect the ohmmeter leads to connector or terminals at either end of the circuit's suspected problem area. The ohmmeter will show the resistance across that part of the circuit.

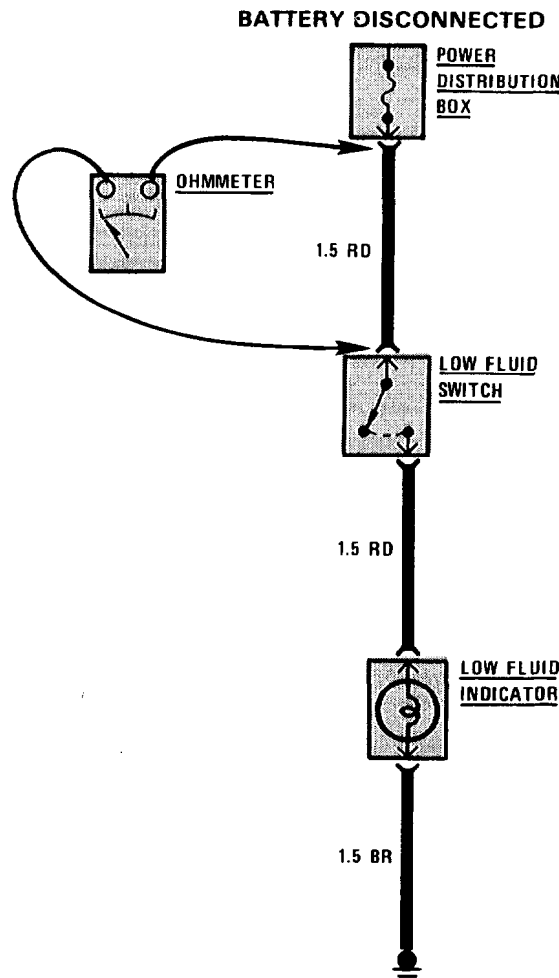

Continuity Test

Short Test Using Voltmeter

Remove the blown fuse and disconnect the load. Connect the voltmeter leads to the fuse terminals. The positive lead should be connected to the terminal closest to the power source.

Starting near the POWER DISTRIBUTION BOX, move the wire harness back and forth and watch the voltmeter reading. If the voltmeter registers a reading, there is a short to ground in the wiring. Somewhere in the area of the harness being moved, the wire insulation is worn away and the circuit is grounding.

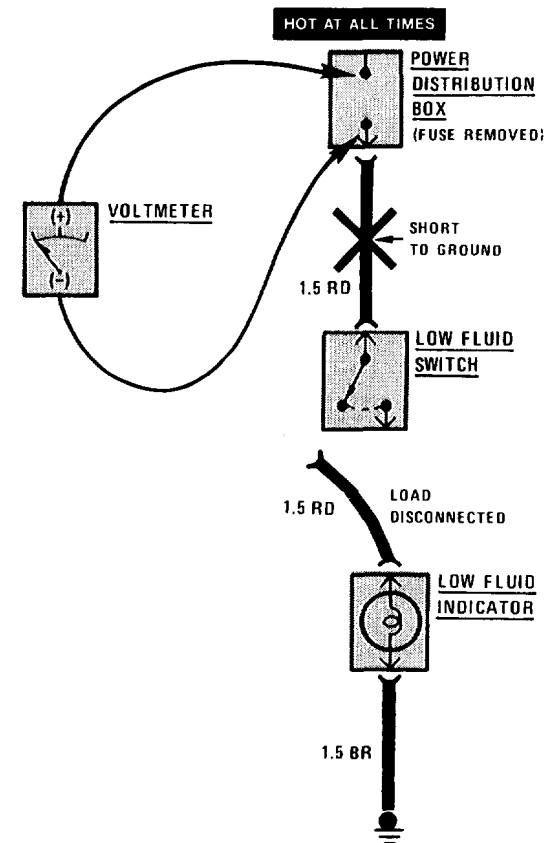

Short Test Using Voltmeter

## 8 SYSTEMATIC TROUBLESHOOTING

### Short Test Using Ohmmeter

Disconnect the battery. Adjust the ohmmeter to read zero while holding the leads together. Remove the blown fuse and disconnect the load. Connect one lead of the ohmmeter to the fuse terminal that is closest to the load. Connect the other lead to a known good ground.

Starting near the POWER DISTRIBUTION BOX, move the wire harness back and forth and watch the ohmmeter reading. Low or no resistance indicates a short to ground in the wiring. Infinitely high resistance indicates no short.

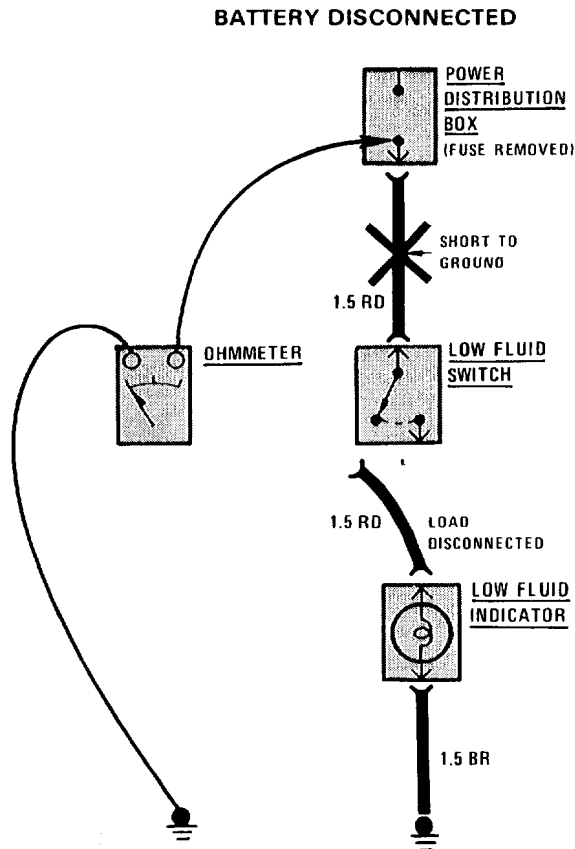

Short Test Using Ohmmeter

# 0670-0 POWER DISTRIBUTION

## POWER DISTRIBUTION BOX

### NOTE

On some cars, the position of the Fuel Pump and Purge Valve Relays may be the opposite of what is shown. Check relay wire colors for positive identification.

MAIN RELAY

DIAGNOSTIC CONNECTOR

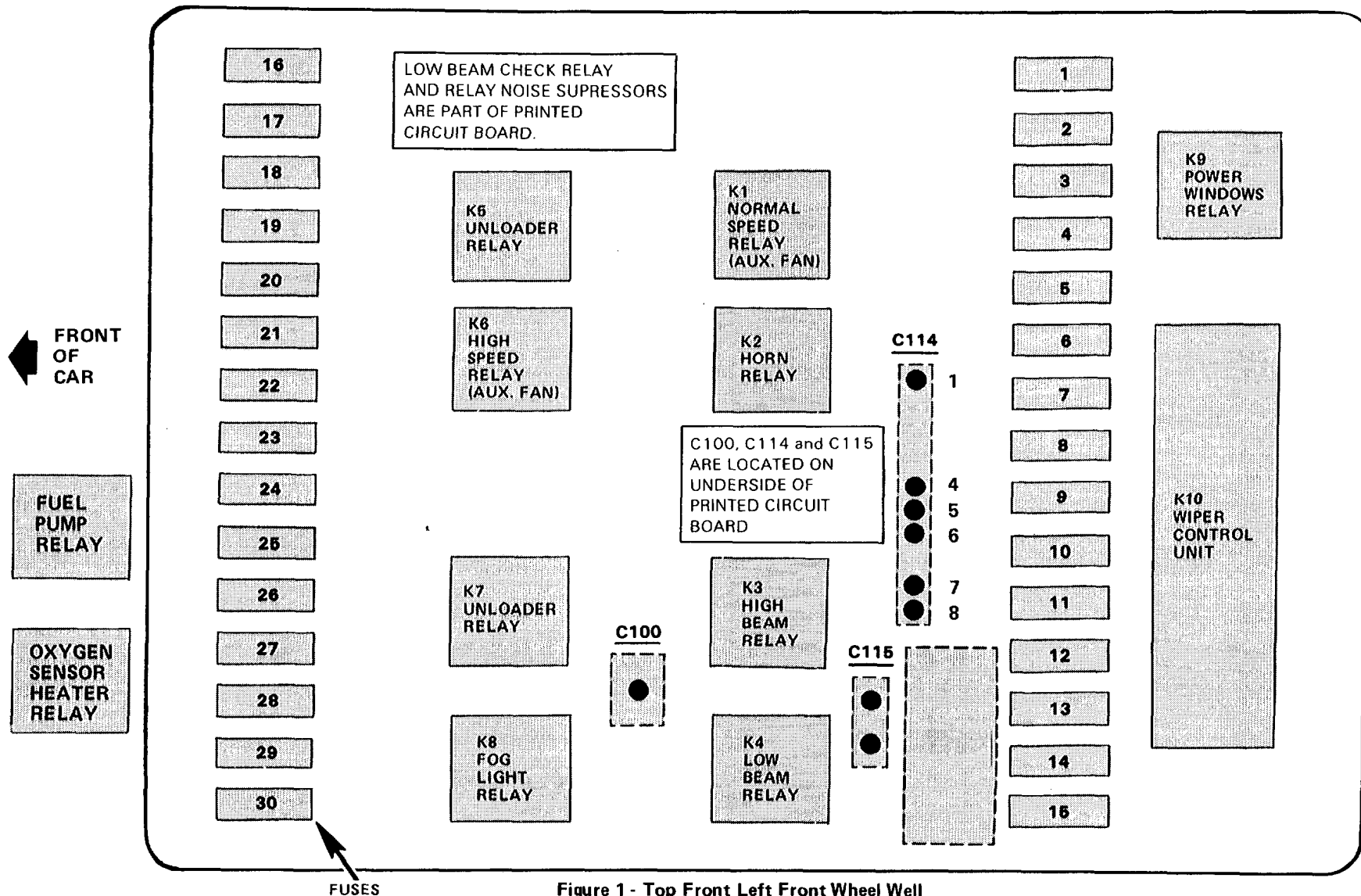

Figure 1 - Top Front Left Front Wheel Well

**FUSE DATA CHART**

FUSE NO.	SIZE/ COLOR	CIRCUIT PROTECTED
1	7.5A (BR)	Headlights (also fuses 2, 13, 14).
2	7.5A (BR)	Headlights (also fuses 1, 13, 14).
3	30A (LT GN)	Auxiliary Fan.
4	15A (LT BU)	Lights: Turn/Hazard Warning (also fuse 24).
5	30A (LT GN)	Wiper/Washer. Windshield Washer Jet Heater.
6	7.5A (BR)	Active Check Control (also fuse 10, 12, 21, 22, 23); Cruise Control (also fuse 17); Stoplights.
7	15A (LT BU)	Horn.
8		Not Used.
9	7.5A (BR)	Idle Speed Control (also fuse 17); Back Up Lights.
10	7.5A (BR)	Active Check Control (also fuses 6, 12, 21, 22, 23); On-Board Computer (also fuses 12, 21, 27); Speedometer/Gauges/Warning Indicators (also fuse 21); Brake Lining Warning; Service Interval Indicator (also fuse 21); Seatbelt Warning; Auxiliary Fan.
11	15A (LT BU)	Fuel Delivery.
12	7.5A (BR)	Active Check Control (also fuse 6, 10, 21, 22, 23); On-Board Computer (also fuses 10, 21, 27); Radio (also fuses 21, 28. Radio In-Line Fuse); Warning Indicators.
13	7.5A (BR)	Headlights (also fuses 1, 2, 14)
14	7.5A (BR)	Headlights (also fuses 1, 2, 13).
15		Not Used.
16	30A (LT GN)	Heating/Air Conditioning.
17	30A (LT GN)	Auxiliary Fan; Back Up Lights; Cruise Control (also fuse 6); Lights: Dash/ Transmission Range (also fuse 23); Heater/Air Conditioning; Interior Lights (also fuse 21); Power Mirrors; Seatbelt Warning.
18	30A (LT GN)	Auxiliary Fan.
19	30A (LT GN)	Sunroof.

FUSE NO.	SIZE/ COLOR	CIRCUIT PROTECTED
20	30 (LT GN)	Rear Defogger (also fuse 23).
21	7.5A (BR)	Active Check Control (also fuses 6, 10, 12, 22, 23); Auto-Charging Flashlight; Gauges (also fuse 12); Glove Box Light; Interior Lights (also fuse 17); On-Board Computer (also fuses 12, 27); Radio (also fuses 12, 28. Radio In-Line Fuse); Service Interval Indicator (also fuse 10); Trunk Light.
22	7.5A (BR)	Active Check Control (also fuses 6, 10, 12, 21, 23); Lights: Front Park/Rail (also fuse 20).
23	7.5A (BR)	Active Check Control (also fuses 6, 10, 12, 21, 22); Rear Defogger (also fuse 20); Lights: Front Park/Tail/Underhood (also fuse 22); Heater/Air Conditioning; Lights: Dash/Transmission Range/RH Visor (also fuse 17) Lights: Rear Marker/License.
24	15A (LT BU)	Lights: Turn/Hazard Warning (also fuse 4).
25	25 A (WT)	Not Used
26	30A (LT GN)	Power Seats
27	30A (LT GN)	Central Locking; Heated Door Lock; On-Board Computer (also fuses 10, 21, 22).
28	30A (LT GN)	Cigar Lighter; Power Antenna (also fuses 12, 21. Radio In-Line Fuse).
29	7.5A (BR)	Fog Lights (also fuse 30).
30	7.5A (BR)	Fog Lights (also fuse 29).
Power Window Circuit Breaker	25	Power Windows.

# 0670-2 POWER DISTRIBUTION

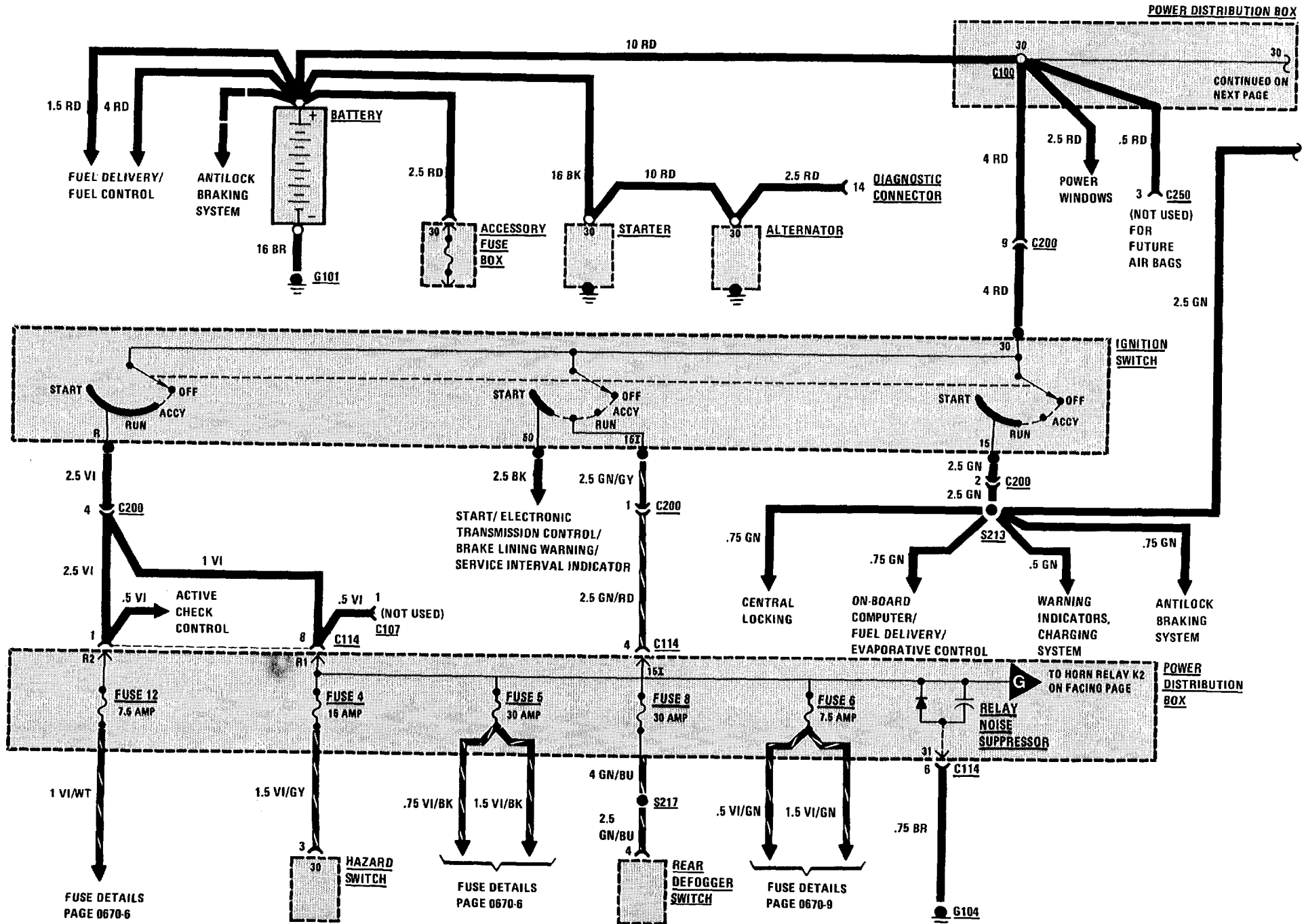

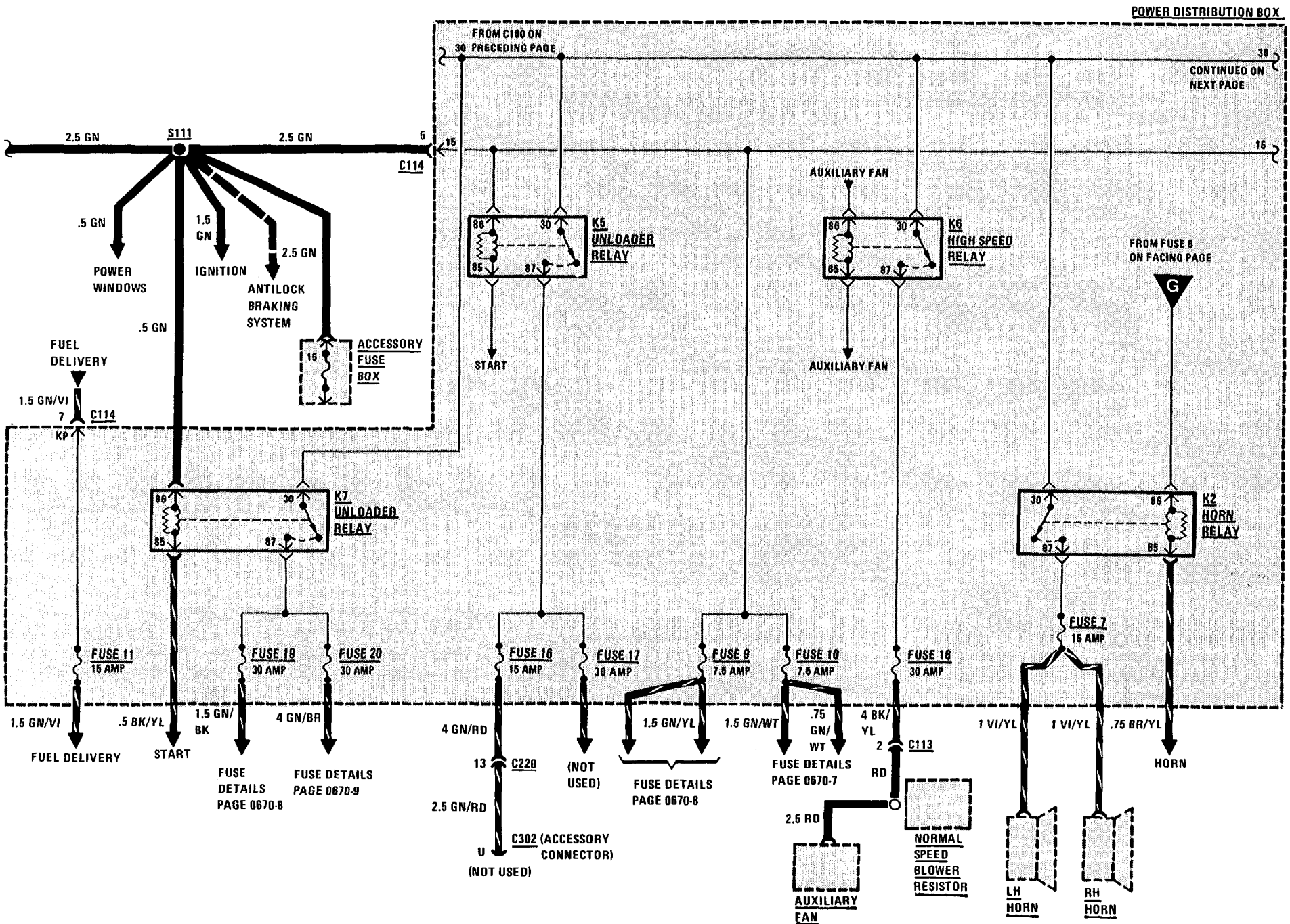

# 0670-4 POWER DISTRIBUTION

POWER DISTRIBUTION BOX

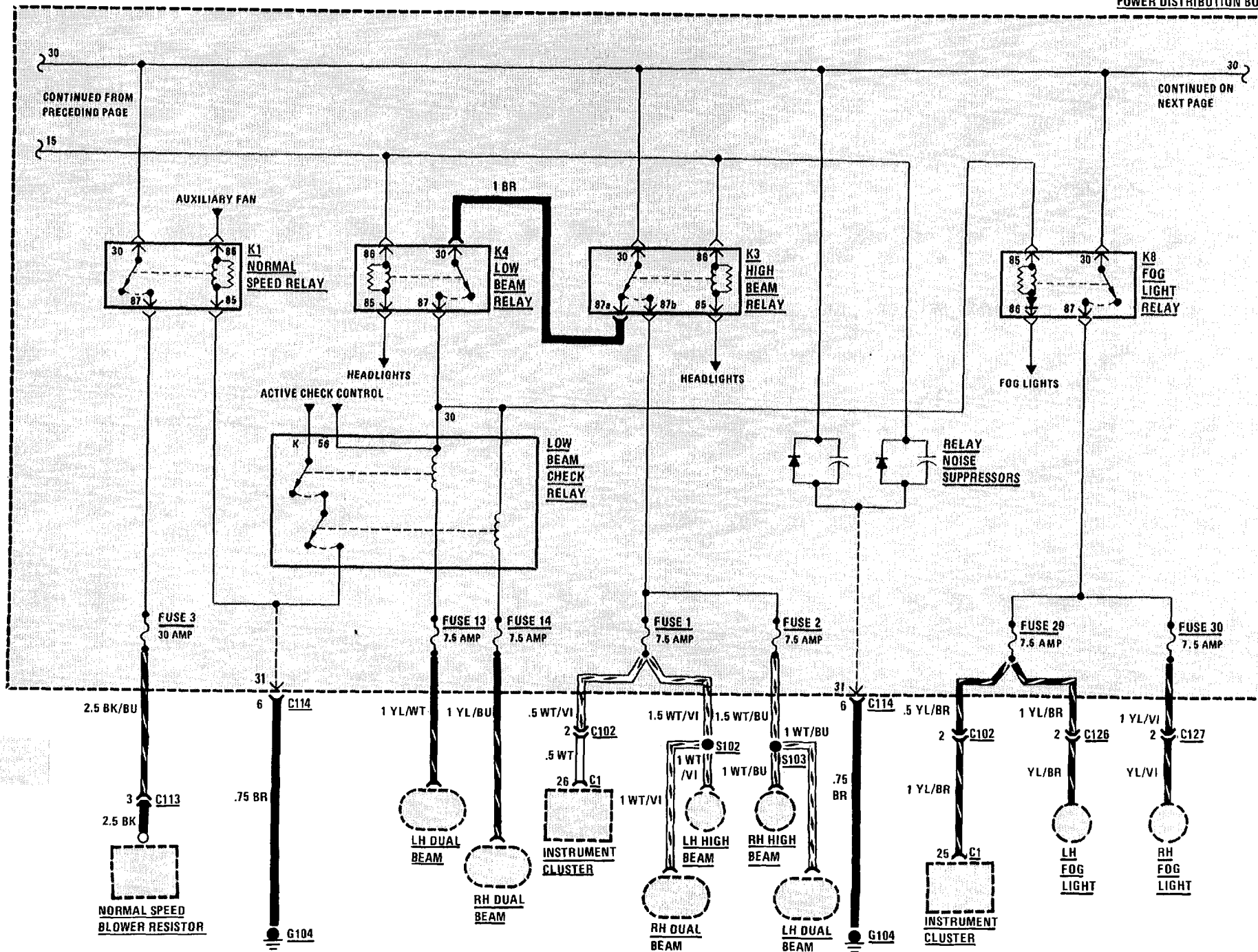

# POWER DISTRIBUTION 0670-5

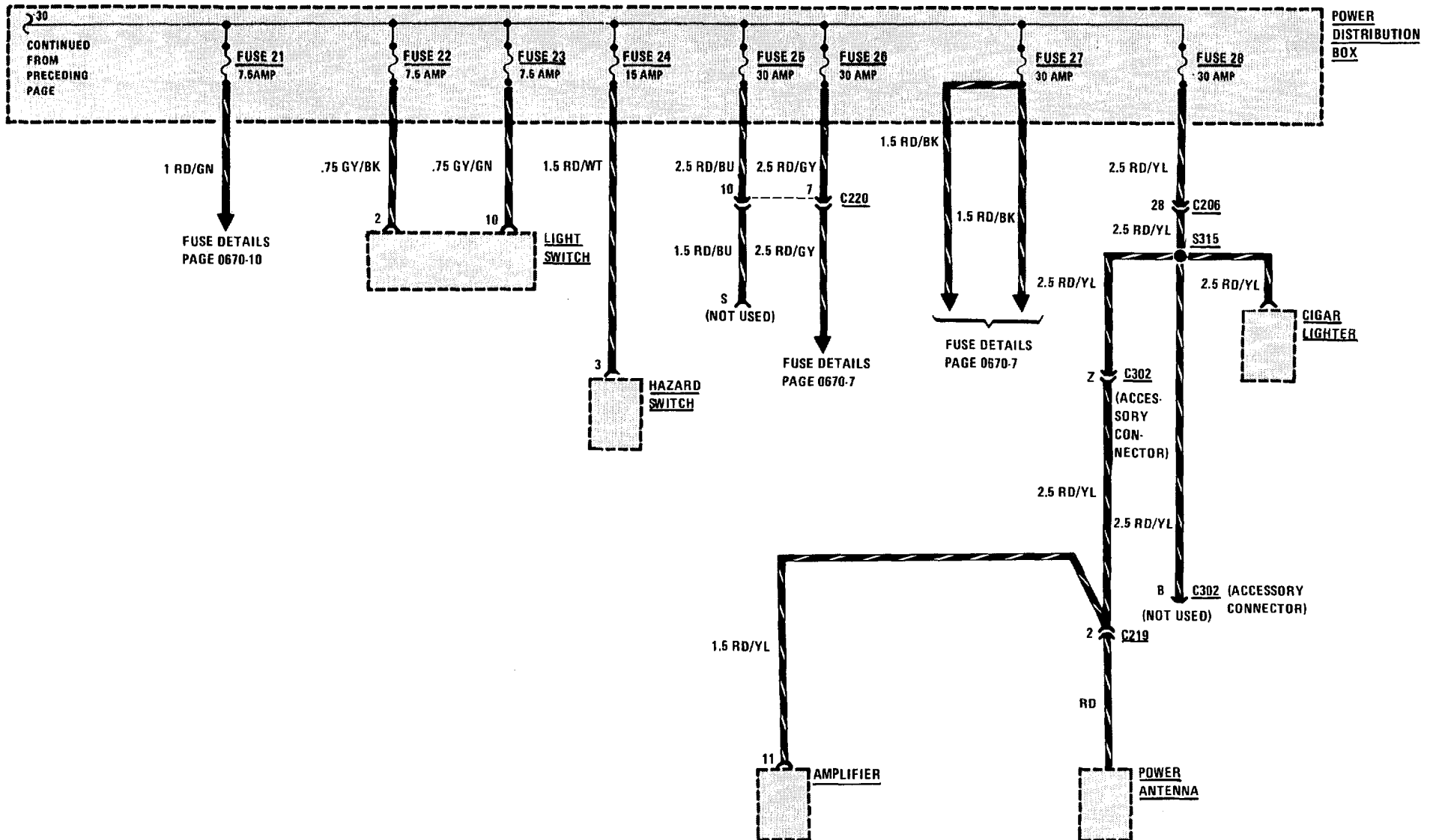



FUSE DETAILS: FUSES 12 AND 5

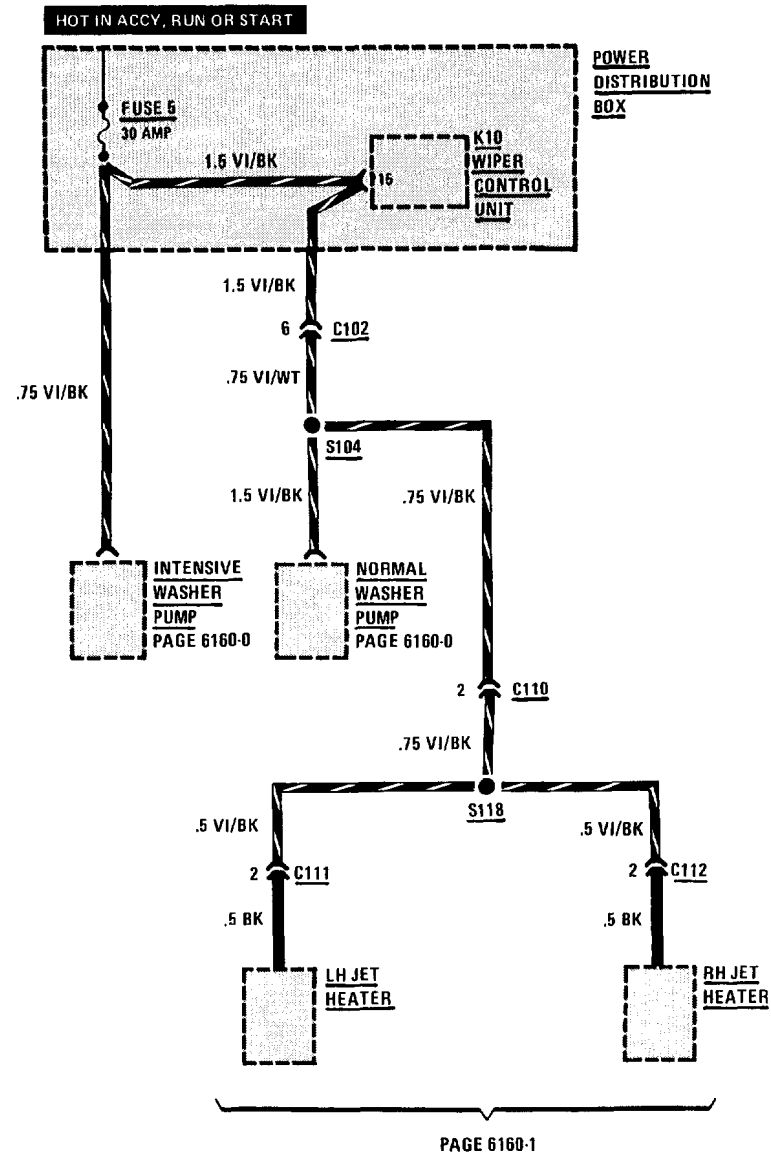
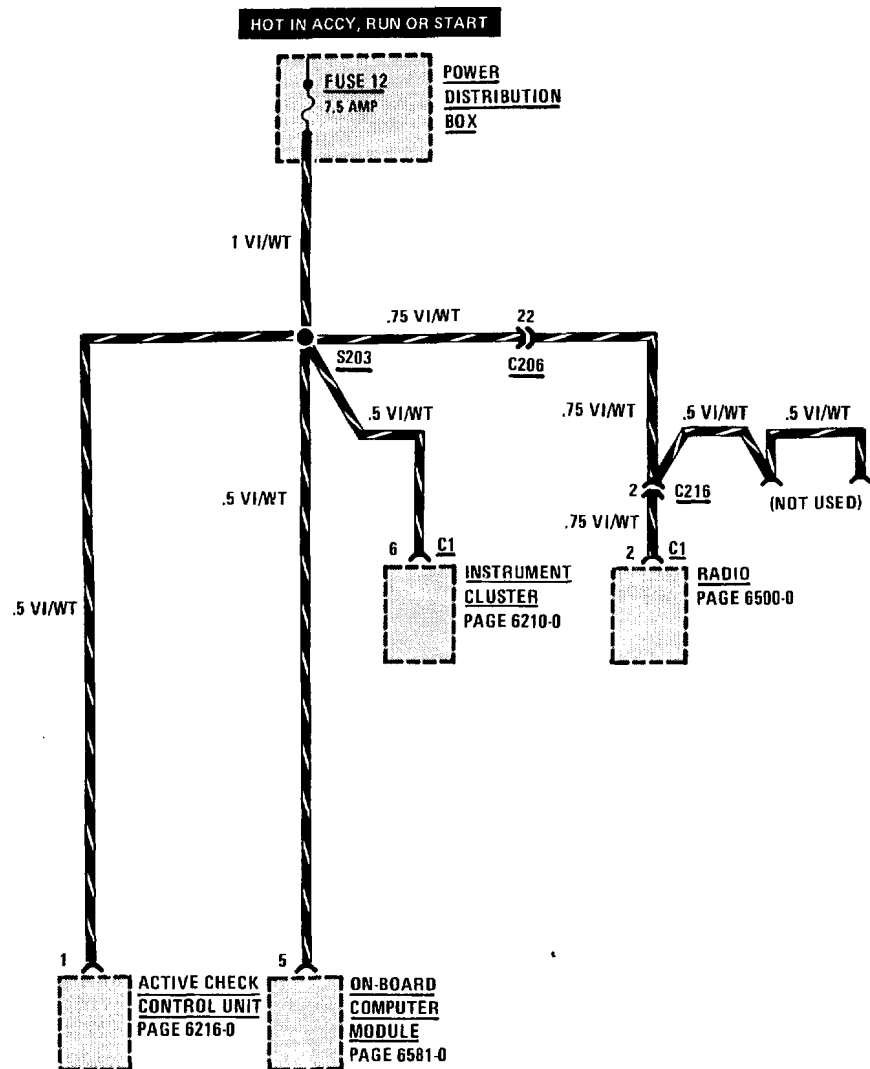

FUSE DETAILS: FUSES 10, 26 AND 27

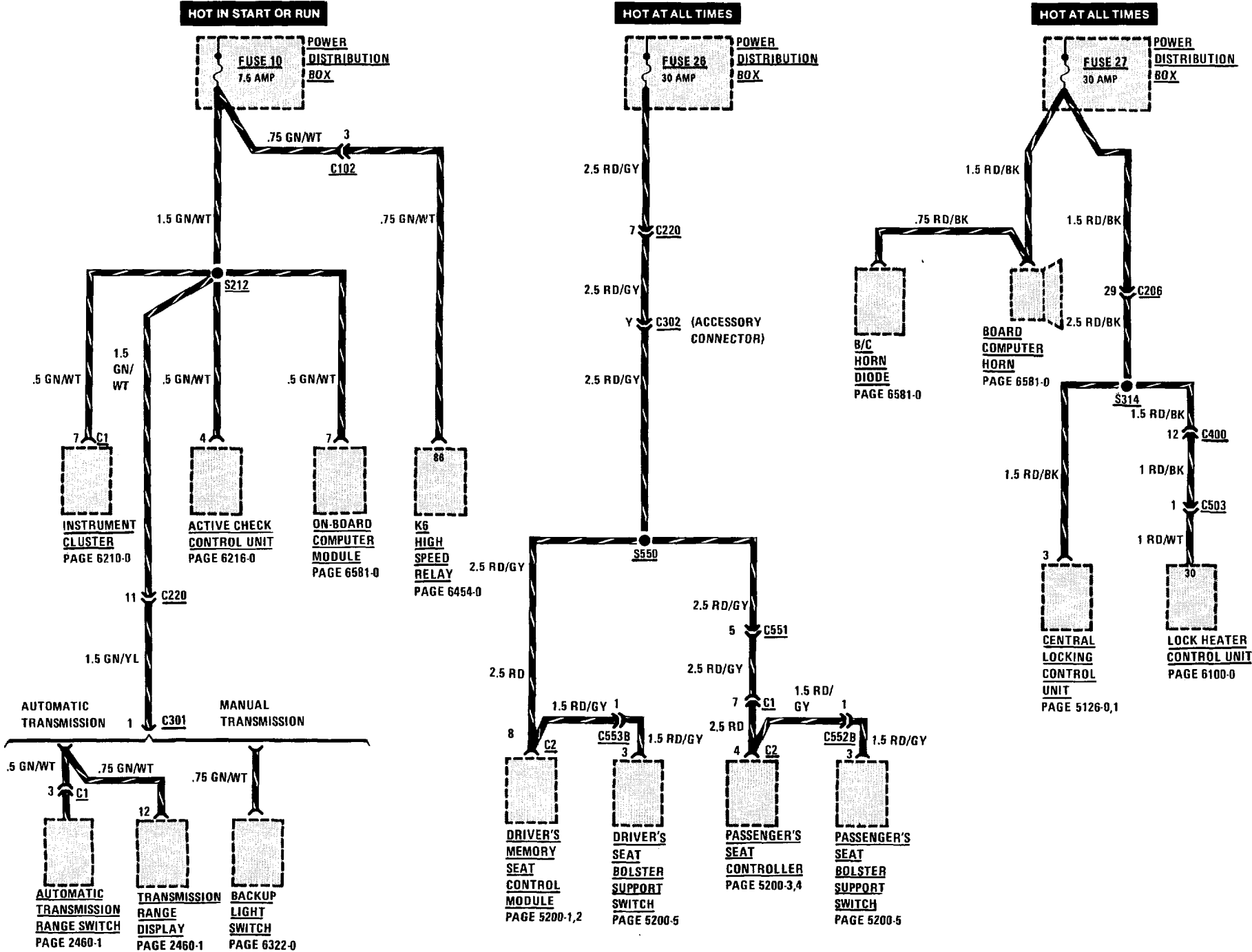

# 0670-8 POWER DISTRIBUTION

## FUSE DETAILS: FUSES 9 AND 19

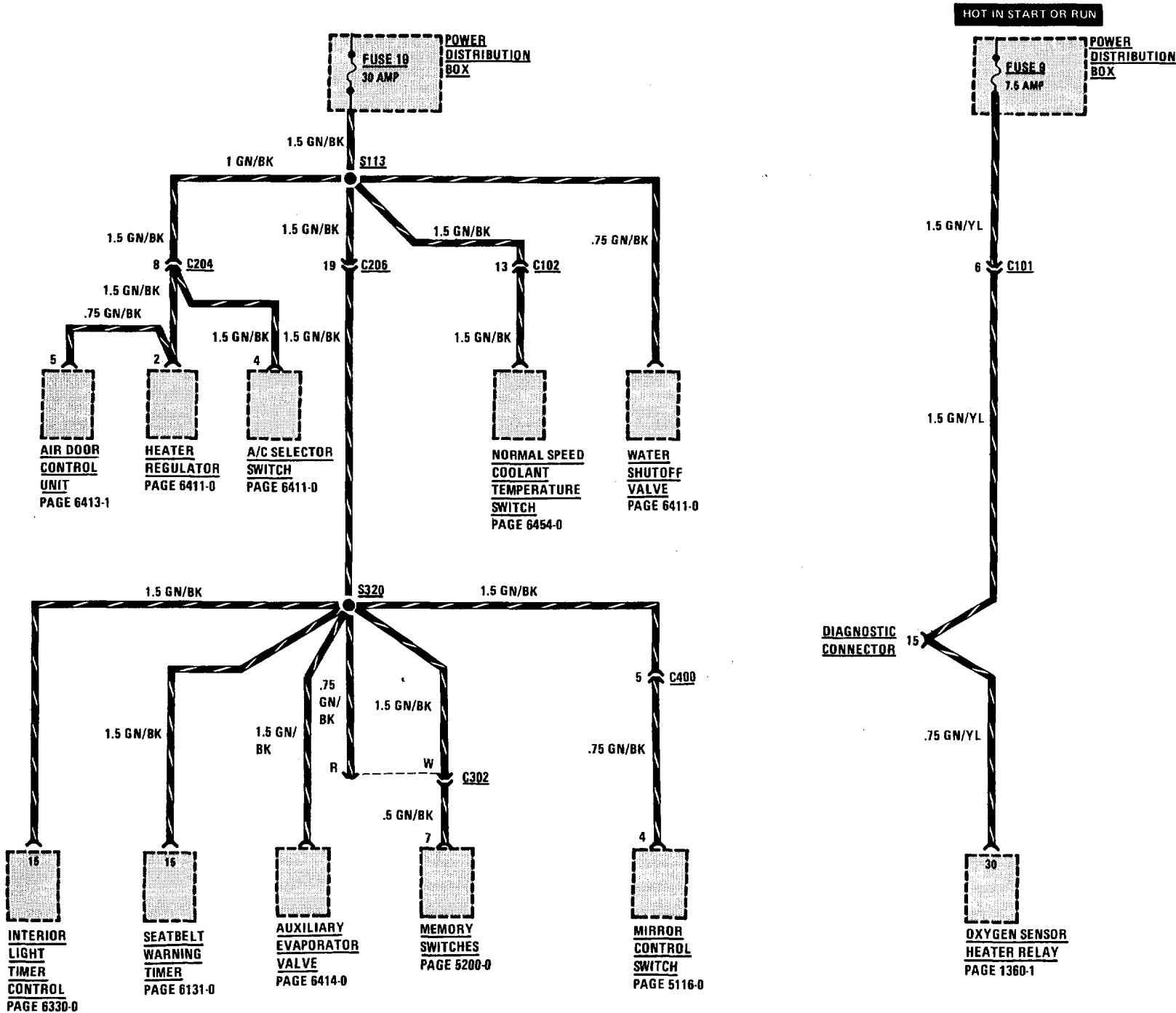

FUSE DETAILS: FUSES 6 AND 20

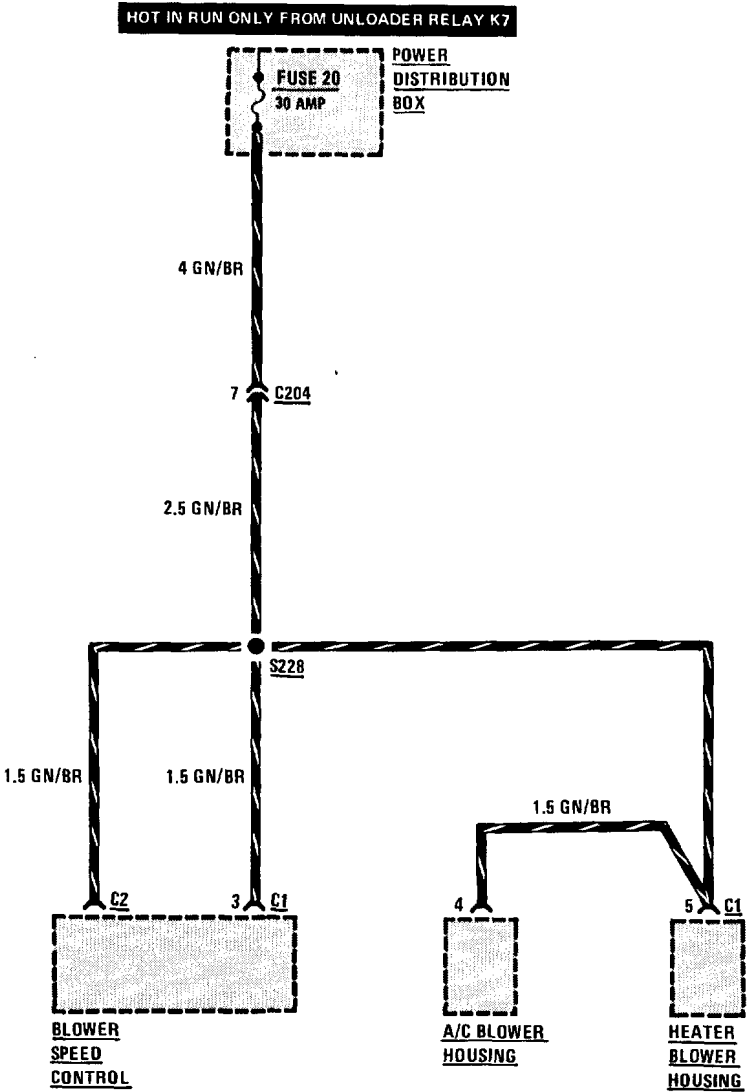
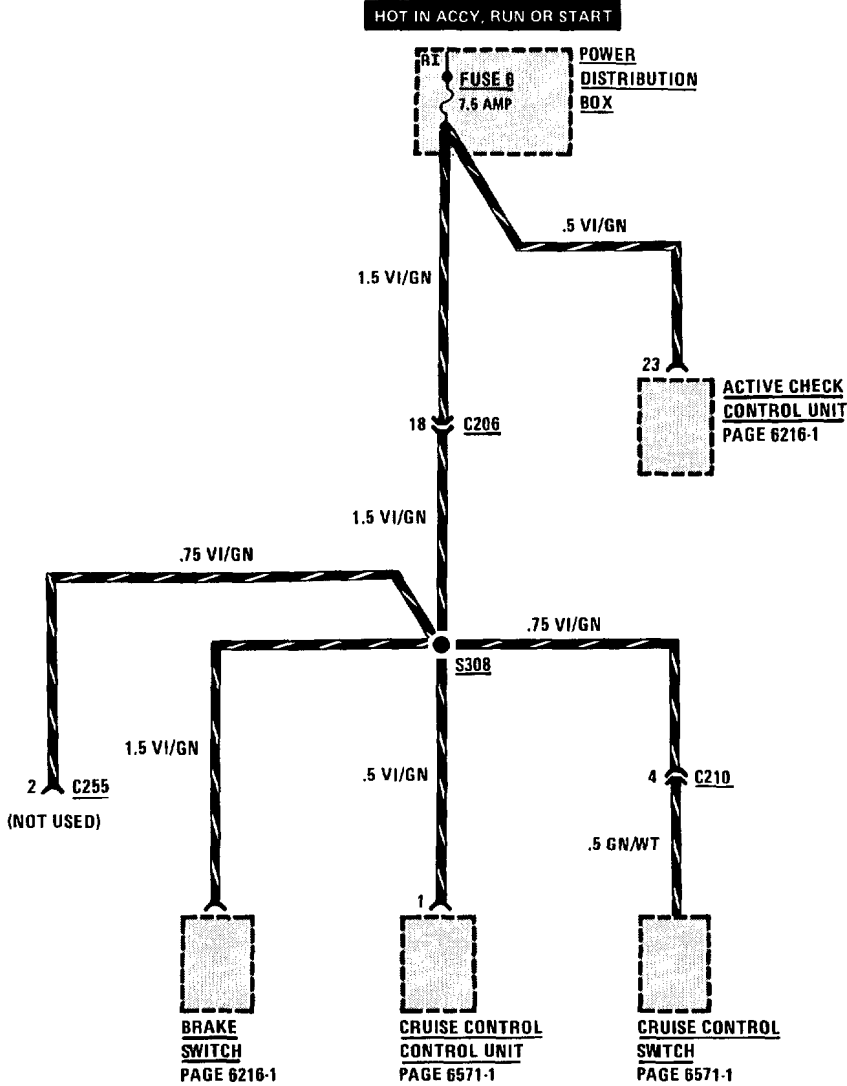

# 0670-10 POWER DISTRIBUTION

## FUSE DETAILS: FUSE 21

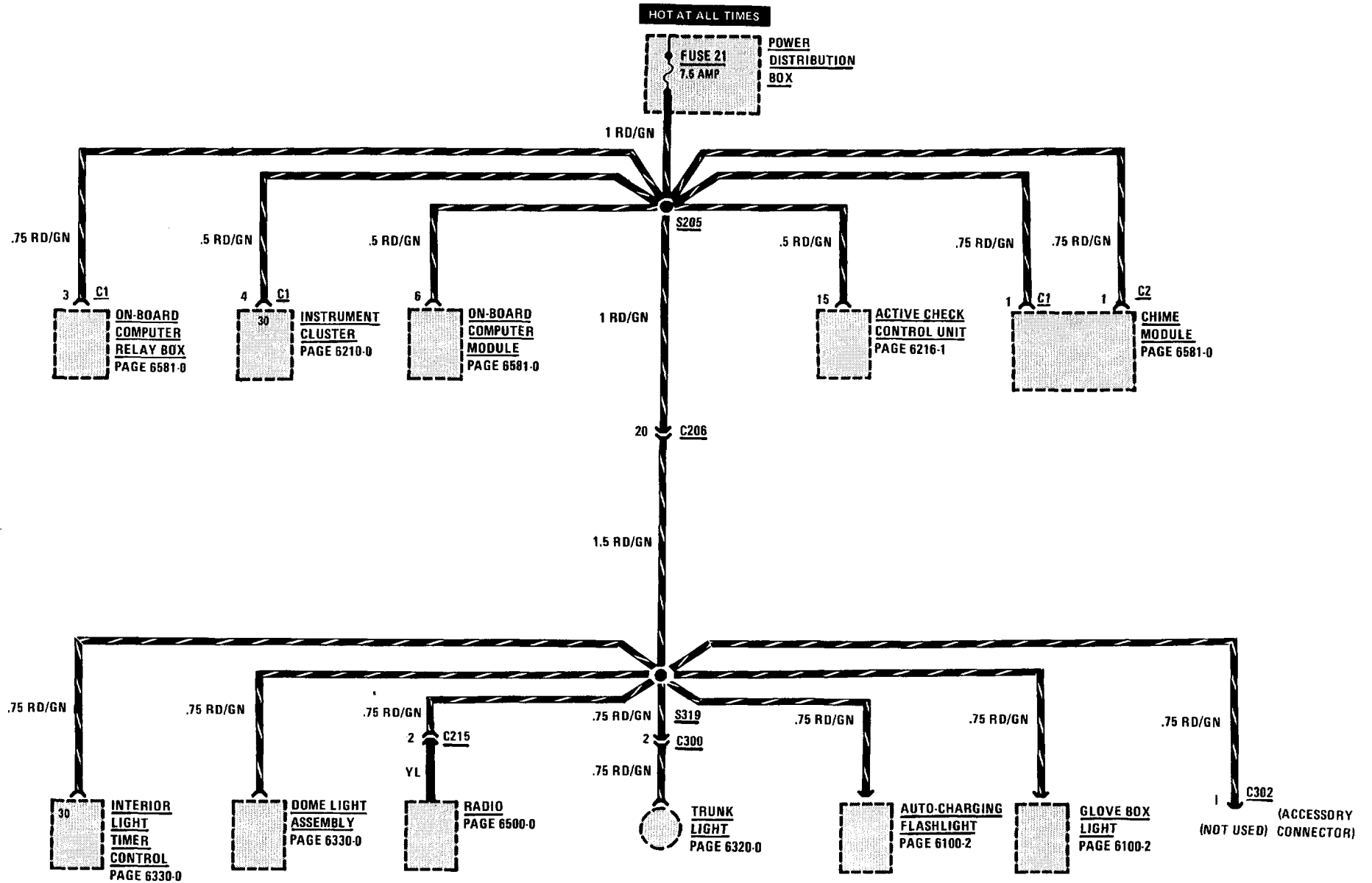

**GROUND DISTRIBUTION (G103 AND G104)**

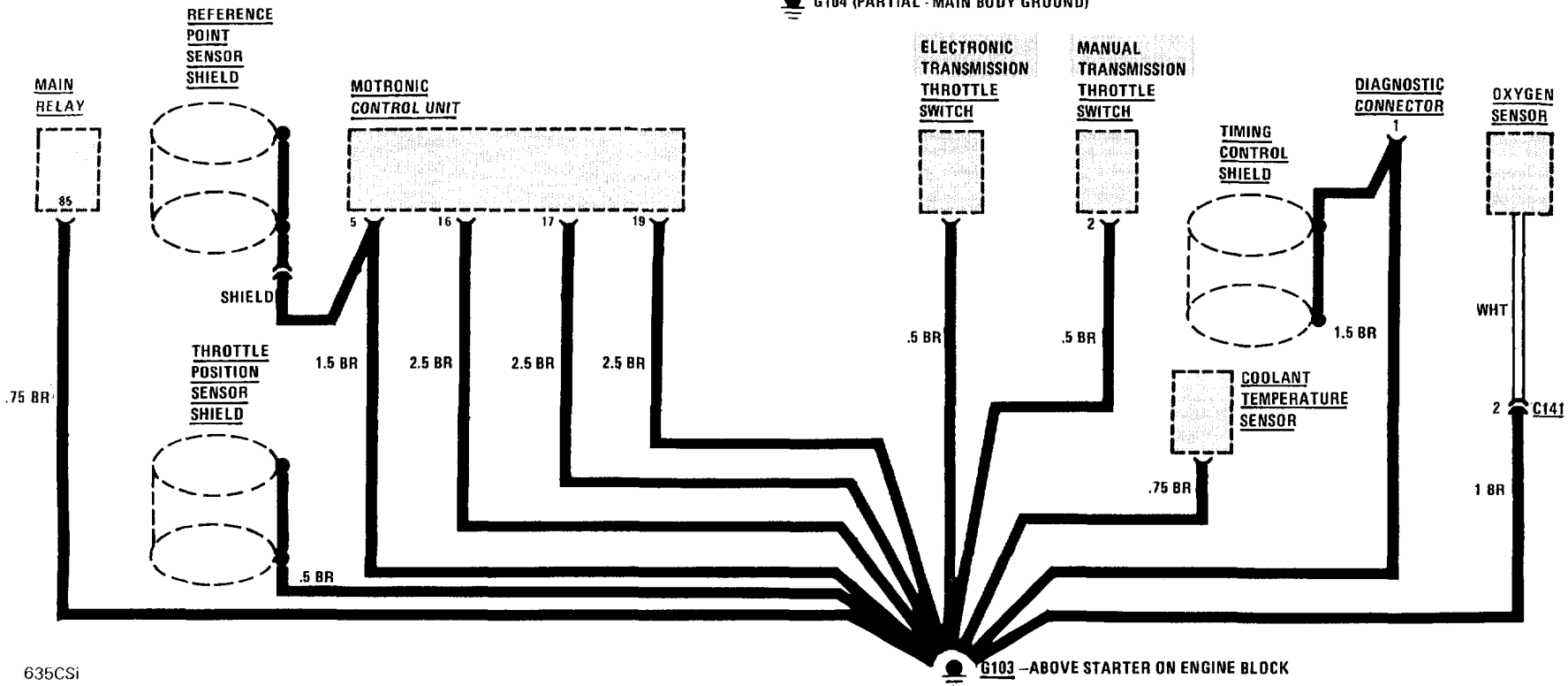
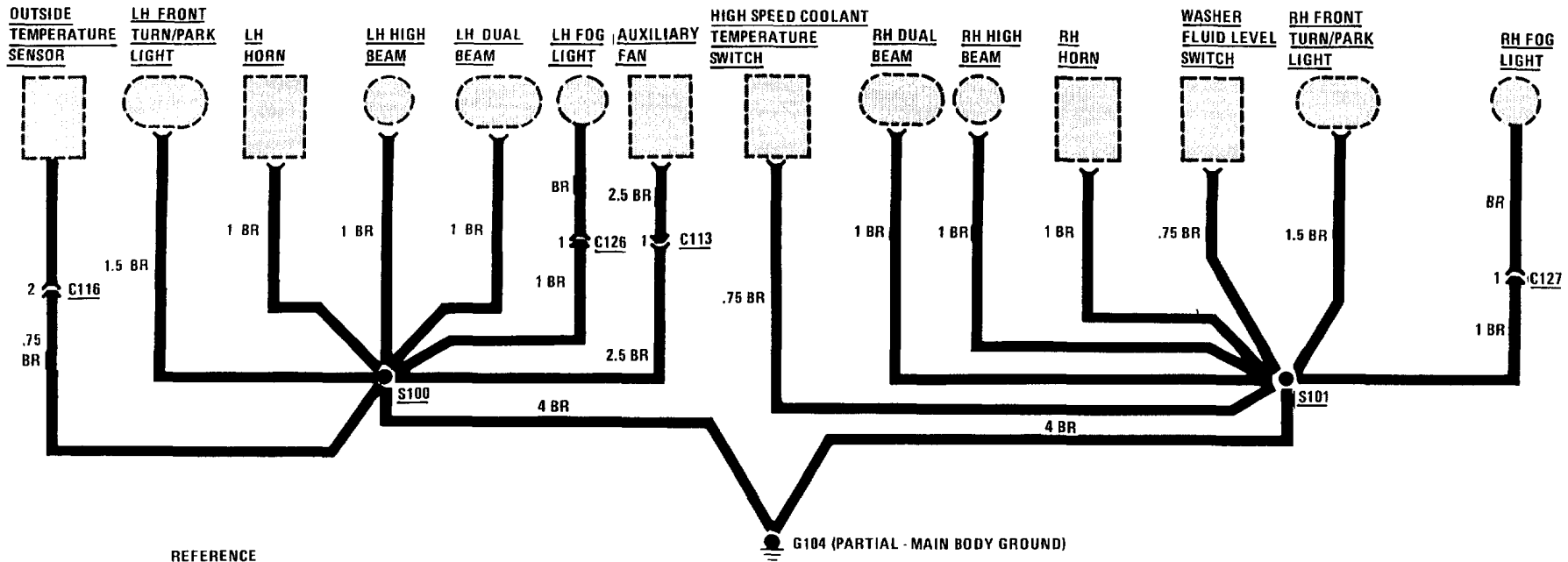

# 0670-12 POWER DISTRIBUTION

## GROUND DISTRIBUTION (G200 AND G201)

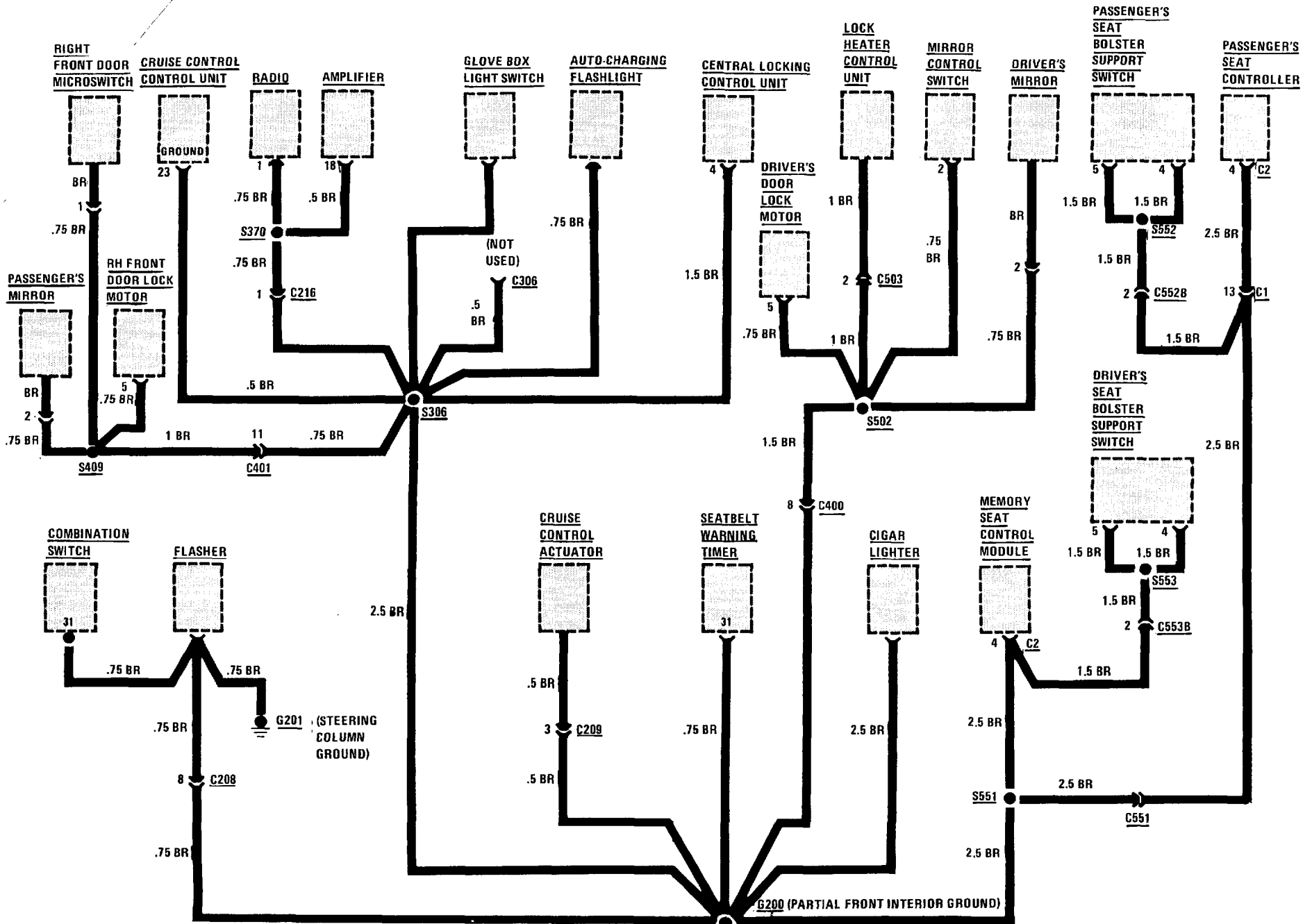

GROUND DISTRIBUTION (G200 AND G104)

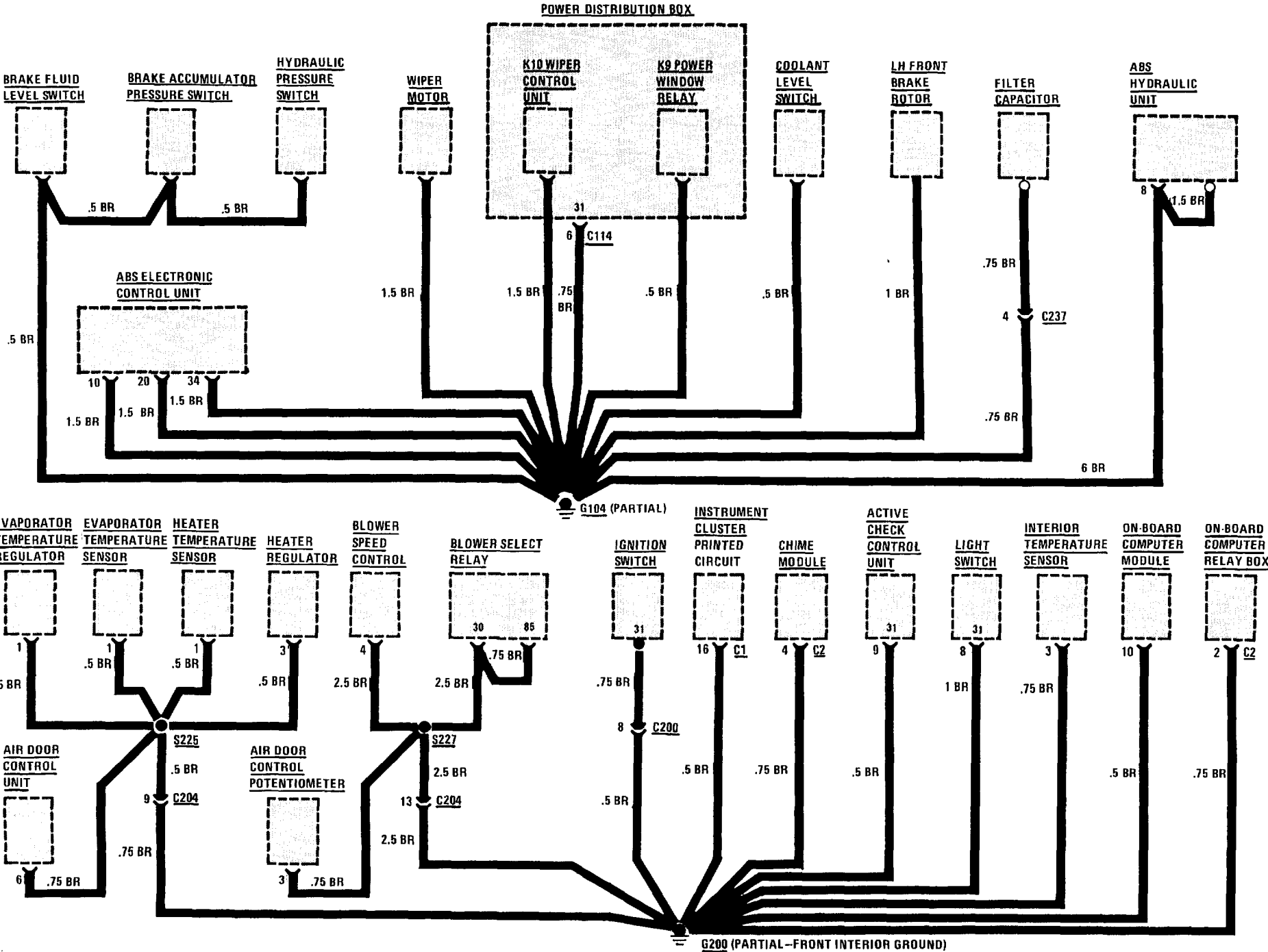



**GROUND DISTRIBUTION (G302)**

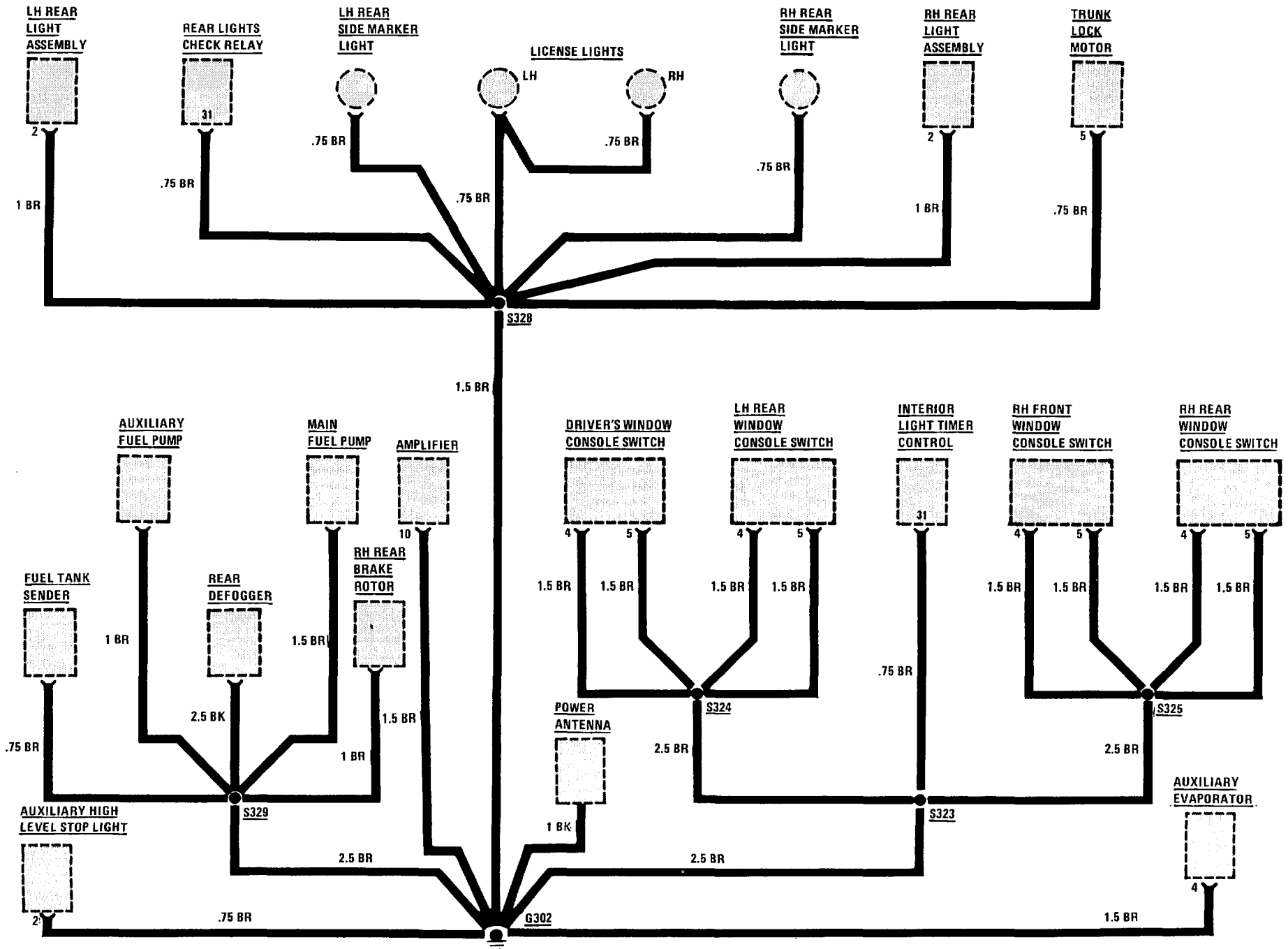

GROUND DISTRIBUTION (G101 AND G104)

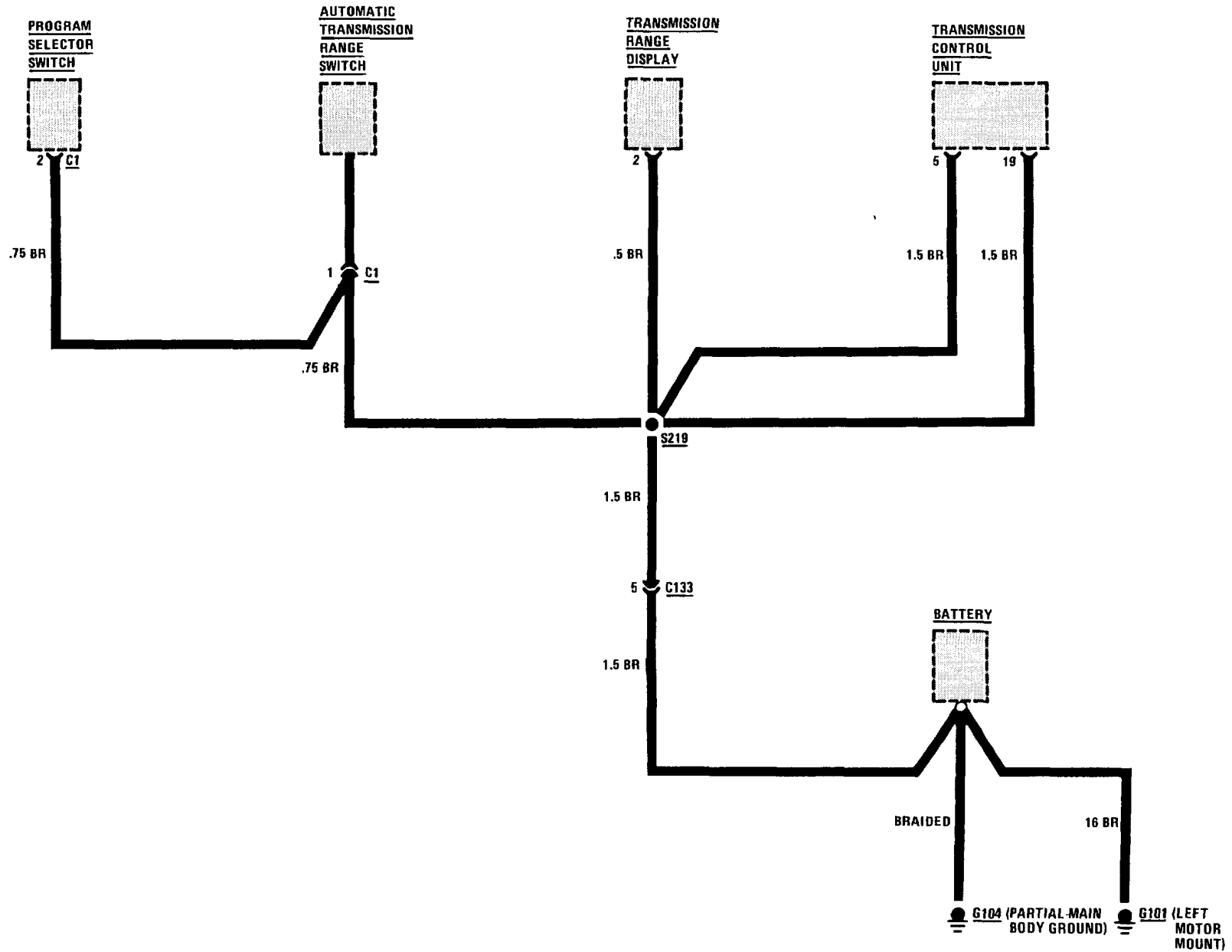

# 1230-0 CHARGING SYSTEM

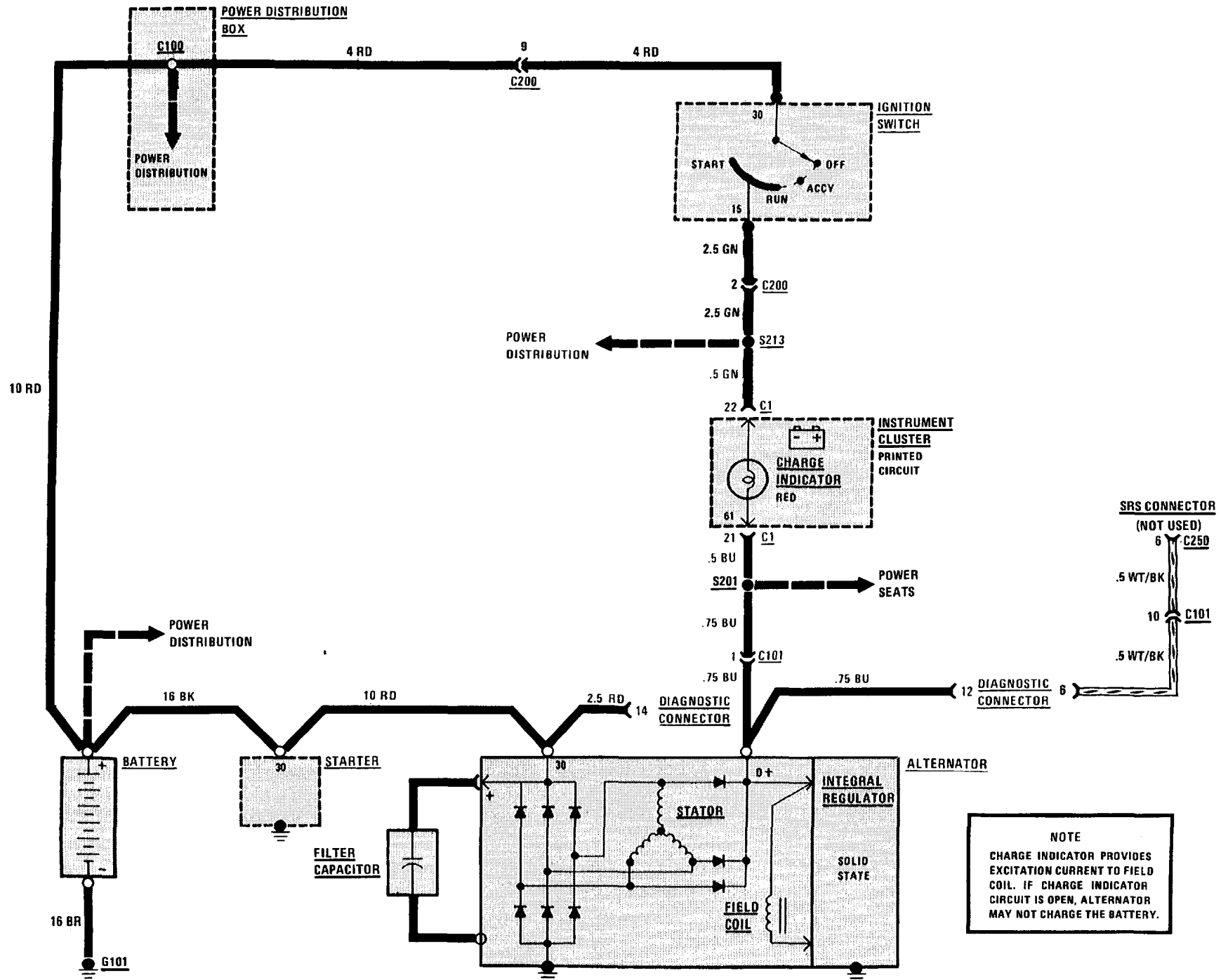

**NOTE**  
 CHARGE INDICATOR PROVIDES EXCITATION CURRENT TO FIELD COIL. IF CHARGE INDICATOR CIRCUIT IS OPEN, ALTERNATOR MAY NOT CHARGE THE BATTERY.

ELECTRONIC TRANSMISSION

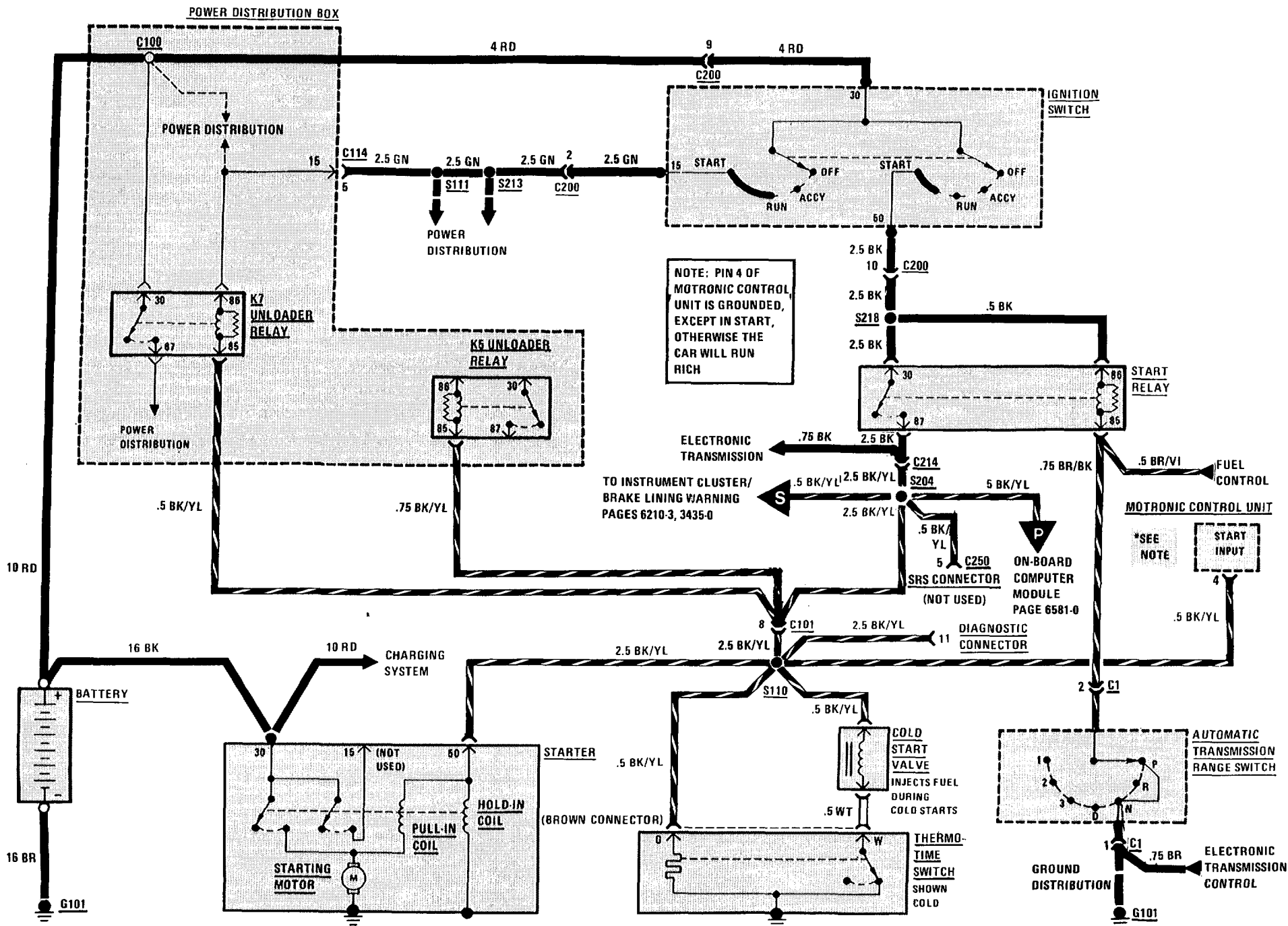

MANUAL TRANSMISSION

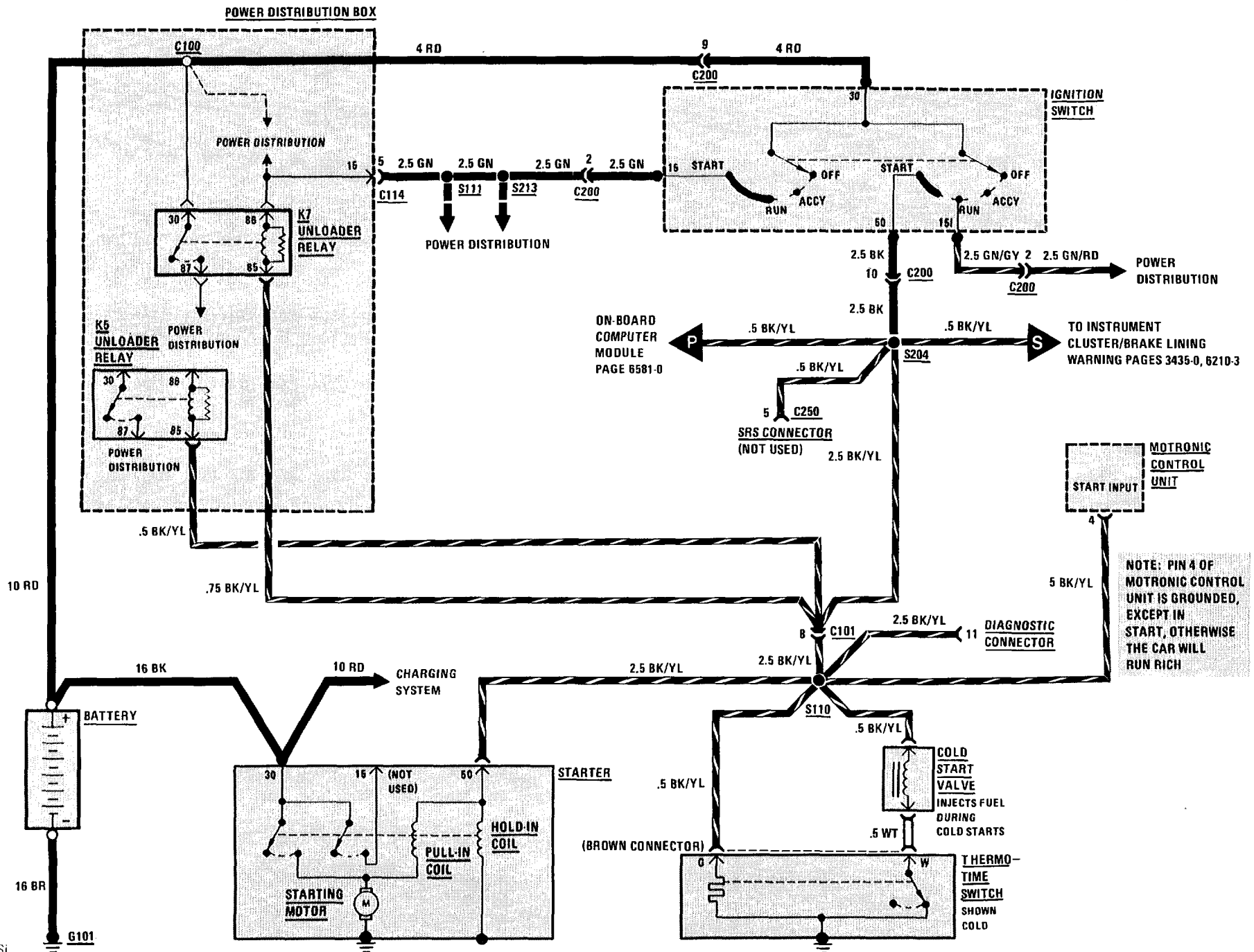

**MANUAL ONLY**

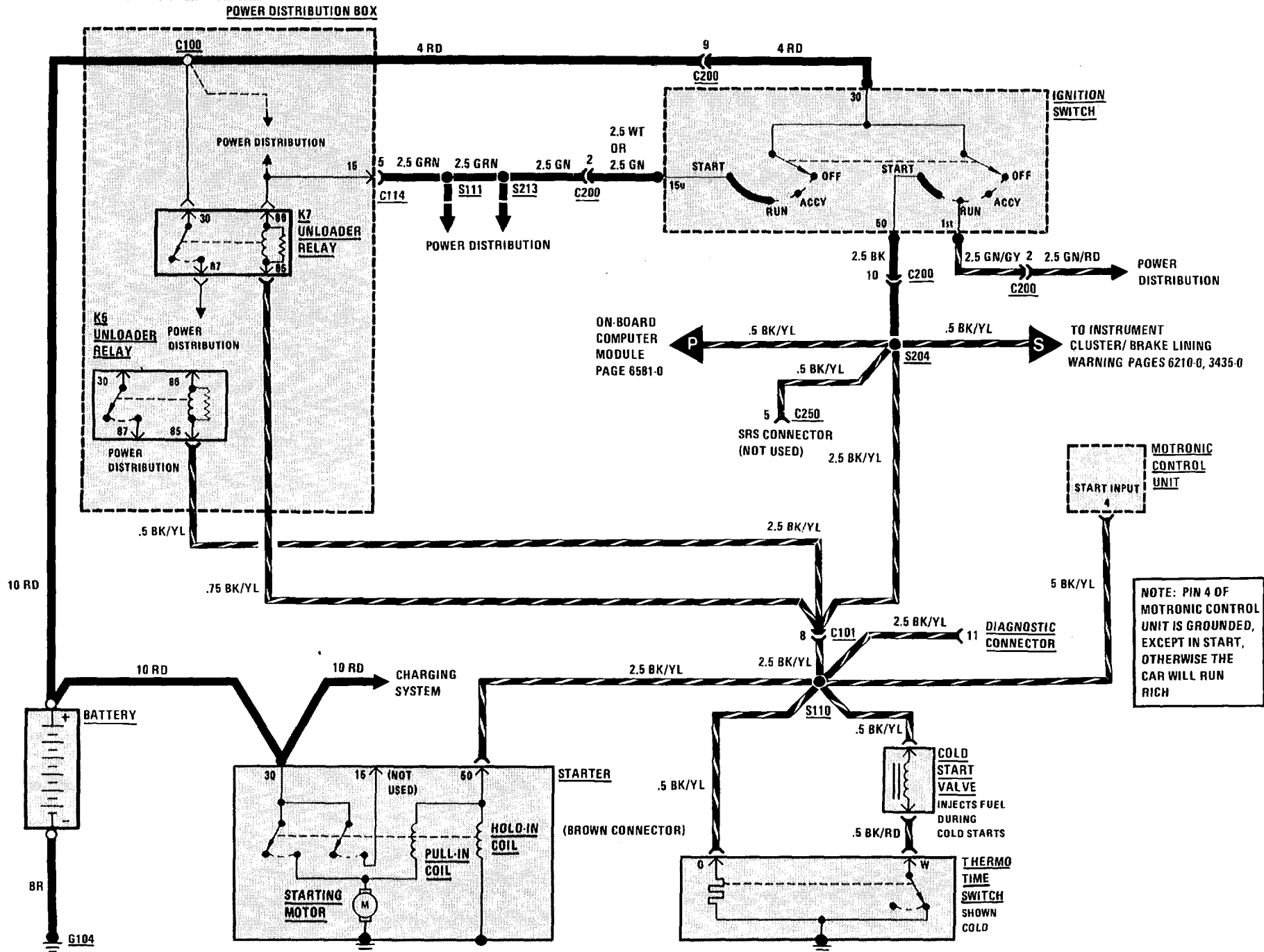

NOTE: PIN 4 OF MOTRONIC CONTROL UNIT IS GROUNDED, EXCEPT IN START, OTHERWISE THE CAR WILL RUN RICH

# 1250-0 ENGINE CONTROL BLOCK DIAGRAM

## ELECTRONIC TRANSMISSION

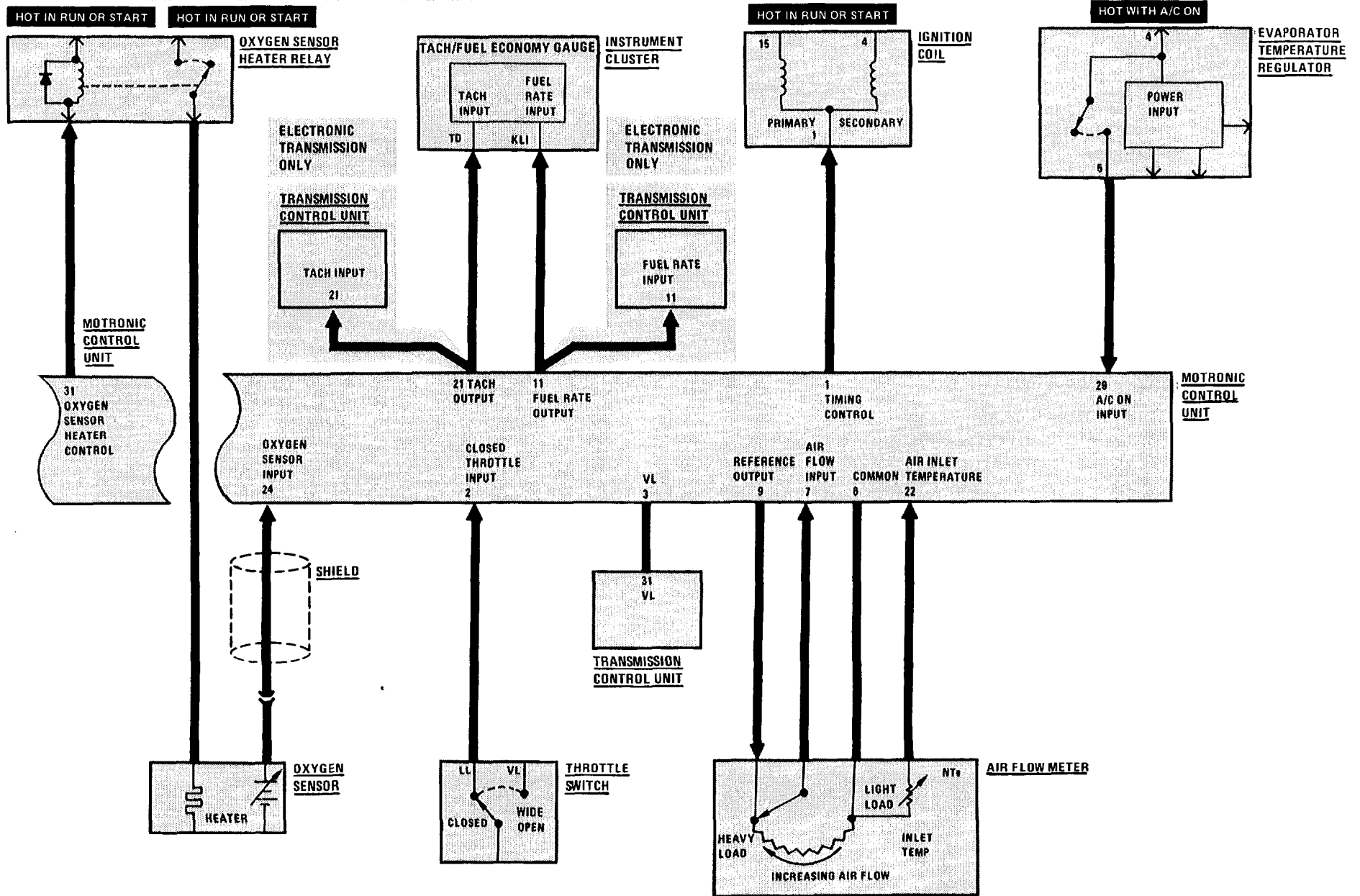

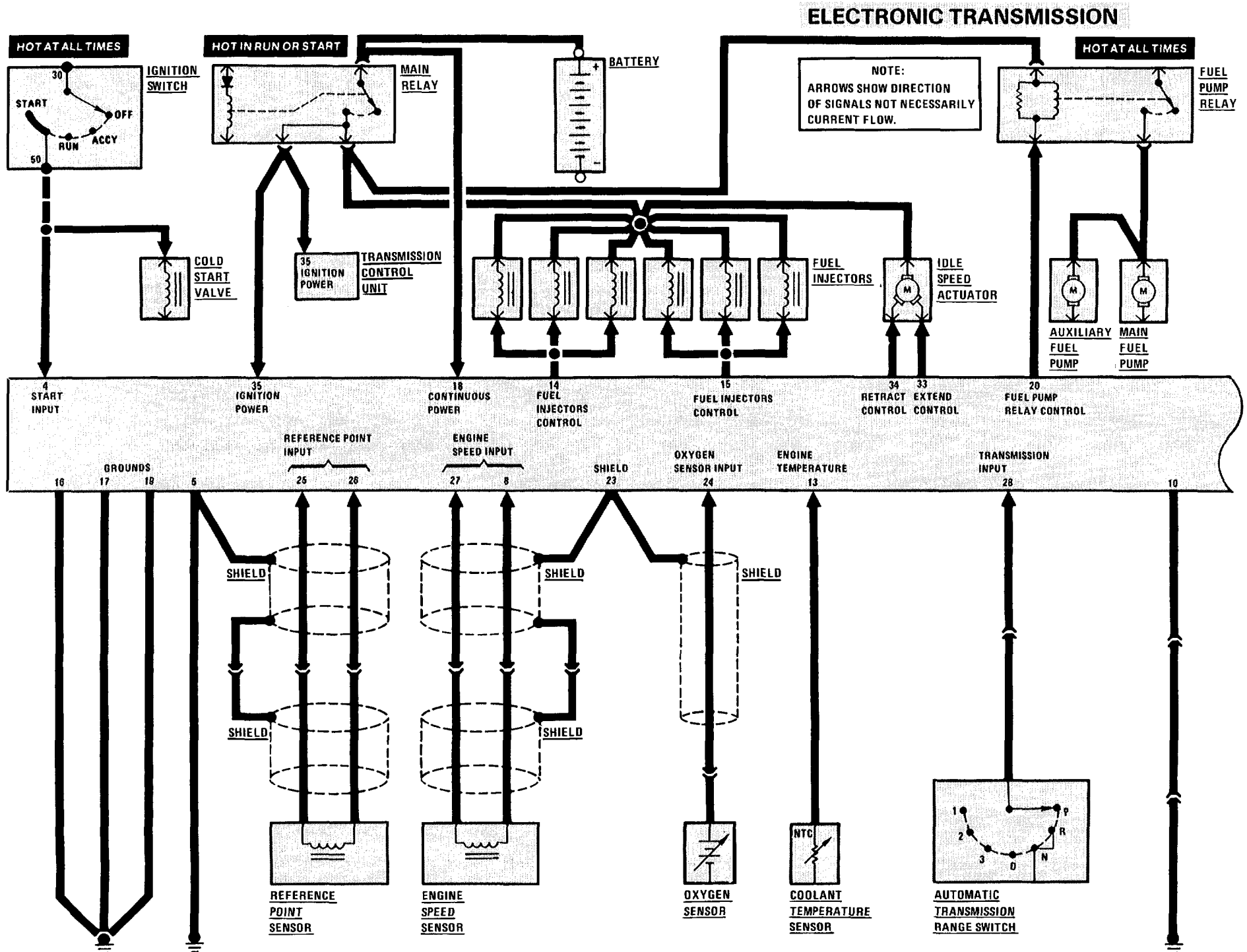



# 1250-2 ENGINE CONTROL BLOCK DIAGRAMS

## MANUAL TRANSMISSION

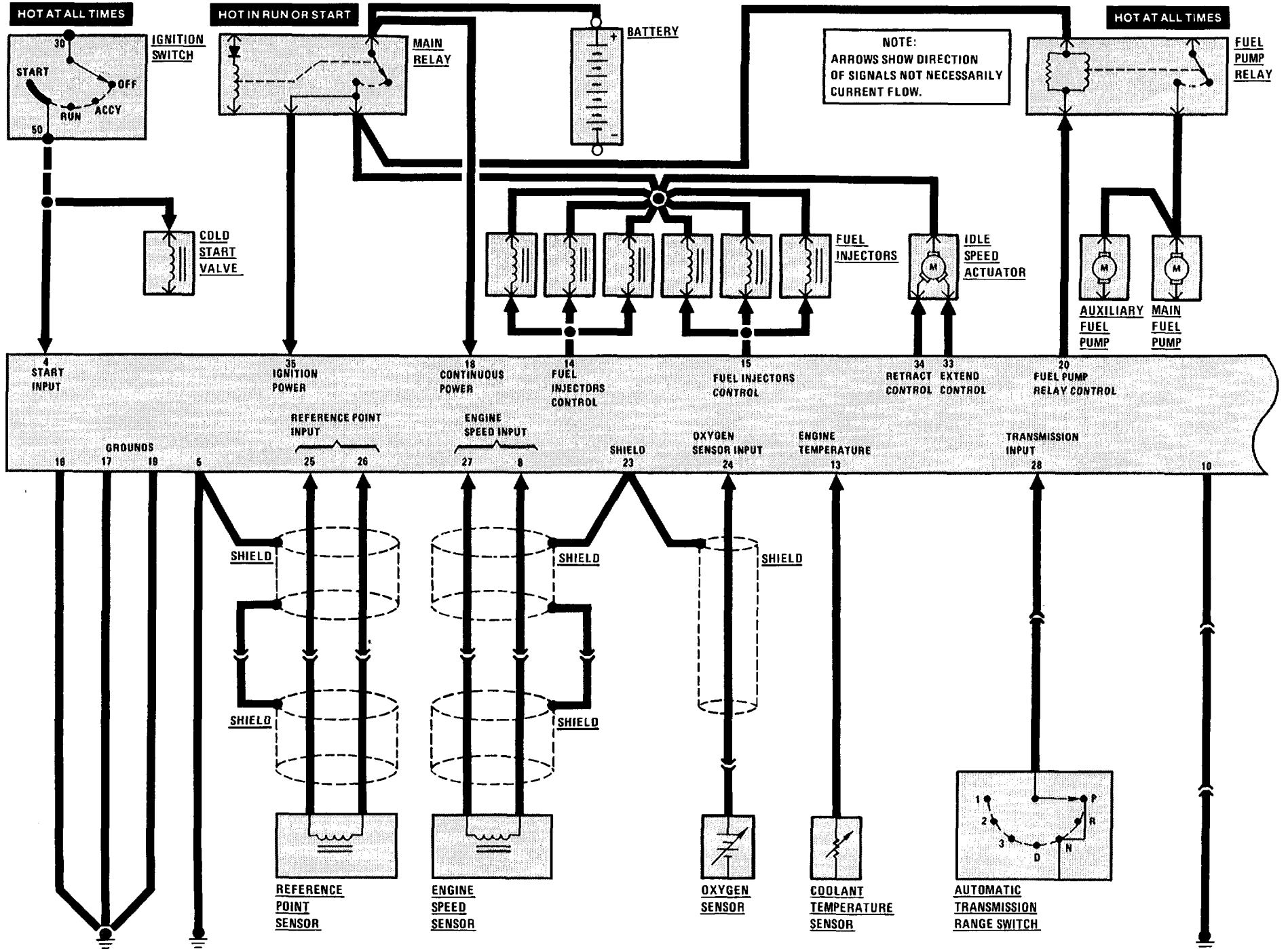

MANUAL TRANSMISSION

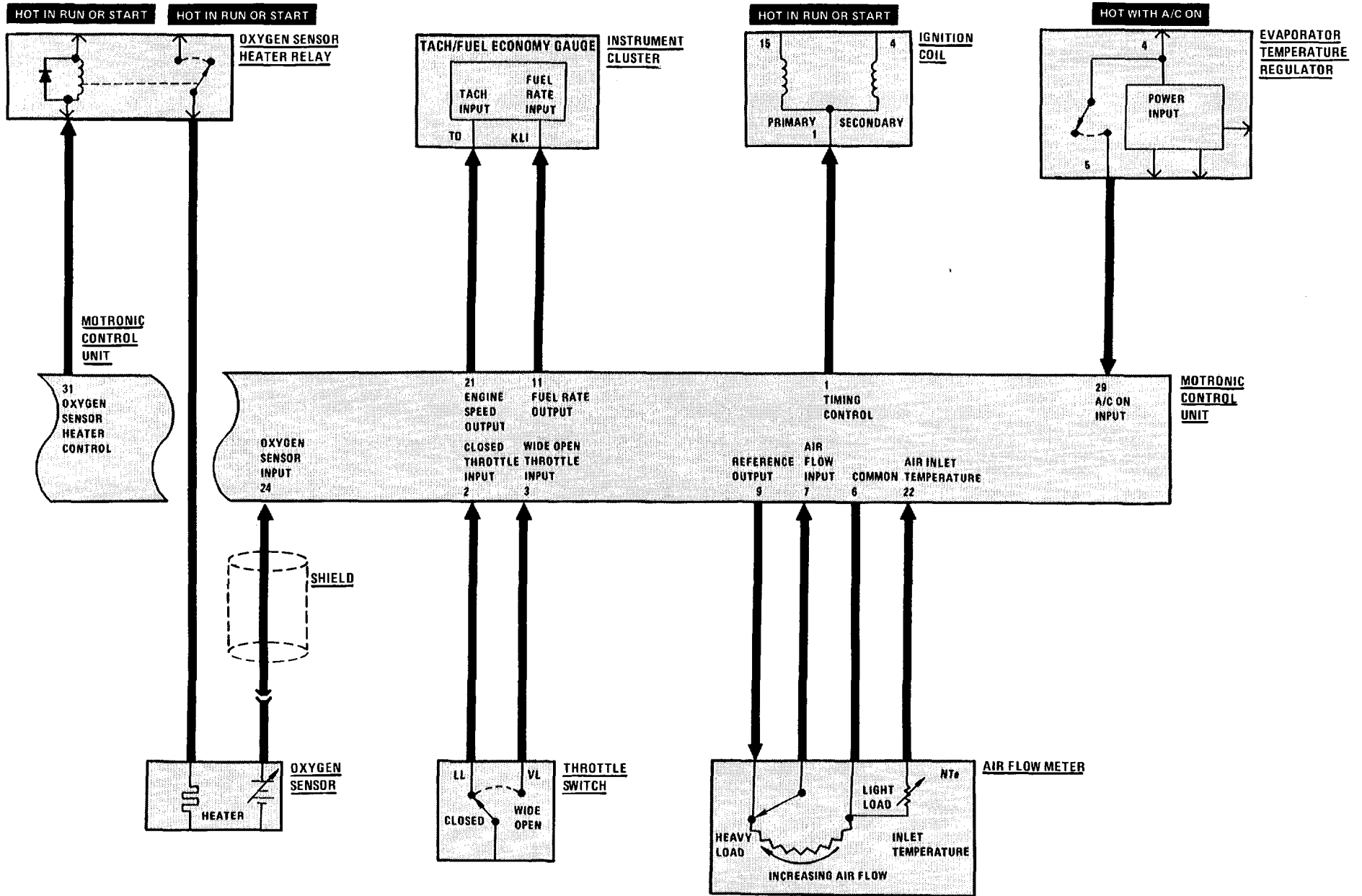

FUEL DELIVERY/FUEL CONTROL (ELECTRONIC TRANSMISSION)

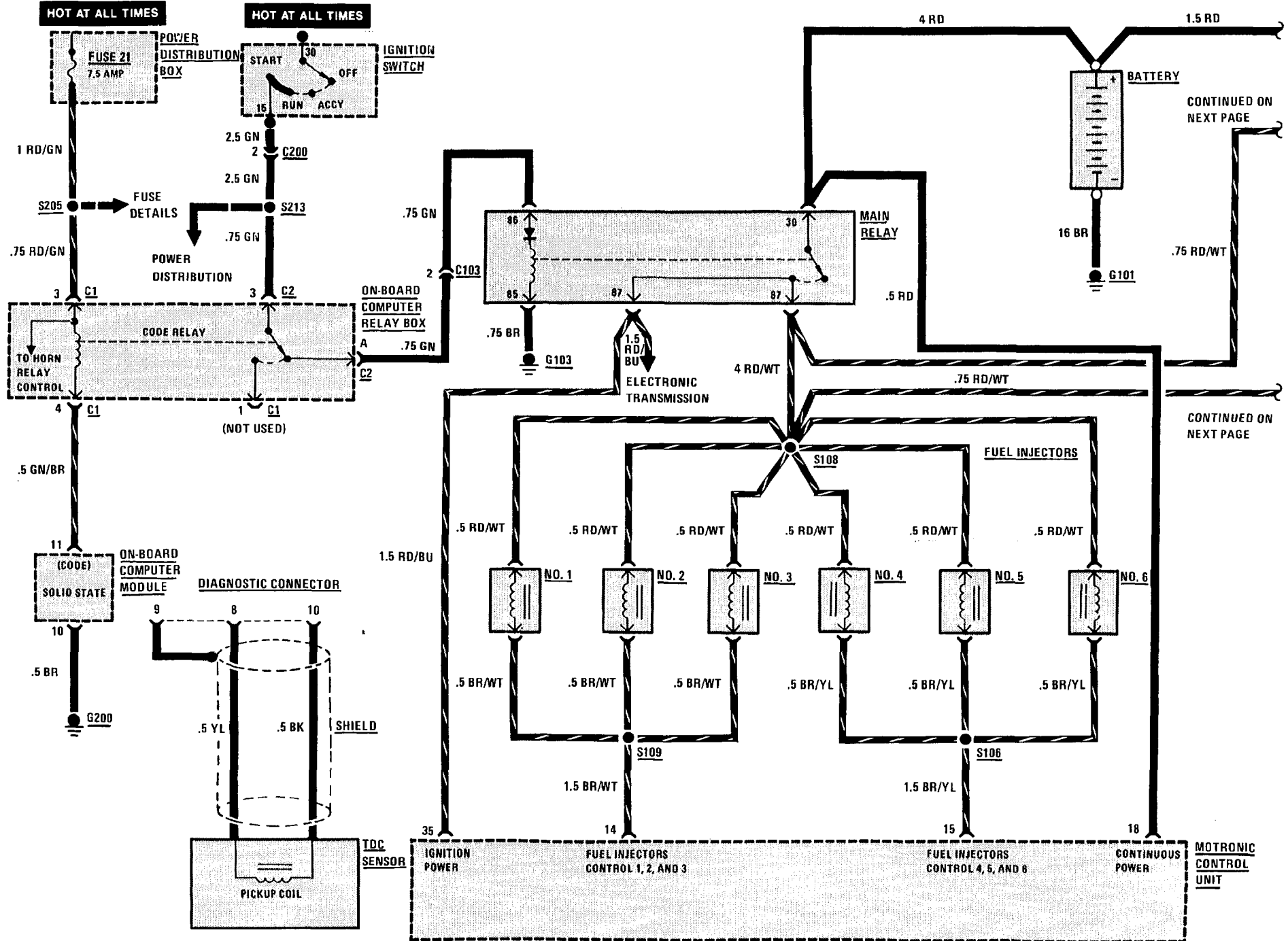

FUEL DELIVERY/FUEL CONTROL/IDLE SPEED CONTROL (ELECTRONIC TRANSMISSION)

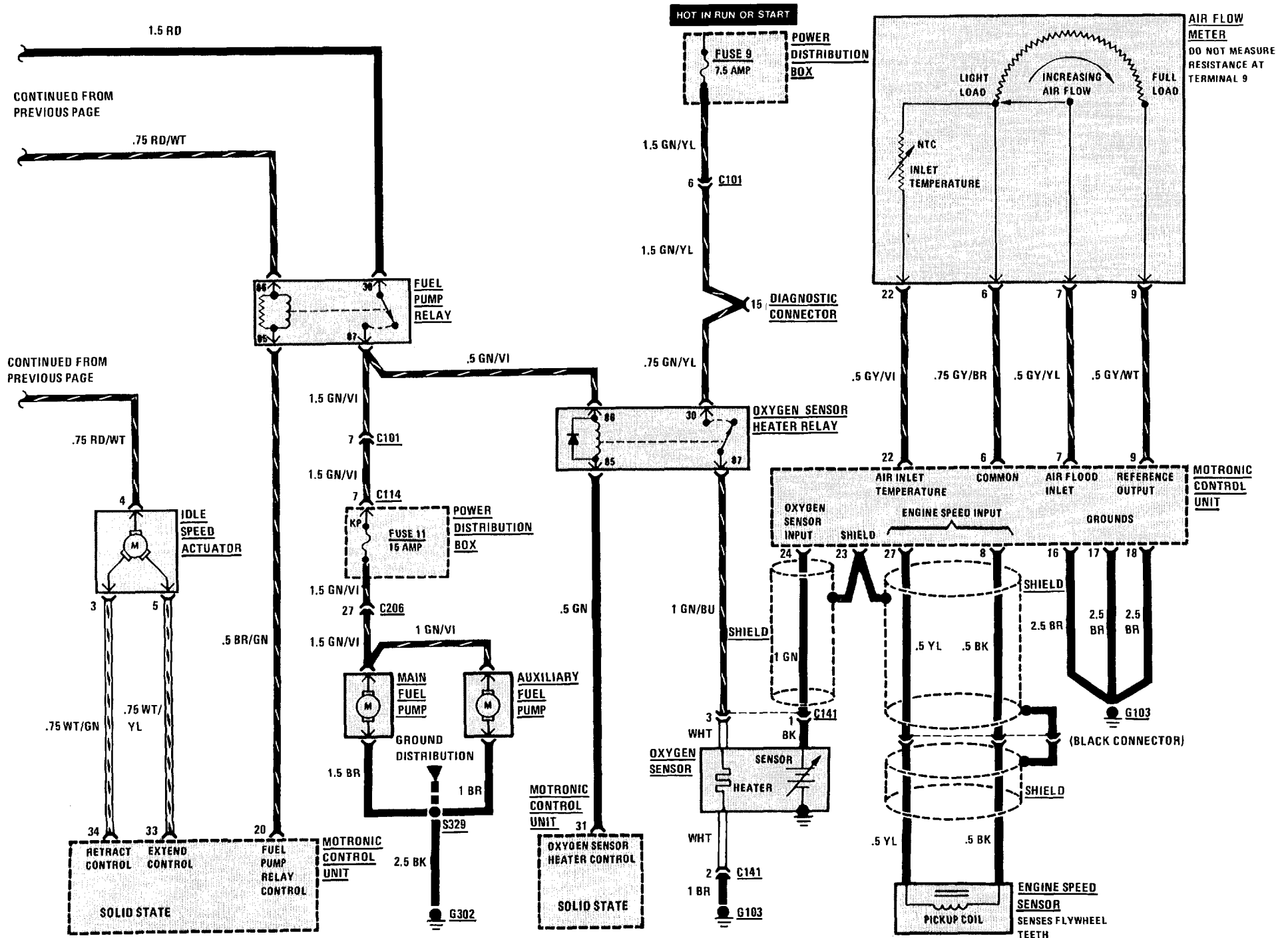

# 1360-2 INJECTION ELECTRONICS

## IGNITION/FUEL CONTROL (ELECTRONIC TRANSMISSION)

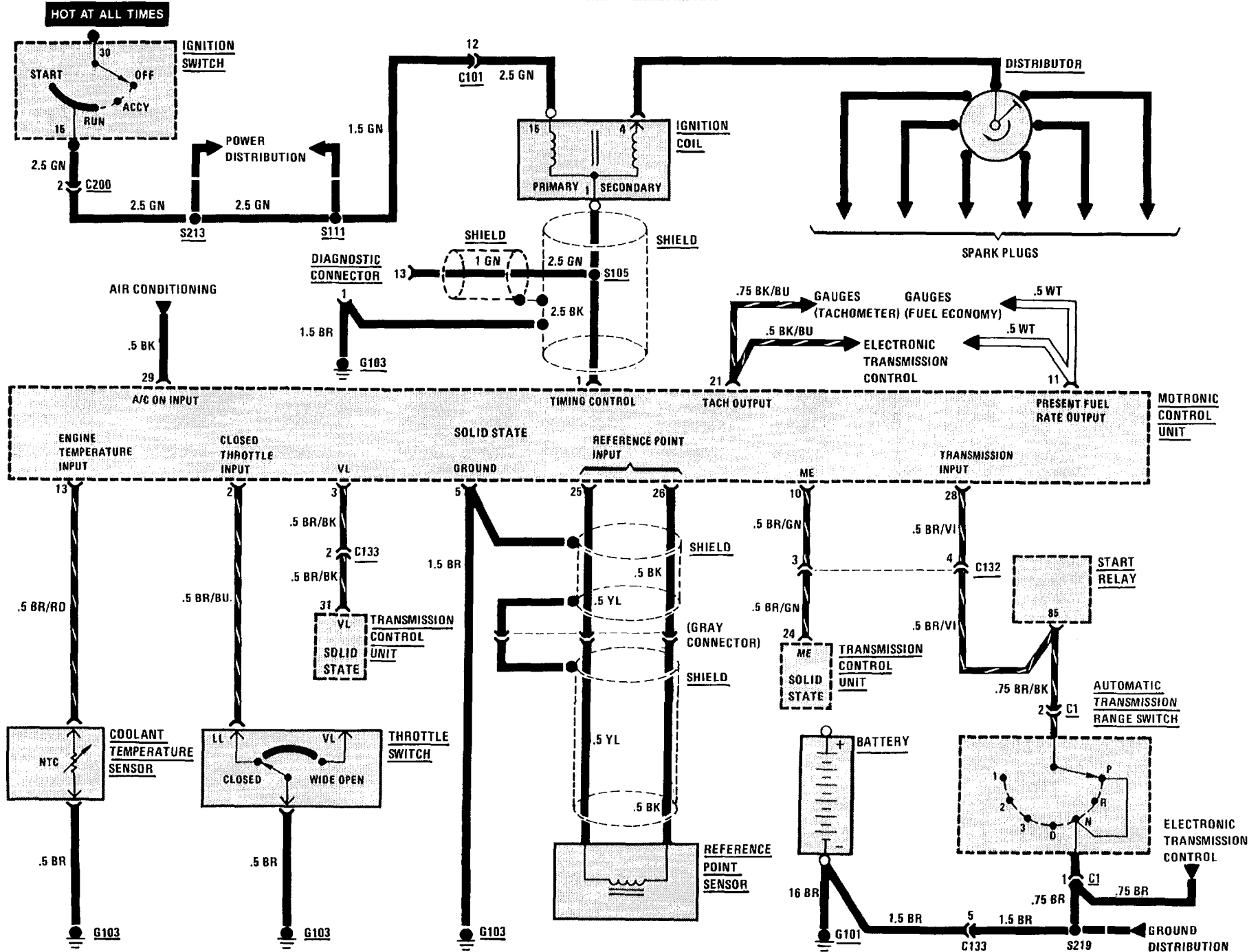

FUEL CONTROL/IGNITION (MANUAL TRANSMISSION)

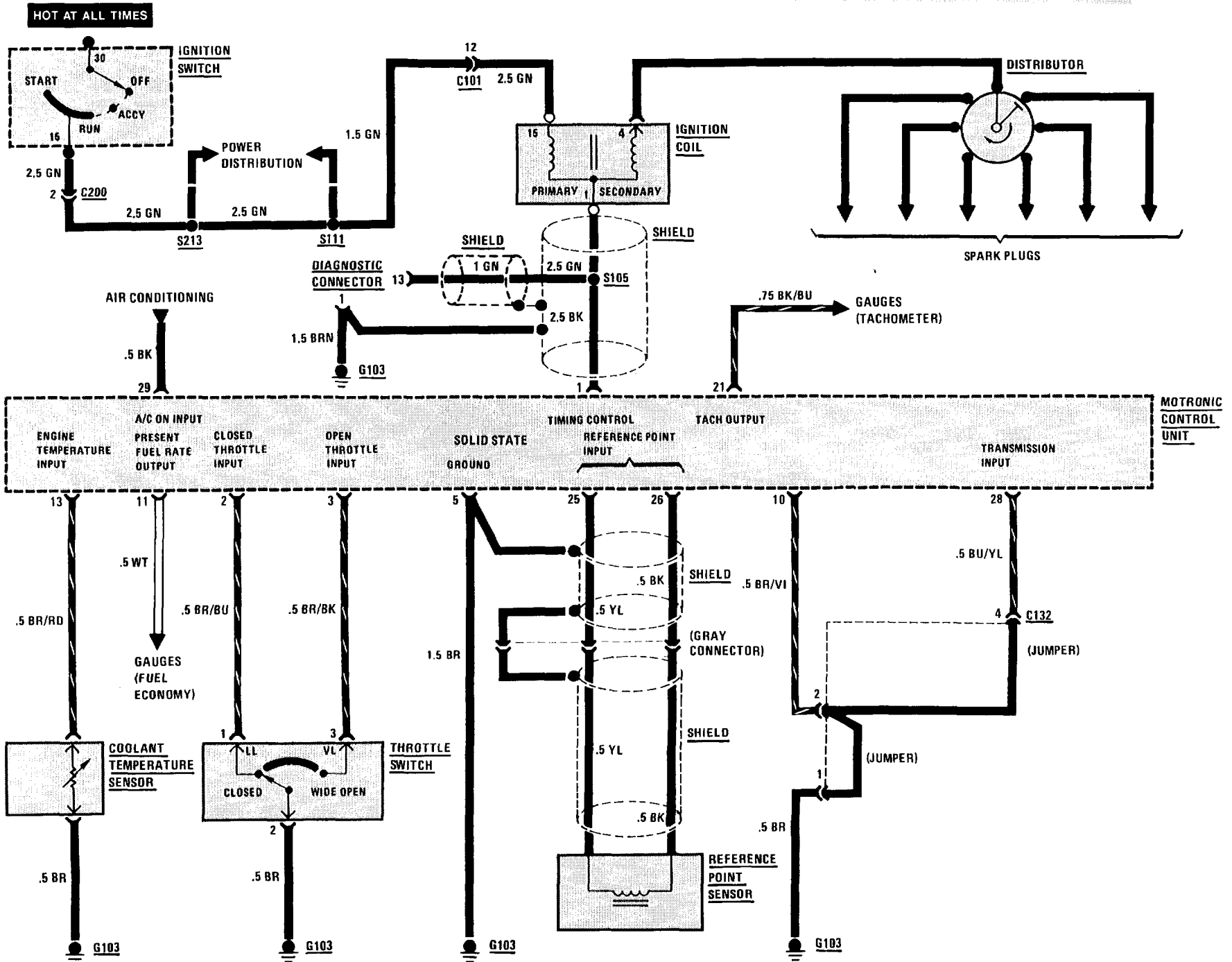

# 1360-4 INJECTION ELECTRONICS

## FUEL DELIVERY/FUEL CONTROL (MANUAL TRANSMISSION)

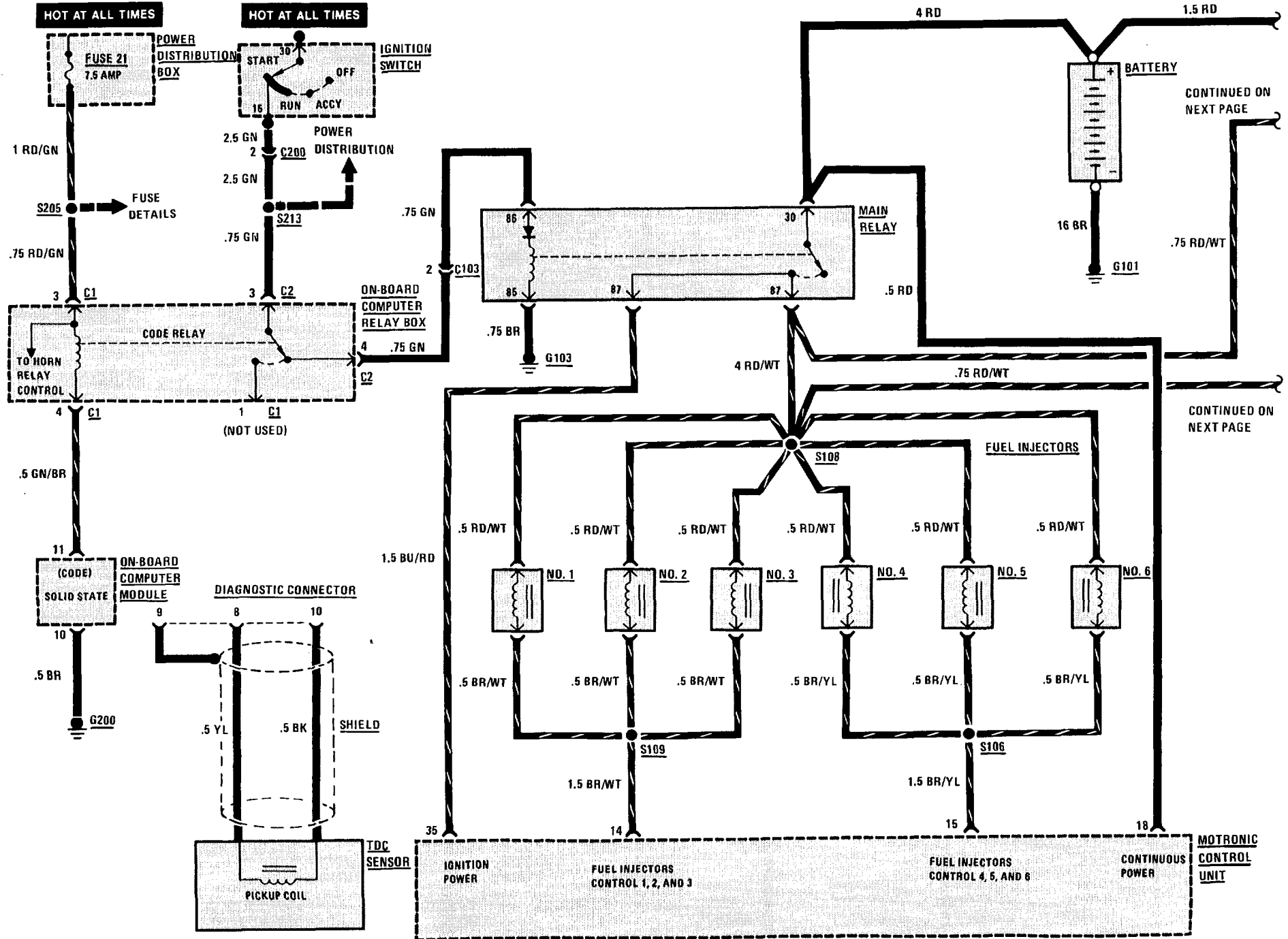

FUEL DELIVERY/FUEL CONTROL/IDLE SPEED CONTROL (MANUAL TRANSMISSION)

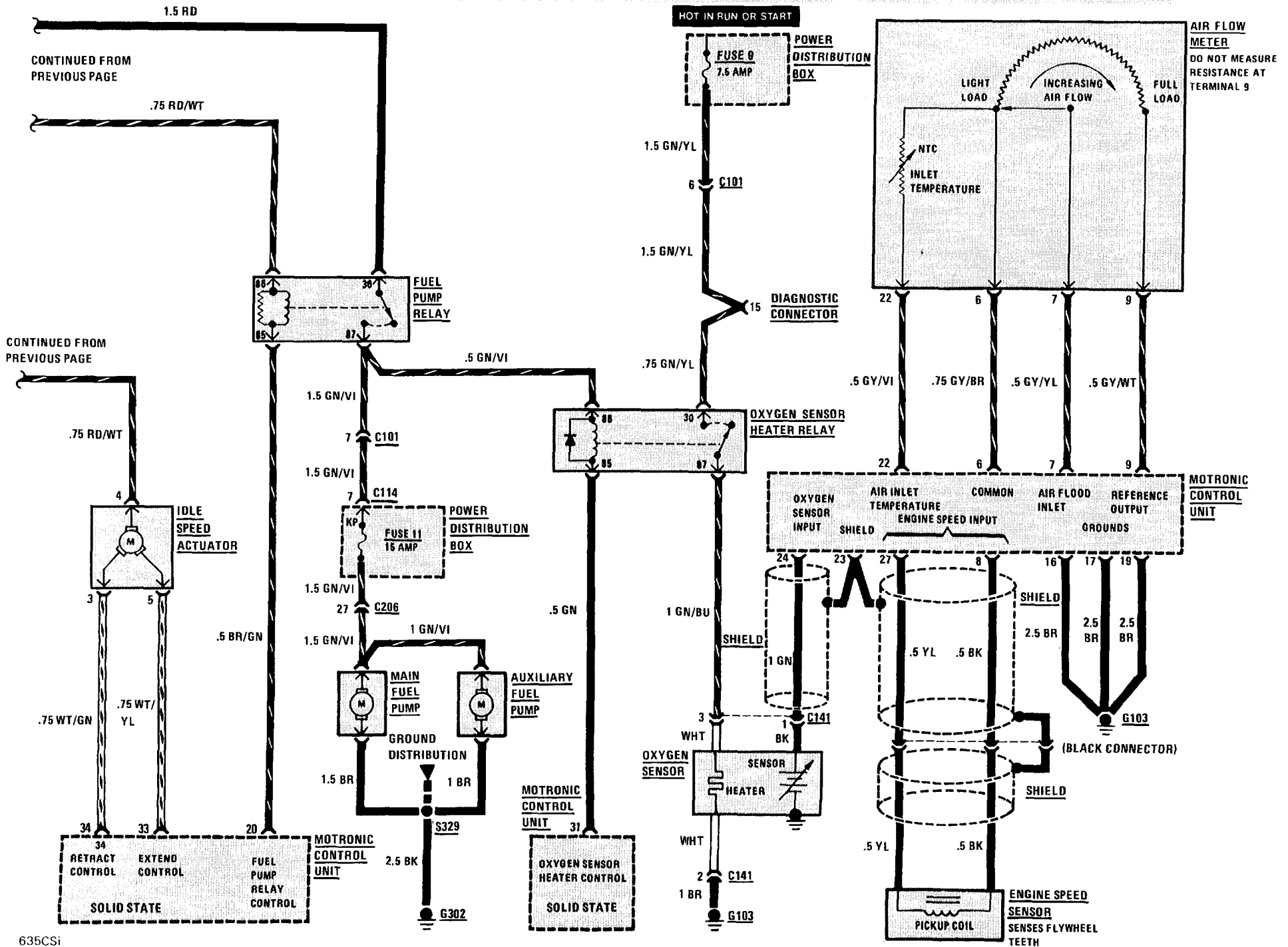



# 2460-0 ELECTRONIC TRANSMISSION CONTROL

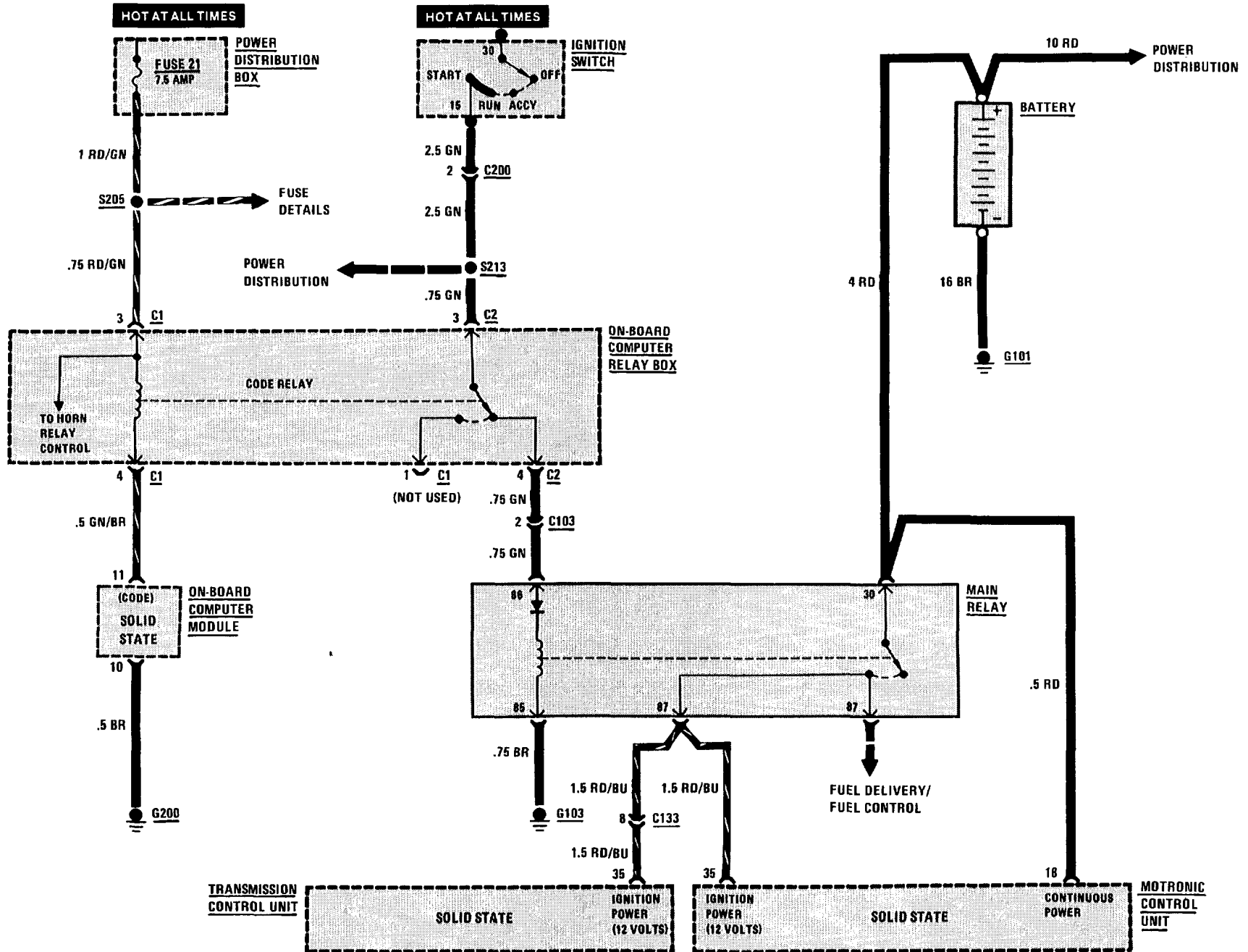

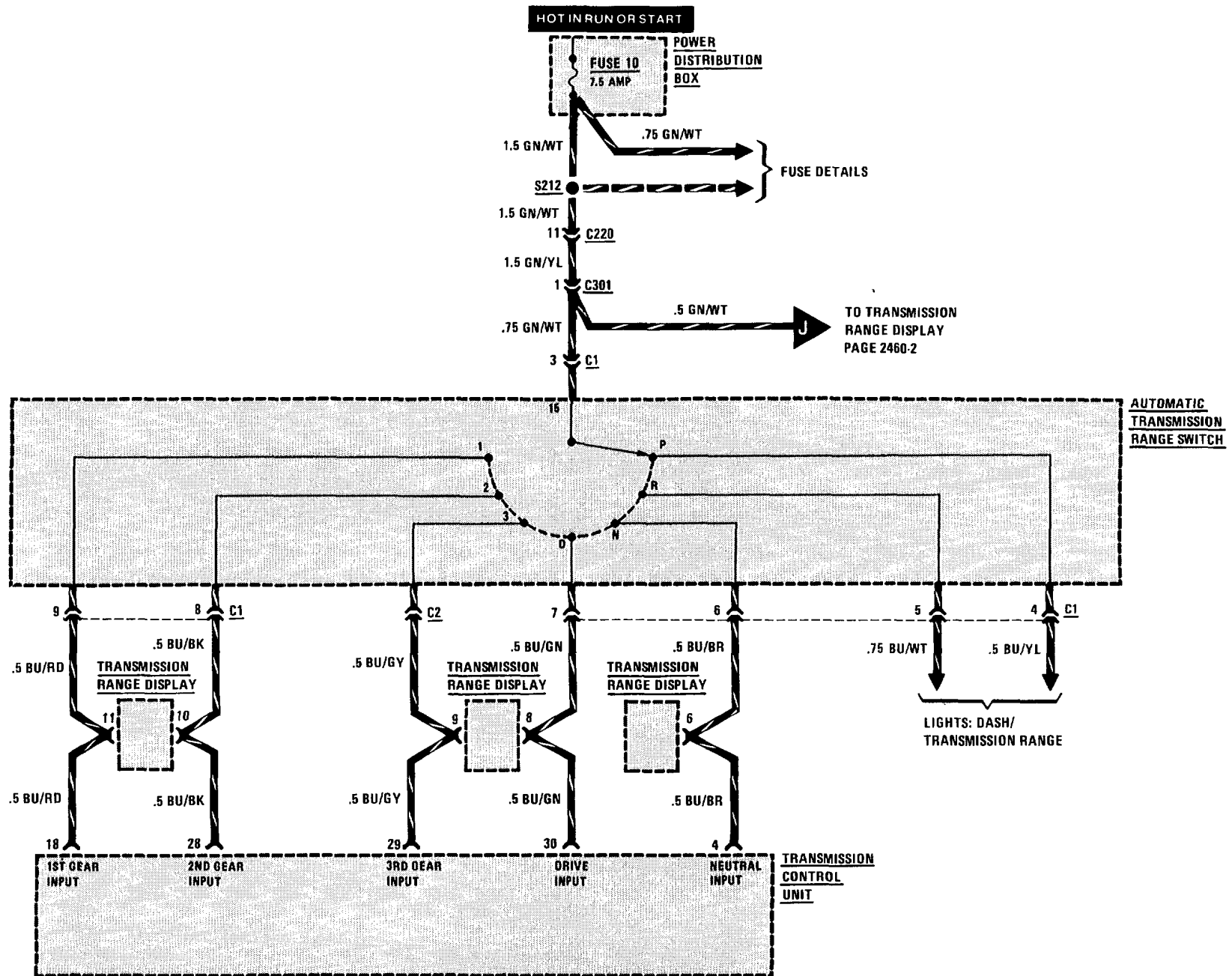

# 2460-2 ELECTRONIC TRANSMISSION CONTROL

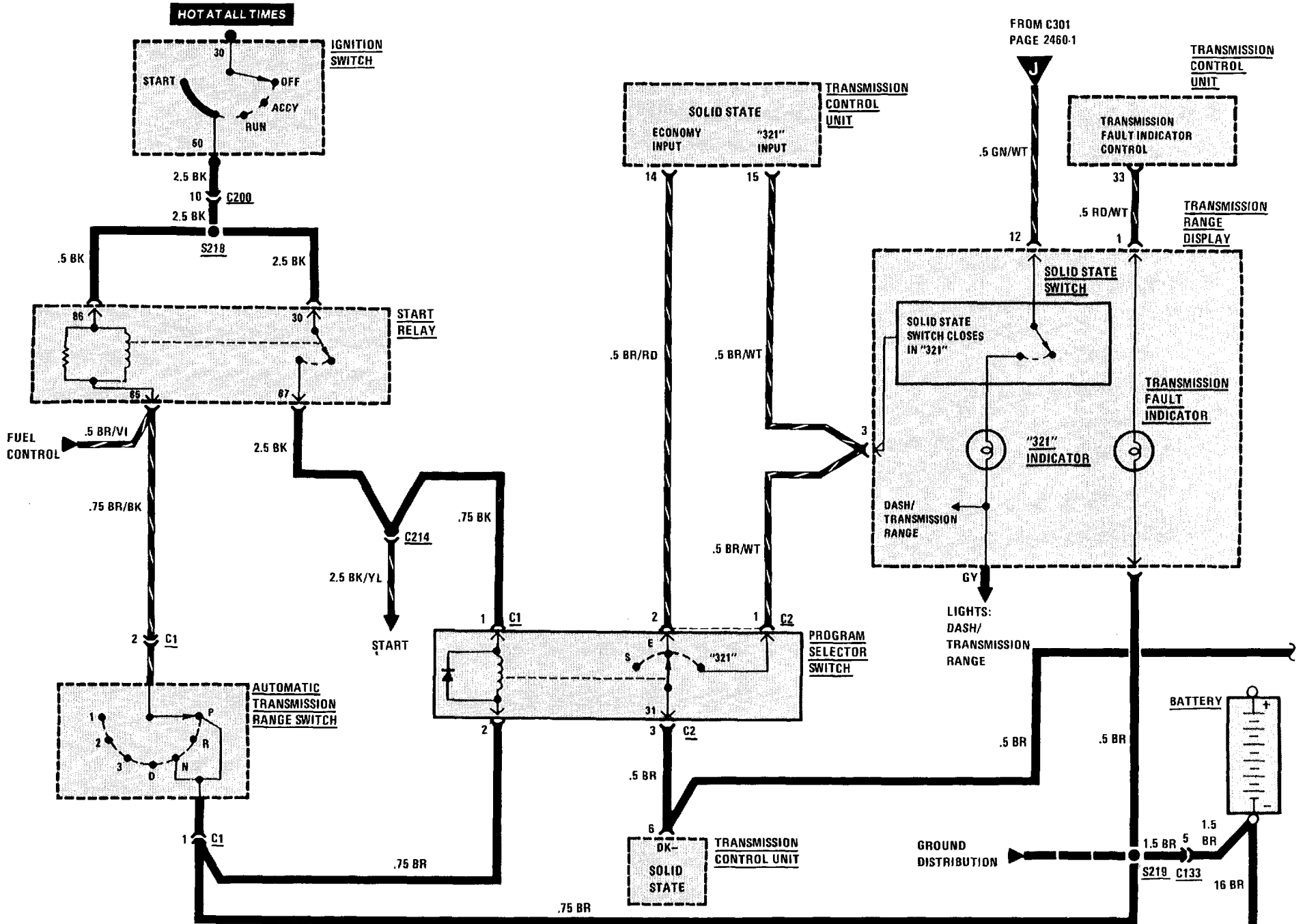



# 2460-4 ELECTRONIC TRANSMISSION CONTROL

## TROUBLESHOOTING HINTS

- Try the following check before doing the System Check.  
Check Fuse 6 if all the Transmission Range Display bulbs do not operate.

- Go to System Check for a guide to Normal Operation.

- Go to System Diagnosis for diagnostic tests.

## SYSTEM CHECK

- Use the System Check Table as a guide to normal operation.
- Refer to System Diagnosis for a list of symptoms and diagnostic steps.

**SYSTEM CHECK TABLE**

ACTION	NORMAL OPERATION
Turn the Ignition Switch to RUN	The Transmission Fault Indicator flashes twice, then stays on
Set the Program Selector Switch to "321"	The "321" Indicator lights
Crank the engine	The Program Selector Switch returns to E
Start the engine	The Transmission Fault Indicator goes out with the engine running
Drive the car with the Program Selector Switch in "321"	The car operates in selected gear only (first, second, or third gear)

(Continued in next column)

## COMPONENT LOCATION

Page-Figure

Auto. Trans. Range Switch . . . . .	On left side of shift lever	
Ignition Switch . . . . .	In upper part of steering column . . . . .	7000-4-4
Main Relay . . . . .	On power distribution box . . . . .	7000-0-1
Motronic Control Unit . . . . .	Under RH side of dash, above glove box . . . . .	7000-4-5
On-Board Computer Module . . . . .	In center console, right of radio face . . . . .	7000-5-3
Power Distribution Box . . . . .	Top front of left front wheel well . . . . .	7000-1-1
Program Selector Switch . . . . .	On center console, to right of shift lever . . . . .	7000-5-4
Start Relay . . . . .	Under LH side of dash, on body electrical bracket . . . . .	7000-4-1
Throttle Position Sensor . . . . .	Top center of engine, behind rubber boot . . . . .	7000-2-3
Throttle Switch . . . . .	Top LH side of engine, below throttle body . . . . .	7000-2-3
Transmission Control Unit . . . . .	Under LH side of dash, above speaker . . . . .	7000-4-3
Transmission Kickdown Switch . . . . .	Passenger compartment, under accelerator pedal	
C103 (4 pin) . . . . .	Under RH side of dash, above glove box . . . . .	7000-4-5
C132 (4 pin) . . . . .	Under RH side of dash, above glove box . . . . .	7000-4-5
C133 (13 pin) . . . . .	Under right side of dash, above glove box	
C152 (8 pin) . . . . .	Under center of car, near transmission	
C200 (10 pin) . . . . .	Under LH side of dash, on LH side of steering column . . . . .	7000-3-2
C209 (7 pin) . . . . .	Under LH side of dash, near body electrical bracket . . . . .	7000-4-2
C214 (2 pin) . . . . .	Under LH side of dash, near steering column	
C301 (2 pin) . . . . .	In center console, ahead of lever	
G103 (Engine Ground) . . . . .	To rear of engine . . . . .	7000-1-6
G104 (Main Body Ground) . . . . .	Inner side of LH fender, near battery . . . . .	7000-1-2
G200 (Front Interior Ground) . . . . .	On dash frame, left of steering column	

(Continued from previous column)

Drive the car with the Program Selector Switch in S	First, second, and third gears are kept selected up to full engine speed. Fourth gear (overdrive) is not selected
Drive the car with the Program Selector Switch in E	Transmission shifts at lower engine speeds and a fourth gear (overdrive) is available

- Refer to System Diagnosis when a result is not normal.

## SYSTEM DIAGNOSIS

- Do the tests listed for your symptom in the Symptom Table below.
- Tests follow the Symptom Table.

(Continued on next page)

(Continued from previous page)

- Perform all tests in order listed in the Symptom Table.

**SYMPTOM TABLE**

SYMPTOM	DO TEST
Transmission Fault Indicator does not flash when the Ignition Switch is turned to RUN and lights when the engine is running	A: Transmission Control Unit 5 Volt Power and Ground Test
Transmission Fault Indicator flashes when the Ignition Switch is turned to RUN and lights with the engine running	C: Engine Speed and Fuel Rate Input Test D: Hydraulic Pressure Regulator and Solenoid Test
Transmission Fault Indicator does not light with the Ignition Switch in RUN and the engine not running	B: Transmission Control Unit Ignition Power Test G: Transmission Fault Indicator Test
Program Selector Switch does not return to E when the engine is cranked	F: Program Selector Switch Return Test
"321" Indicator does not light when the Program Selector Switch is set to "321", but Transmission operates in the 321 mode	H: "321" Indicator Test

(Continued in next column)

(Continued from previous column)

Transmission does not operate in selected program and the Transmission Fault Indicator is off with the engine running	I: Program Selector Switch Continuity Test
Kickdown function is inoperative	K: Kickdown Switch Test
Shift Points are inaccurate or rough and the Transmission Fault Indicator is off with the engine running	L: Gear Input Test M: Throttle Position Sensor and Wide Open Throttle Output Test J: Transmission Speed Sensor Test

- If your symptom does not appear in the Symptom Table, perform all of the following tests.

**A: TRANSMISSION CONTROL UNIT 5 VOLT POWER AND GROUND TEST**

Measure: VOLTAGE At: TRANSMISSION CONTROL UNIT CONNECTOR (Connected) Condition: • Ignition Switch: RUN		
Measure Between	Correct Voltage	For Diagnosis
24 (BR/GN) & Ground	Approximately 5 Volts	See 1
24 (BR/GN) & 19 (BR)	Approximately 5 Volts	See 2
24 (BR/GN) & 5 (BR)	Approximately 5 Volts	See 2
• If all the results are correct, replace the Transmission Control Unit. 1. Go to Test E: Motronic Control Unit Test. 2. Check/repair the BR wire for an open (see schematic).		

**B: TRANSMISSION CONTROL UNIT IGNITION POWER TEST**

Measure: VOLTAGE At: TRANSMISSION CONTROL UNIT CONNECTOR (Connected) Condition: • Ignition Switch: RUN		
Measure Between	Correct Voltage	For Diagnosis
35 (RD/BU) & Ground	Battery	See 1
• If the result is correct, go to the Symptom Table. 1. Check/repair the RD/BU wire to the Main Relay for an open (see schematic).		

(Continued on next page)

## 2460-6 ELECTRONIC TRANSMISSION CONTROL

(Continued from previous page)

### C: ENGINE SPEED AND FUEL RATE INPUT TEST

<b>Measure: VOLTAGE</b> <b>At: TRANSMISSION CONTROL UNIT CONNECTOR (Connected)</b> <b>Condition:</b> <ul style="list-style-type: none"> <li>• Ignition Switch: RUN</li> </ul>		
Measure Between	Correct Voltage	For Diagnosis
11 (WT) & Ground	Greater than 10 Volts	See 1
21 (BK/BU) & Ground	Greater than 10 Volts	See 2
<ul style="list-style-type: none"> <li>• If all the results are correct, go to the Symptom Table.</li> </ul> <ol style="list-style-type: none"> <li> <ul style="list-style-type: none"> <li>• Go to Test E: Motronic Control Unit Test, if the Fuel Rate Gauge does not operate.</li> <li>• Check/repair the WT wire, if the Fuel Rate Gauge operates.</li> </ul> </li> <li> <ul style="list-style-type: none"> <li>• Go to Test E: Motronic Control Unit Test, if the Tachometer does not operate.</li> <li>• Check/repair the BK/BU wire if the Tachometer operates.</li> </ul> </li> </ol>		

### D: HYDRAULIC PRESSURE REGULATOR AND SOLENOID TEST

<b>Measure: RESISTANCE</b> <b>At: TRANSMISSION CONTROL UNIT CONNECTOR (Disconnected)</b>		
Measure Between	Correct Resistance	For Diagnosis
1 (VI) & Ground	Greater than 500 K Ohms	See 1
1 (VI) & 25 (BU)	25 to 46 Ohms	See 2
1 (VI) & 20 (GY)	25 to 46 Ohms	See 2
1 (VI) & 17 (GN)	25 to 46 Ohms	See 2
1 (VI) & 16 (OR)	25 to 46 Ohms	See 2
1 (VI) & 22 (RD)	1.8 to 4.6 Ohms	See 3
<ul style="list-style-type: none"> <li>• If all the results are correct, replace the Transmission Control Unit.</li> </ul> <ol style="list-style-type: none"> <li>Check the wiring from terminals 1, 16, 17, 20, 22, and 25 for shorts to ground (see schematic). Check the Pressure Regulator and Solenoids for a short to ground if wiring is OK. Repair/replace as necessary.</li> <li>Check/repair wire (see schematic) and connector terminal. Replace the Solenoid Valve (see schematic), if wire and connector terminal are OK.</li> <li>Check/repair wire (see schematic) and connector terminal. Replace the Hydraulic Pressure Regulator Solenoid, if wire and connector terminal are OK.</li> </ol>		

### E: MOTRONIC CONTROL UNIT TEST

<b>Measure: VOLTAGE</b> <b>At: MOTRONIC CONTROL UNIT CONNECTOR (Connected)</b> <b>Condition:</b> <ul style="list-style-type: none"> <li>• Ignition Switch: RUN</li> </ul>		
Measure Between	Correct Voltage	For Diagnosis
10 (BR/GN) & Ground	Approximately 5 Volts	See 1
11 (WT) & Ground	Greater than 10 Volts	See 1
21 (BK/BU) & Ground	Greater than 10 Volts	See 1
3 (BR/BK) & Ground	Approximately 5 Volts	See 1
<ul style="list-style-type: none"> <li>• If all the results are correct, check/repair the wire(s) to the Transmission Control Unit for an open(s).</li> </ul> <ol style="list-style-type: none"> <li>Check the wire to the Transmission Control Unit for a short to ground (see schematic). Check/replace the Motronic Control Unit if wire is OK.</li> </ol>		

(Continued on next page)

(Continued from previous page)

**F: PROGRAM SELECTOR SWITCH RETURN TEST**

Measure: VOLTAGE At: PROGRAM SELECTOR SWITCH CONNECTOR C1 (Connected) Condition: • Ignition Switch: START		
Measure Between	Correct Voltage	For Diagnosis
1 (BK) & Ground	Greater than 8 Volts	See 1
1 (BK) & 2 (BR)	Greater than 8 Volts	See 2
• If all the results are correct, replace the Program Selector Switch. 1. Check/repair the BK wire for an open (see schematic). 2. Check/repair the BR wire for an open (see schematic).		

**G: TRANSMISSION FAULT INDICATOR TEST (TABLE 2)**

Measure: VOLTAGE At: TRANSMISSION RANGE DISPLAY CONNECTOR (Disconnected) Condition: • Ignition Switch: RUN		
Measure Between	Correct Voltage	For Diagnosis
1 (RD/WT) & Ground	Greater than 10 Volts	See 1
1 (RD/WT) & 2 (BR)	Greater than 10 Volts	See 2
• If all the voltages are correct, check the bulb and printed circuit board. Replace as necessary. 1. Check/repair the RD/WT wire for an open (see schematic). 2. Check/repair the BR wire for an open (see schematic).		

**H: 321 INDICATOR TEST**

Measure: VOLTAGE At: TRANSMISSION RANGE DISPLAY CONNECTOR (Disconnected) Conditions: • Ignition Switch: RUN • Program Selector Switch: 321		
Measure Between	Correct Voltage	For Diagnosis
3 (BR/WT) & Ground	0 Volts	See 1
12 (GN/BK) & Ground	Greater than 10 Volts	See 2
• If all the results are correct, check the GY wire bulb, printed circuit board, and connector terminals. Repair/replace as necessary. 1. Check/repair the BR/WT wire and the connector terminal (see schematic). 2. Check/repair the GN/BK wire for an open (see schematic).		

**G: TRANSMISSION FAULT INDICATOR TEST (TABLE 1)**

Measure: VOLTAGE At: TRANSMISSION CONTROL UNIT CONNECTOR (Connected) Condition: • Ignition Switch: RUN		
Measure Between	Correct Voltage	For Diagnosis
33 (RD/WT) & Ground	Greater than 10 Volts	See 1
• If the voltage is correct, go to Table 2. 1. Replace the Transmission Control Unit.		

(Continued on next page)



## 2460-8 ELECTRONIC TRANSMISSION CONTROL

(Continued from previous page)

### I: PROGRAM SELECTOR SWITCH CONTINUITY TEST

<b>Measure: RESISTANCE</b> <b>At: TRANSMISSION CONTROL UNIT CONNECTOR (Disconnected)</b> <b>Conditions:</b> <ul style="list-style-type: none"> <li>• Transmission Range Display Connector: Disconnected</li> <li>• Program Selector Switch: E</li> </ul>		
Measure Between	Correct Resistance	For Diagnosis
14 (BR/RD) & 6 (BR)	Approximately 0 Ohms	See 1
• Set Program Selector Switch to 321.		
15 (BR/WT) & 6 (BR)	Approximately 0 Ohms	See 1
• Set Program Selector Switch to S.		
14 (BR/RD) & 6 (BR)	Infinite Ohms	See 2
15 (BR/WT) & 6 (BR)	Infinite Ohms	See 2
<ul style="list-style-type: none"> <li>• If all the results are correct, replace the Transmission Control Unit.</li> </ul> <ol style="list-style-type: none"> <li>1. Check the wires and connector terminals (see schematic). Replace the Program Selector Switch if wires and connector terminals are OK.</li> <li>2. Replace the Program Selector Switch.</li> </ol>		

### J: TRANSMISSION SPEED SENSOR TEST (TABLE 1)

<b>Measure: RESISTANCE</b> <b>At: TRANSMISSION CONTROL UNIT CONNECTOR (Disconnected)</b>		
Measure Between	Correct Resistance	For Diagnosis
8 (BR) & Ground	Greater than 500 K Ohms	See 1
8 (BR) & 27 (WT)	800 Ohms to 1.6 K Ohms	See 2
<ul style="list-style-type: none"> <li>• If all the results are correct, go to Table 2.</li> </ul> <ol style="list-style-type: none"> <li>1. Check/repair the wires from terminals 8 and 27 for shorts to ground (see schematic). Replace the Transmission Speed Sensor if wires are OK.</li> <li>2. Check/repair the wires from terminals 8 and 27 for opens (see schematic). Replace the Transmission Speed Sensor if wires are OK.</li> </ol>		

### J: TRANSMISSION SPEED SENSOR TEST (TABLE 2)

<b>Measure: AC VOLTAGE</b> <b>At: TRANSMISSION CONTROL UNIT CONNECTOR (Disconnected)</b> <b>Conditions:</b> <ul style="list-style-type: none"> <li>• Lift Car (rear wheels must turn freely)</li> <li>• Engine running</li> <li>• Gear Selector: D</li> <li>• Speedometer: 30 km/h (20 mph)</li> </ul>		
Measure Between	Correct Voltage	For Diagnosis
8 (BR) & 27 (WT)	Greater than 3.5 Volts AC	See 1
<ul style="list-style-type: none"> <li>• If the result is correct, replace the Transmission Control Unit.</li> </ul> <ol style="list-style-type: none"> <li>1. Replace the Transmission Output Speed Sensor.</li> </ol>		

### K: KICKDOWN SWITCH TEST

<b>Measure: VOLTAGE</b> <b>At: TRANSMISSION CONTROL UNIT CONNECTOR (Connected)</b> <b>Condition:</b> <ul style="list-style-type: none"> <li>• Ignition Switch: RUN</li> </ul>		
Measure Between	Correct Voltage	For Diagnosis
2 (GY/YL) & Ground	Approximately 5 Volts	See 1
• Depress accelerator pedal to Kickdown.		
2 (GY/YL) & Ground	0 Volts	See 2
<ul style="list-style-type: none"> <li>• If all the results are correct, check the BMW Troubleshooting Manual to verify the problem is not in the Transmission. Replace the Transmission Control Unit, if the problem is not in the Transmission.</li> </ul> <ol style="list-style-type: none"> <li>1. Check the GY/YL wire and Kickdown Switch for a short to ground (see schematic). Replace the Transmission Control Unit if GY/YL wire and Kickdown Switch are OK.</li> <li>2. Check the GY/YL wire for an open (see schematic). Replace the Kickdown Switch if GY/YL wire is OK.</li> </ol>		

(Continued on next page)

(Continued from previous page)

**L: GEAR INPUT TEST**

<b>Measure: VOLTAGE</b> <b>At: TRANSMISSION CONTROL UNIT CONNECTOR (Connected)</b> <b>Conditions:</b> <ul style="list-style-type: none"> <li>• Ignition Switch: RUN</li> <li>• Gear Selector: N (Neutral)</li> </ul>		
Measure Between	Correct Voltage	For Diagnosis
4 (BU/BR) & Ground	Battery	See 1
• Put the Gear Selector in all positions except N (Neutral).		
4 (BU/BR) & Ground	Less than 1 Volt	See 2
• Put the Gear Selector in D (Drive).		
30 (BU/GN) & Ground	Battery	See 1
• Put the Gear Selector in all positions except D (Drive).		
30 (BU/GN) & Ground	Less than 1 Volt	See 2
• Put the Gear Selector in 3 (third gear).		
29 (BU/GY) & Ground	Battery	See 1
• Put the Gear Selector in all positions except 3 (third gear).		
29 (BU/GY) & Ground	Less than 1 Volt	See 2
• Put the Gear Selector in 2 (second gear).		
28 (BU/BK) & Ground	Battery	See 1
• Put the Gear Selector in all positions except 2 (second gear).		
28 (BU/BK) & Ground	Less than 1 Volt	See 2

(Continued in next column)

(Continued from previous column)

• Put the Gear Selector in 1 (first gear).		
18 (BU/RD) & Ground	Battery	See 1
• Put the Gear Selector in all positions except 1 (first gear).		
18 (BU/RD) & Ground	Less than 1 Volt	See 2
• If all the results are correct, go to the Symptom Table.		
1. • If the associated bulb in the Transmission Range Display lights, check/repair the wire to the Automatic Transmission Range Switch for an open (see schematic).		
• If the associated bulb in the Transmission Range Display does not light, check/repair wire from the Automatic Transmission Range Switch, and the Automatic Transmission Range Switch (see schematic).		
2. Check/repair the wire for a short to voltage and the Automatic Transmission Range Switch (see schematic).		

**M: THROTTLE POSITION SENSOR AND WIDE OPEN THROTTLE OUTPUT TEST**

<b>Measure: VOLTAGE</b> <b>At: TRANSMISSION CONTROL UNIT CONNECTOR (Connected)</b> <b>Condition:</b> <ul style="list-style-type: none"> <li>• Ignition Switch: RUN</li> </ul>		
Measure Between	Correct Voltage	For Diagnosis
31 (BR/BK) & Ground	Approximately 5 Volts	See 1
9 (OR/BK) & Ground	Approximately 5 Volts	See 2
9 (OR/BK) & 10 (BR)	Approximately 5 Volts	See 3
• Operate Throttle through its full range.		
7 (YL) & 10 (BR)	.7 Volts (Throttle closed) increasing evenly to 4.77 Volts (Throttle fully opened)	See 4
• Depress throttle pedal to the floor.		
31 (BR/BK) & Ground	Approximately .3 Volts	See 2

(Continued on next page)

(Continued from previous page)

- If all the results are correct, go to the Symptom Table.
- 1. Go to Test E: Motronic Control Unit Test.
- 2. Replace the Transmission Control Unit.
- 3. Check/repair BR wire to terminal 6 of the Transmission Control Unit for an open. Check the connector terminals.
- 4. Check/repair the wiring to the Throttle Position Sensor. Adjust the Throttle Position Sensor if wiring is OK (See note). Replace the Throttle Position Sensor if adjustment does not correct the problem.

**NOTE:** The highest voltage at full open position should be .22 volts less than the stabilized voltage. Adjust Throttle Position Sensor accordingly.

### CIRCUIT OPERATION

By operating the Program Selector Switch, the driver can select 3 different transmission modes. When the Program Selector Switch is set to E (Economy), the Economy Input (terminal 14) in the Transmission Control Unit is grounded through terminal 6. The Economy Mode is designed for smooth, refined shift points and low fuel consumption. A fourth gear, or overdrive ratio, is available in the Economy Mode to reduce engine speed and noise level. When the Program Selector Switch is set to 321, the 321 Input (terminal 15), in the Transmission Control Unit, is grounded through terminal 6 and the 321 Indicator lights. The Transmission does not shift up or down and will operate in the selected gear only. When the Program Selector Switch is set to S, voltage is present at the Economy and 321 Inputs in the

Transmission Control Unit. Fourth gear is not selected and first, second and third gears are kept selected up to full engine speed. The Program Selector Switch is designed to return to E when the engine is cranked. When the engine is cranked, voltage is applied to the coil in the Program Selector Switch through the Ignition Switch and the Start Relay. The coil energizes and the Program Selector returns to E.

The Transmission Control Unit monitors engine speed (terminal 21), fuel rate (terminal 11), Throttle position (terminal 7), road speed (terminals 8 and 27), Kickdown signal (terminal 2), Gear Selector position (terminals 4, 30, 29, 28 and 18) and Program Selector Switch position (terminals 14 and 15). The Transmission Control Unit's electronic processing circuit compares this information with the program data to establish the correct gear and smooth shift points, by controlling the Shift Valve Solenoids and the Hydraulic Pressure Regulator.

The Transmission Fault Indicator will light with the engine running, if a problem with the control system occurs. When a fault is detected, the vehicle can only be driven in third and reverse gears. Neutral and Park also retain their functions. Voltage to the transmission (terminal 1) is not present when a fault is detected.

The Reverse Gear Inhibit Lock Solenoid prevents the driver from selecting reverse above 5 mph.

# 3435-0 BRAKE LINING WARNING

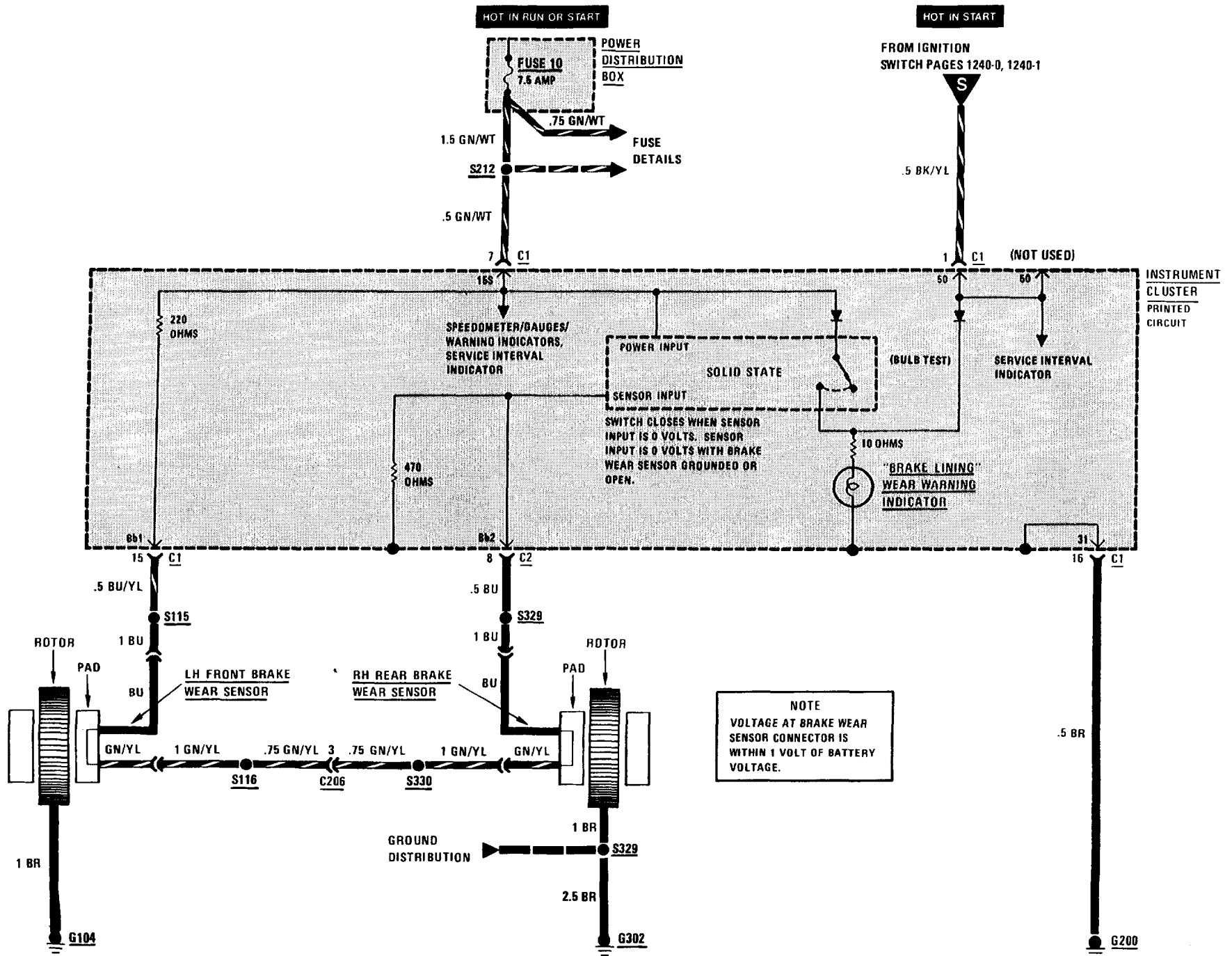

# 3450-0 ANTILOCK BRAKING SYSTEM (ABS)

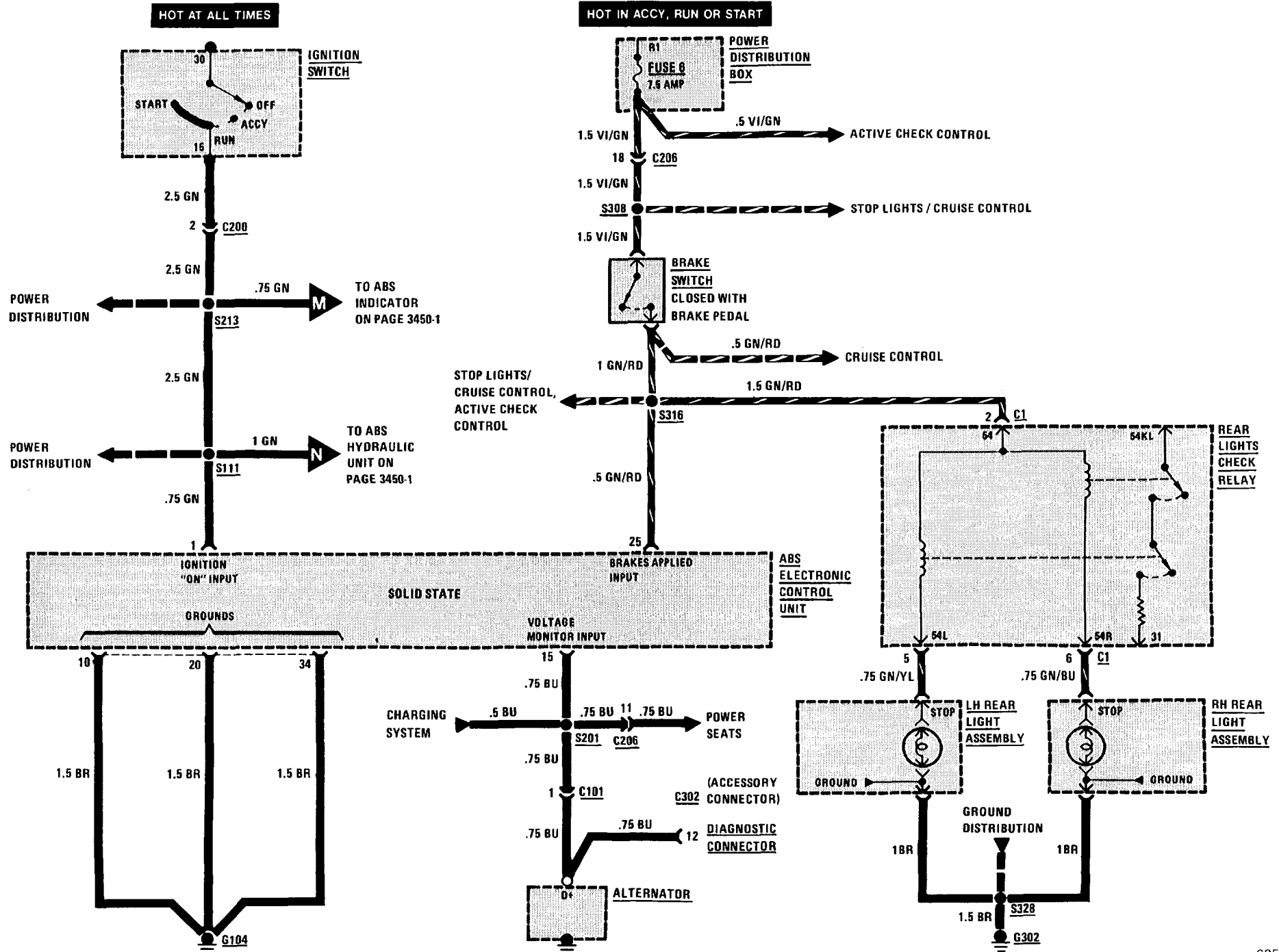

# ANTILOCK BRAKING SYSTEM (ABS) 3450-1

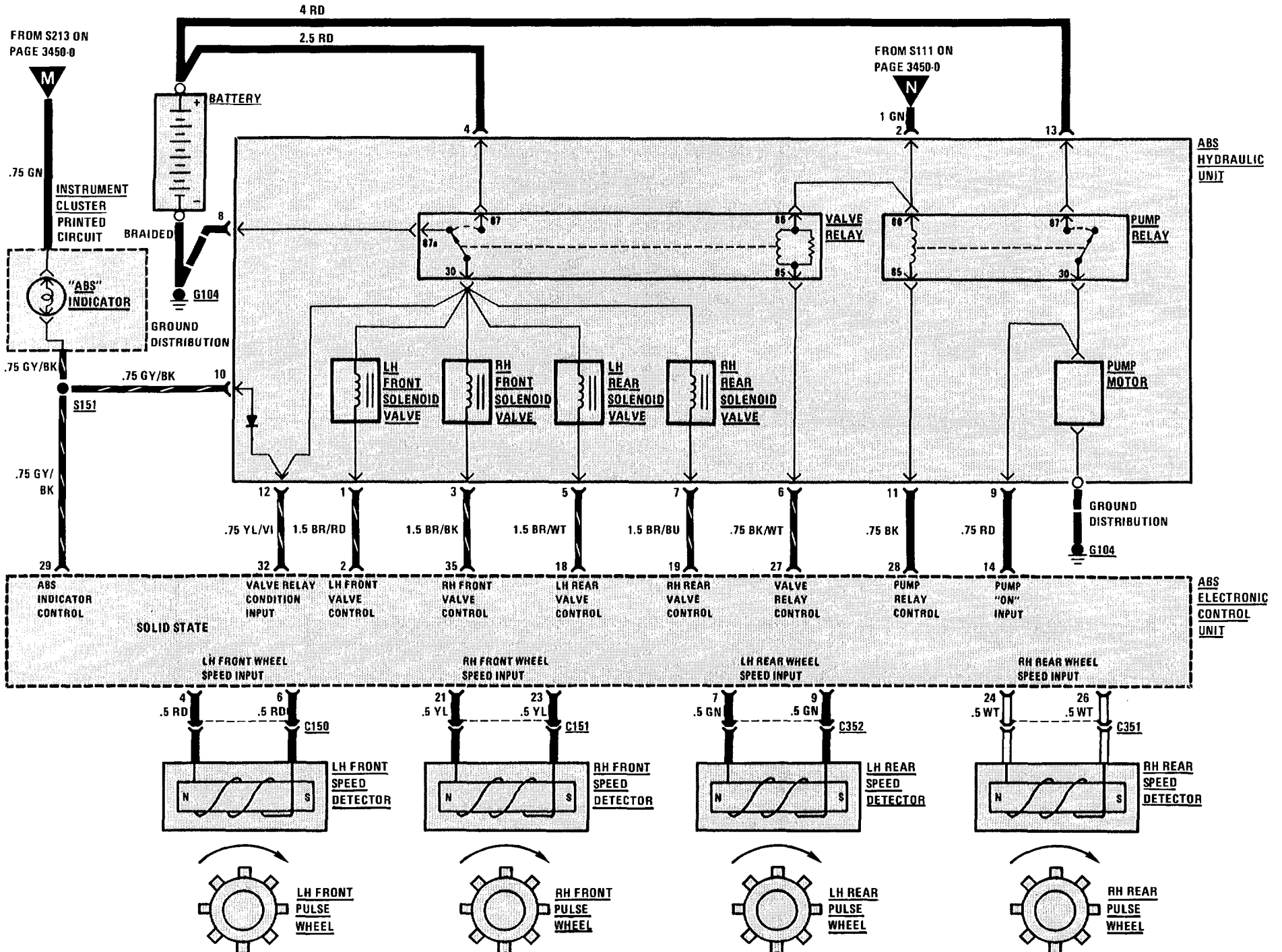

# 5116-0 POWER MIRRORS

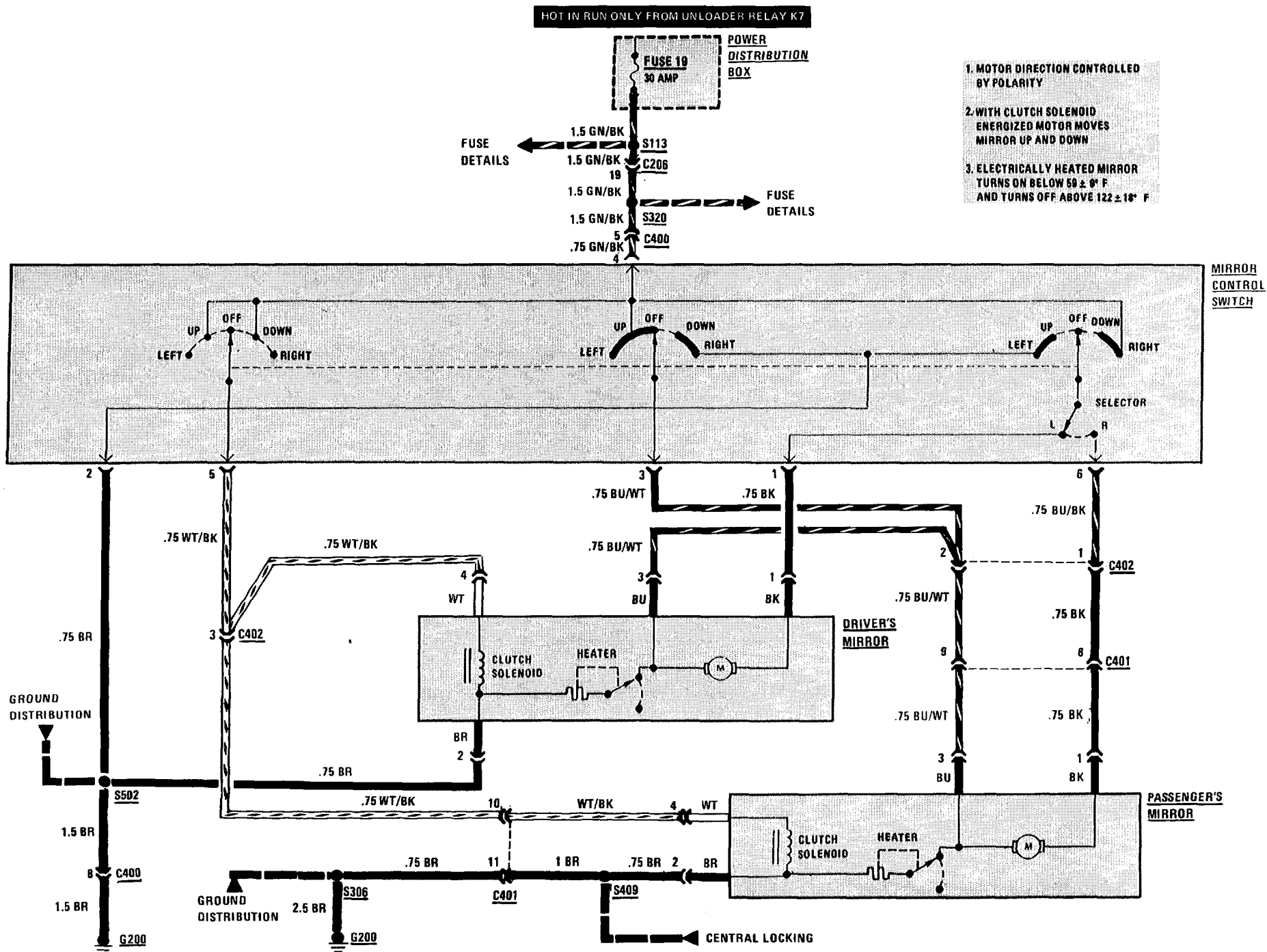

# 5126-0 CENTRAL LOCKING

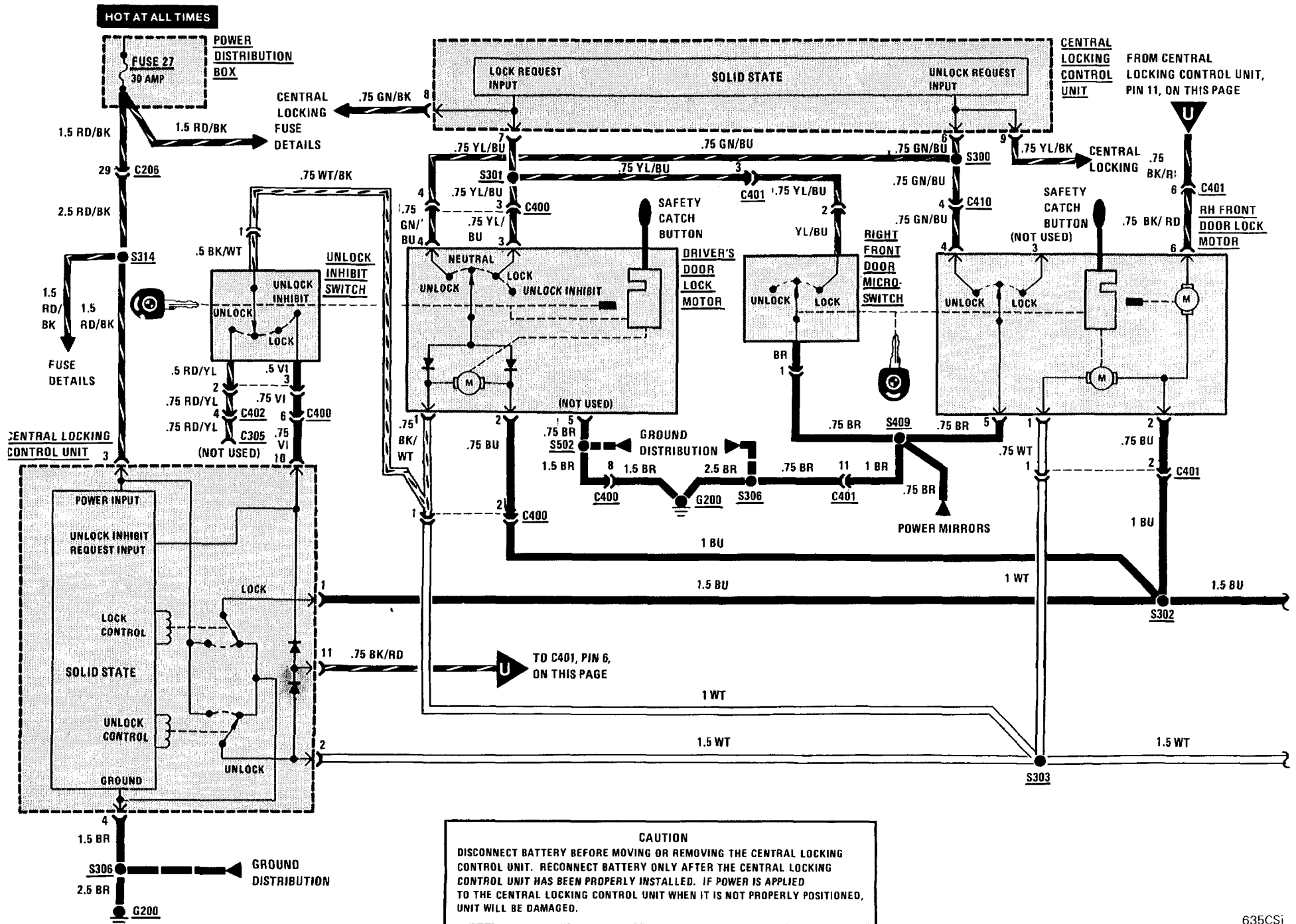



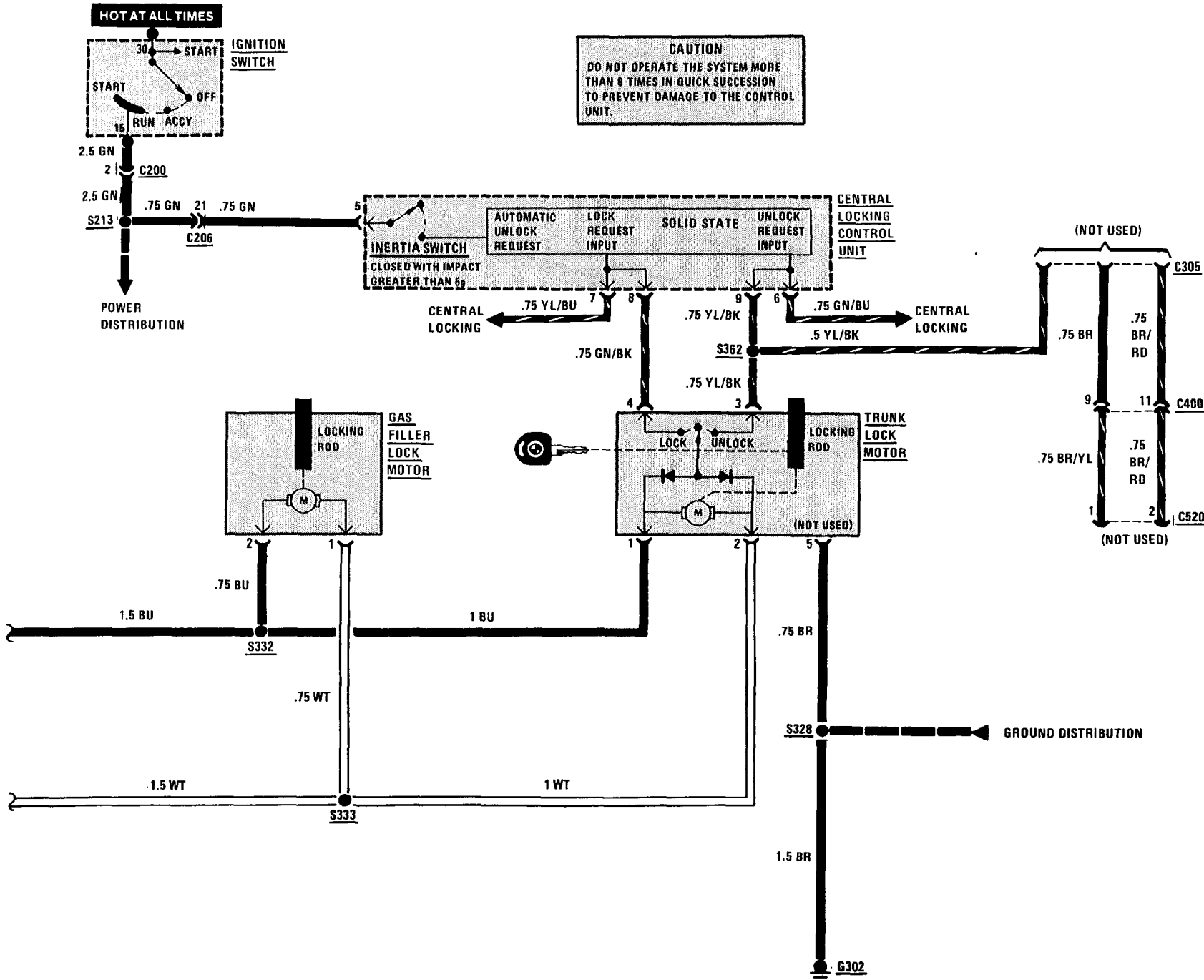

## **5126-2 CENTRAL LOCKING**

---

### **TROUBLESHOOTING HINTS**

1. Check Fuse 27 by operating the On-Board Computer.

### **SYSTEM CHECK**

- Operate controls in sequence listed in the System Check Table.
- Refer to Repair Action for the Response received (Tests follow the System Check Table).
- After any repair, repeat System Check to verify proper system operation.

**NOTE:** Before replacing any system component, check all connectors, splices, and wiring to that component.

**SYSTEM CHECK TABLE**

<b>OPERATION</b>	<b>RESPONSE</b>	<b>REPAIR ACTION</b>
1. Insert the key in the Driver's door and turn to LOCK	All doors lock	None, proceed to Operation 2
	Some doors lock	Repair/replace the suspect Door Lock Motor circuit
	No doors lock	Proceed to Operation 4
2. Turn the key to UNLOCK INHIBIT (clockwise until key is horizontal)	All doors double lock (Safety Catch Buttons cannot be pulled up by hand)	None, proceed to Operation 3
	Driver's door double locks and only some of the other doors double lock	Repair/replace the suspect Door Lock Motor
	Driver's door double locks but all the other doors do not double lock	Perform Test B
	Driver's door does not double lock	Mechanical problem, see BMW Troubleshooting Manual
3. Turn the key to UNLOCK	All doors unlock	None, proceed to Operation 4
	Some doors unlock	Repair/replace the suspect Door Lock Motor circuit
	No doors unlock	Proceed to Operation 5
4. Insert the key in the Passenger's door and turn to LOCK	All doors lock	If the doors did not lock in Operation 1, repair/replace the Driver's Door Lock Switch, otherwise proceed to Operation 5
	Some doors lock	Repair/replace the suspect Door Lock Motor circuit
	No doors lock	If all the doors locked in Operation 1, repair/replace the Right Front Door Microswitch. If the doors did not lock in Operation 1, perform Test A
5. Insert the key in the Passenger's door and turn to UNLOCK	All doors unlock	If all the doors did not unlock in Operation 3, repair/replace the Driver's Door Lock Switch, otherwise proceed to Operation 6
	Some doors unlock	Repair/replace the suspect Door Lock Motor
	No doors unlock	If all the doors unlocked in Operation 3, repair/replace the Passenger's Door Lock Switch. If the doors did not unlock in Operation 3, perform Test C
6. Get in the car and close and lock all doors Turn the Ignition Switch to RUN	Doors remain locked	None, proceed to Operation 7
	Doors unlock	Repair/replace the Central Locking Control Unit

## 5126-4 CENTRAL LOCKING

### SYSTEM CHECK TABLE (CONT'D)

OPERATION	RESPONSE	REPAIR ACTION
7. Get out of the car Insert the key in the Driver's door and turn to LOCK Unlock each of the doors by pulling up the Safety Catch Buttons	All doors can be unlocked	None, proceed to Operation 8
	All doors remain secure	Disconnect the connector from the Central Locking Control Unit and check for a short to ground in the BK wires at terminal 11. • If short to ground is not present, replace the Central Locking Control Unit • If short to ground is present isolate wiring from Door Lock Motors one at a time to find short
8. Insert the key in the Trunk Cylinder Switch. Turn the key to LOCK	Trunk locks	None, proceed to Operation 9
	Trunk does not lock	If the doors lock, repair/replace the Trunk Lock Motor Circuit or Trunk Lock Motor. If the doors do not lock, repair/replace the Trunk Switch. Repair/replace the Central Locking Control Unit if the Trunk Switch Circuit is OK
9. Turn the key to UNLOCK	Trunk unlocks	None, proceed to Operation 10
	Trunk does not unlock	If the doors unlock, repair/replace the Trunk Lock Motor circuit or Trunk Lock Motor. If the doors do not unlock, repair/replace the Trunk Switch. Repair/replace the Central Locking Control Unit if the Trunk Switch Circuit is OK
10. Turn the key back to LOCK	Gas Filler locks	None, proceed to Operation 11
	Gas Filler does not lock	Repair/replace the Gas Filler Lock Motor circuit
11. Turn the key to UNLOCK	Gas Filler unlocks	None
	Gas Filler does not unlock	Repair/replace the Gas Filler Lock Motor circuit

- If all results are normal, the system is OK.

**A: CONTROL UNIT LOCK TEST  
(TABLE 1)**

<b>Measure: VOLTAGE</b>		
<b>At: CONTROL UNIT CONNECTOR (Connected)</b>		
Measure Between	Correct Voltage	For Diagnosis
3 (RD/BK) & Ground	Battery	See 1
3 (RD/BK) & 4 (BR)	Battery	See 2
<ul style="list-style-type: none"> <li>• If the voltages are correct, proceed to Table 2.</li> </ul> <ol style="list-style-type: none"> <li>1. Check the RD/BK wire for an open.</li> <li>2. Check the BR wire for an open to ground (see schematic).</li> </ol>		

**A: CONTROL UNIT LOCK TEST  
(TABLE 2)**

<b>Connect: A FUSED JUMPER</b>		
<b>At: CONTROL UNIT CONNECTOR (Connected)</b>		
Jumper Between	Correct Result	For Diagnosis
7 (YL/BU) & Ground	Doors lock	See 1
<ul style="list-style-type: none"> <li>• If the result is correct, repair/replace the switches and related wiring (see schematic).</li> </ul> <ol style="list-style-type: none"> <li>1. Proceed to Table 3.</li> </ol>		

**A: CONTROL UNIT LOCK TEST  
(TABLE 3)**

<b>Connect: FUSED JUMPERS</b>		
<b>At: CONTROL UNIT CONNECTOR (Disconnected)</b>		
Jumper Between	Correct Result	For Diagnosis
1 (BU) & 3 (RD/BK) 2 (WT) & 4 (BR)	Doors lock	See 1
<ul style="list-style-type: none"> <li>• If the result is correct, replace the Central Locking Control Unit.</li> </ul> <ol style="list-style-type: none"> <li>1. Check the BU wire to splice S302 and the WT wire to splice S303 for opens (see schematic).</li> </ol>		

**B: UNLOCK INHIBIT TEST**

<b>Connect: A FUSED JUMPER</b>		
<b>At: CONTROL UNIT CONNECTOR (Connected)</b>		
Jumper Between	Correct Result	For Diagnosis
10 (VI) & Ground	Doors double lock	See 1
<ul style="list-style-type: none"> <li>• If the result is correct, check the VI, and WT/BK wires for opens (see schematic). Replace the Unlock Inhibit Switch if the wires and connections are OK.</li> </ul> <ol style="list-style-type: none"> <li>1. Check the BK/RD wires for opens (see schematic). Replace the Central Locking Control Unit, if the wires and connections are OK.</li> </ol>		

**C: CONTROL UNIT UNLOCK TEST**

<b>Connect: A FUSED JUMPER</b>		
<b>At: CONTROL UNIT CONNECTOR (Connected)</b>		
Jumper Between	Correct Result	For Diagnosis
6 (GN/BU) & Ground	Doors unlock	See 1
<ul style="list-style-type: none"> <li>• If the result is correct, repair/replace the switches and related wiring (see schematic).</li> </ul> <ol style="list-style-type: none"> <li>1. Replace the Central Locking Control Unit.</li> </ol>		

### CIRCUIT DESCRIPTION

The Central Locking System is controlled by the Central Locking Control Unit. This unit senses when a lock switch is moved by a key, and sends the appropriate signal to drive the Motors. The Central Locking Control Unit controls the Door Locks, Gas Filler Lock and Trunk Lock. The unit also has an Inertia Switch which closes on impact greater than 5g. If in RUN or START, the locks are then unlocked.

#### Lock

When the Key is inserted into a lock and turned clockwise, the lock switch moves to LOCK and grounds terminal 7 of the Central Locking Control Unit. The unit then activates the Lock Relay and applies voltage from Fuse 27 to the Lock Motor, which is grounded through the WT wire, Central Locking Control Unit and BR wire. The Lock Motor then pulls the lock down. The door locks also control the Trunk Lock and Gas Filler Lock.

#### Unlock

When the key is turned counterclockwise, terminal G of the Central Locking Control Unit is grounded through the Lock Switch. The Central Locking Control Unit then activates the Unlock Relay and applies voltage from Fuse 27, through the WT wire to the Lock Motor. The motor is grounded through the BU wire, Central Locking Control Unit, and BR wire. The polarity is reversed and the motor pushes the lock up.

#### Unlock Inhibit

When the key is inserted into the Driver's Lock and turned clockwise past the LOCK position, the Unlock Inhibit mechanism is

engaged. This mechanically inserts a bar into the driver's lock and prevents unlocking through use of the Safety Catch Button. When in the Unlock Inhibit position, ground is applied to the Unlock Inhibit motors in the other lock units. The Central Locking Control Unit is grounded at terminal 10 and then activates the Lock Relay. Voltage is applied to the Unlock Inhibit motors through the BU wire. They are now activated and engage the other Unlock Inhibit mechanisms. The direction of the motors is reversed when the doors are unlocked (see Unlock).

#### Trunk Lock

The Trunk Lock operates in a manner similar to the Door Locks.

# 5133-0 POWER WINDOWS

## EARLY PRODUCTION

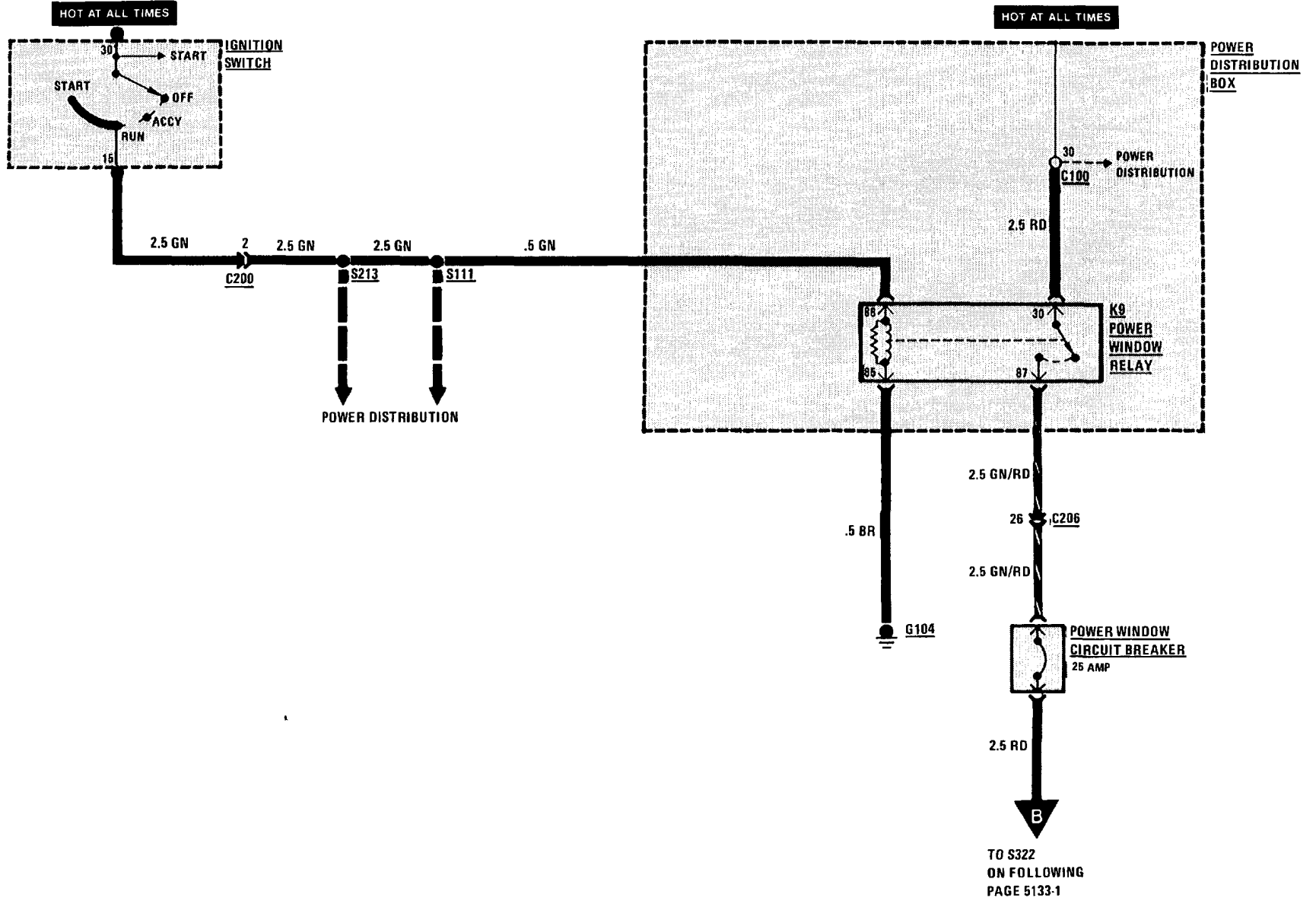

EARLY PRODUCTION

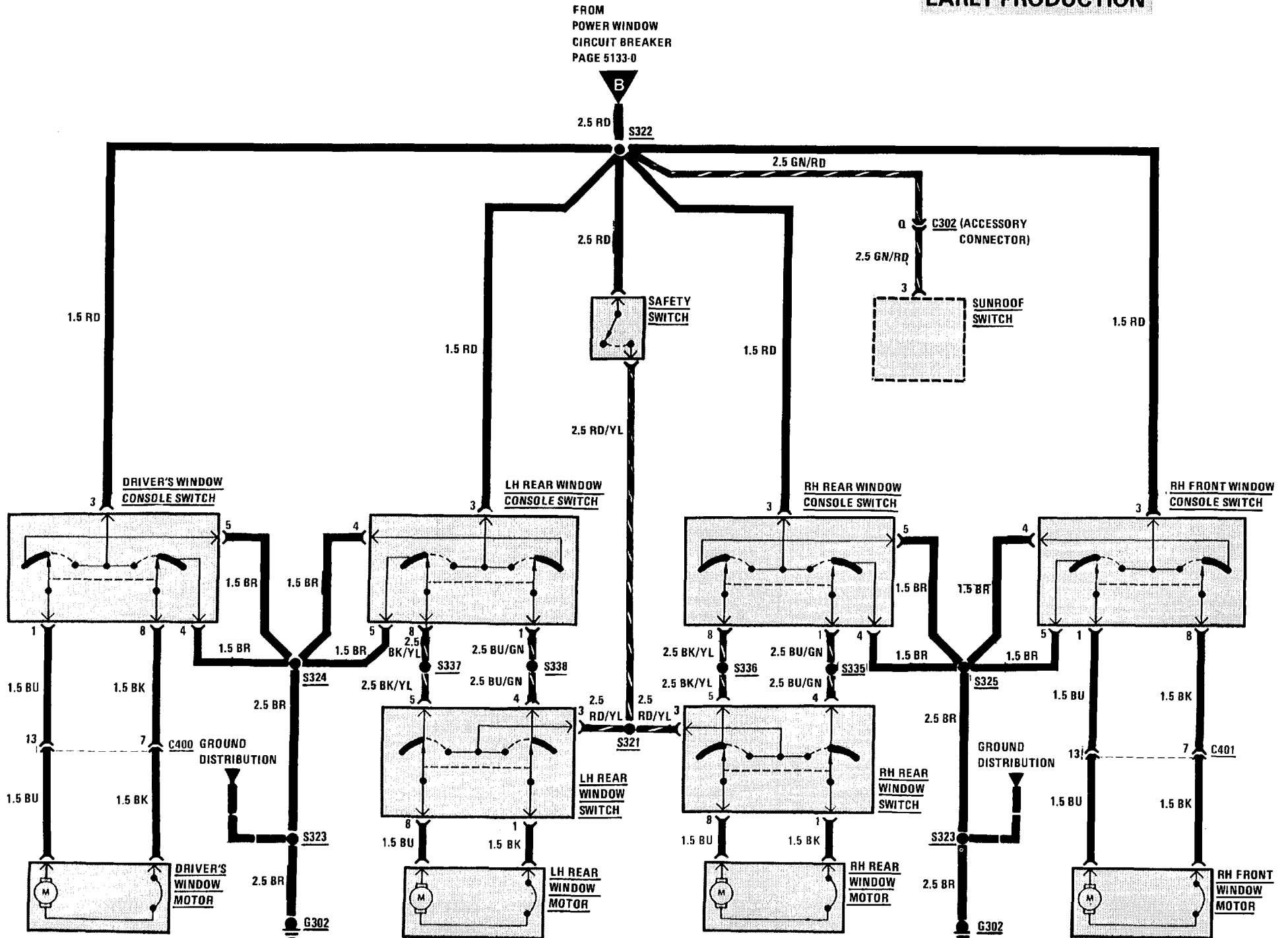



# 5133-2 POWER WINDOWS

## LATE PRODUCTION

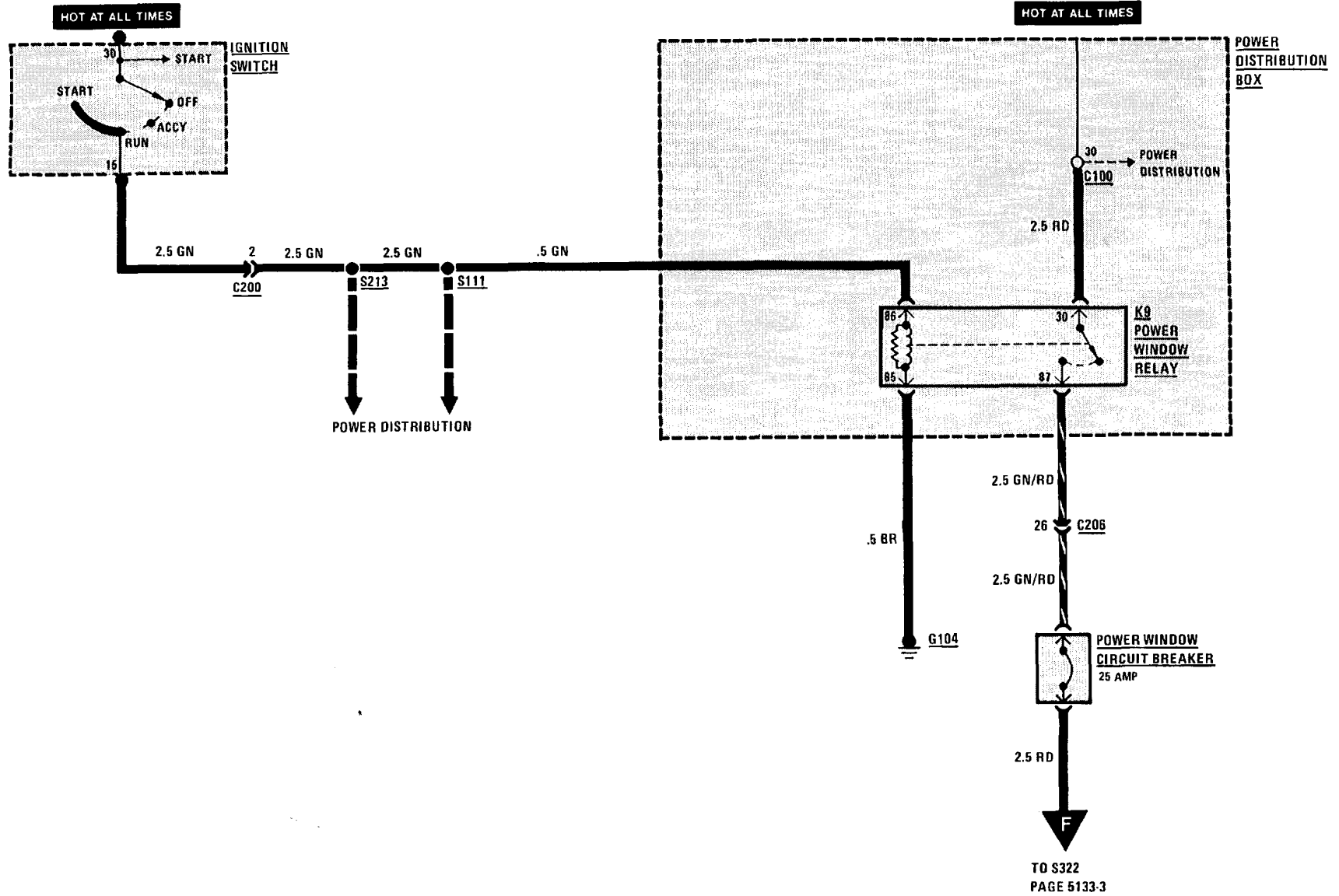

LATE PRODUCTION

FROM POWER WINDOW CIRCUIT BREAKER  
PAGE 5133-2

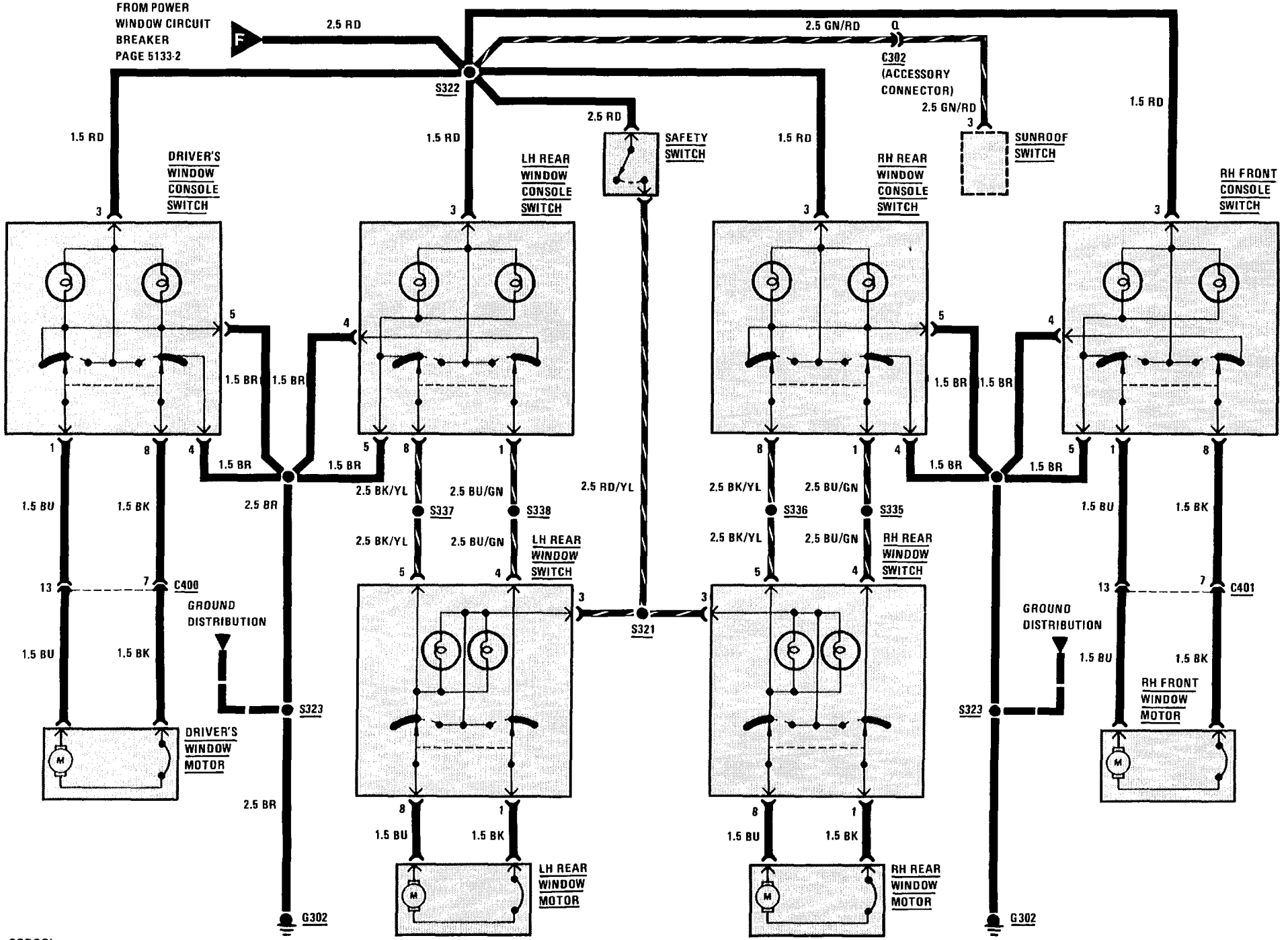

# 5200-0 POWER SEATS

## DRIVER'S MEMORY SEAT

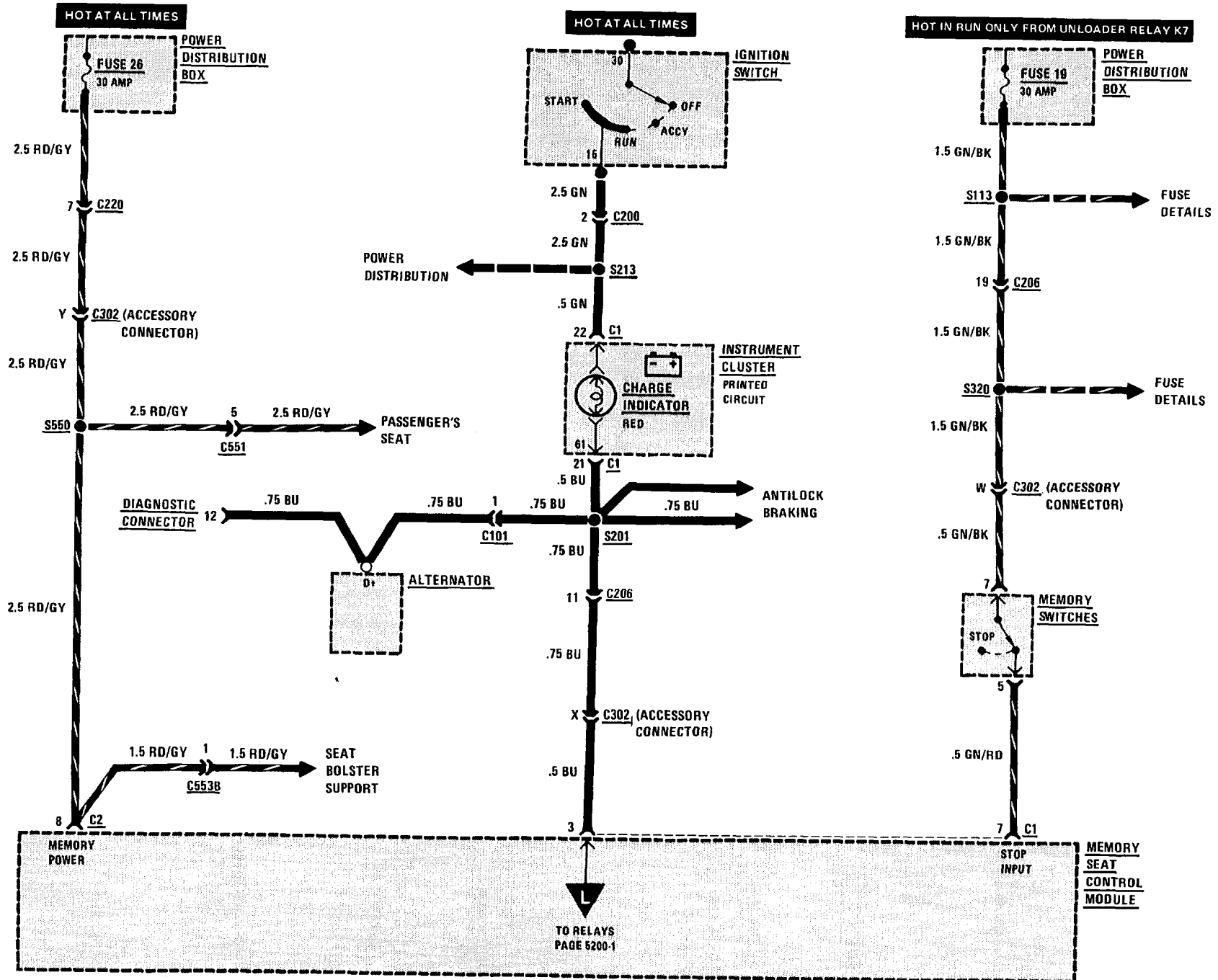

MEMORY SEAT CONTROL MODULE

DRIVER'S MEMORY SEAT

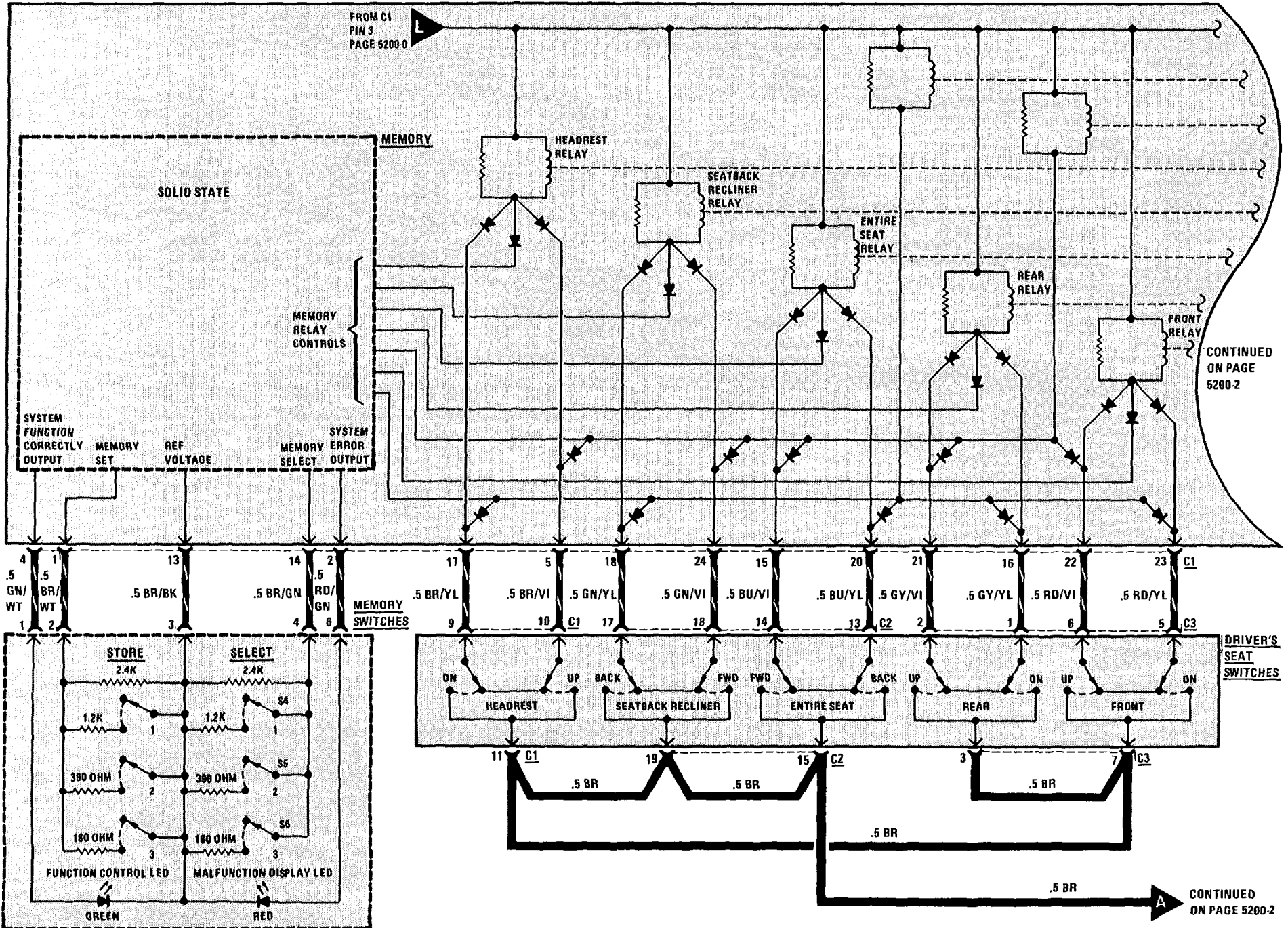

CONTINUED ON PAGE 5200-2

DRIVER'S SEAT SWITCHES

CONTINUED ON PAGE 5200-2

# 5200-2 POWER SEATS

## DRIVER'S MEMORY SEAT

CONTINUED  
FROM PAGE  
5200-1

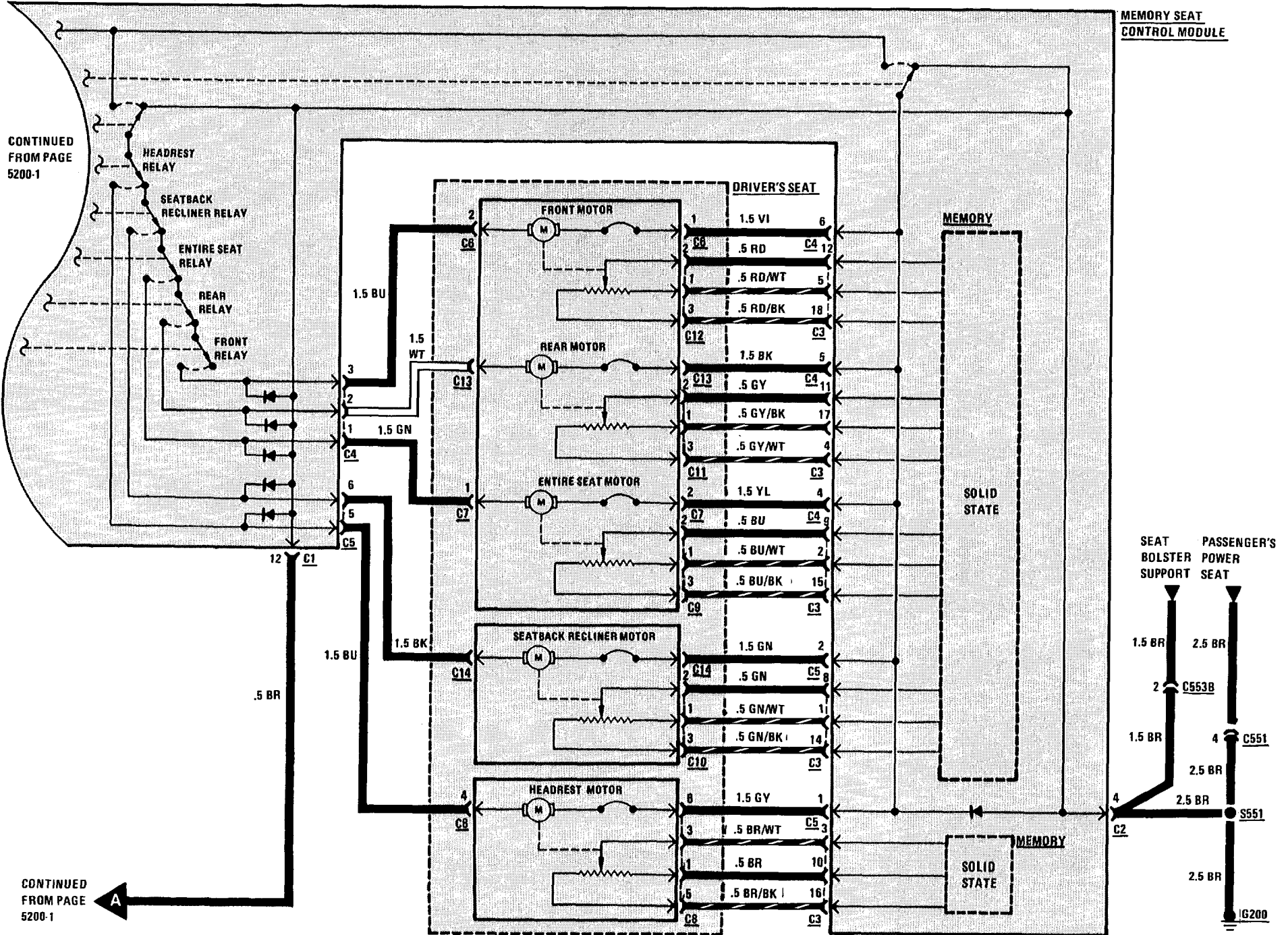

CONTINUED  
FROM PAGE  
5200-1



PASSENGER'S SEAT

PASSENGER'S SEAT CONTROLLER

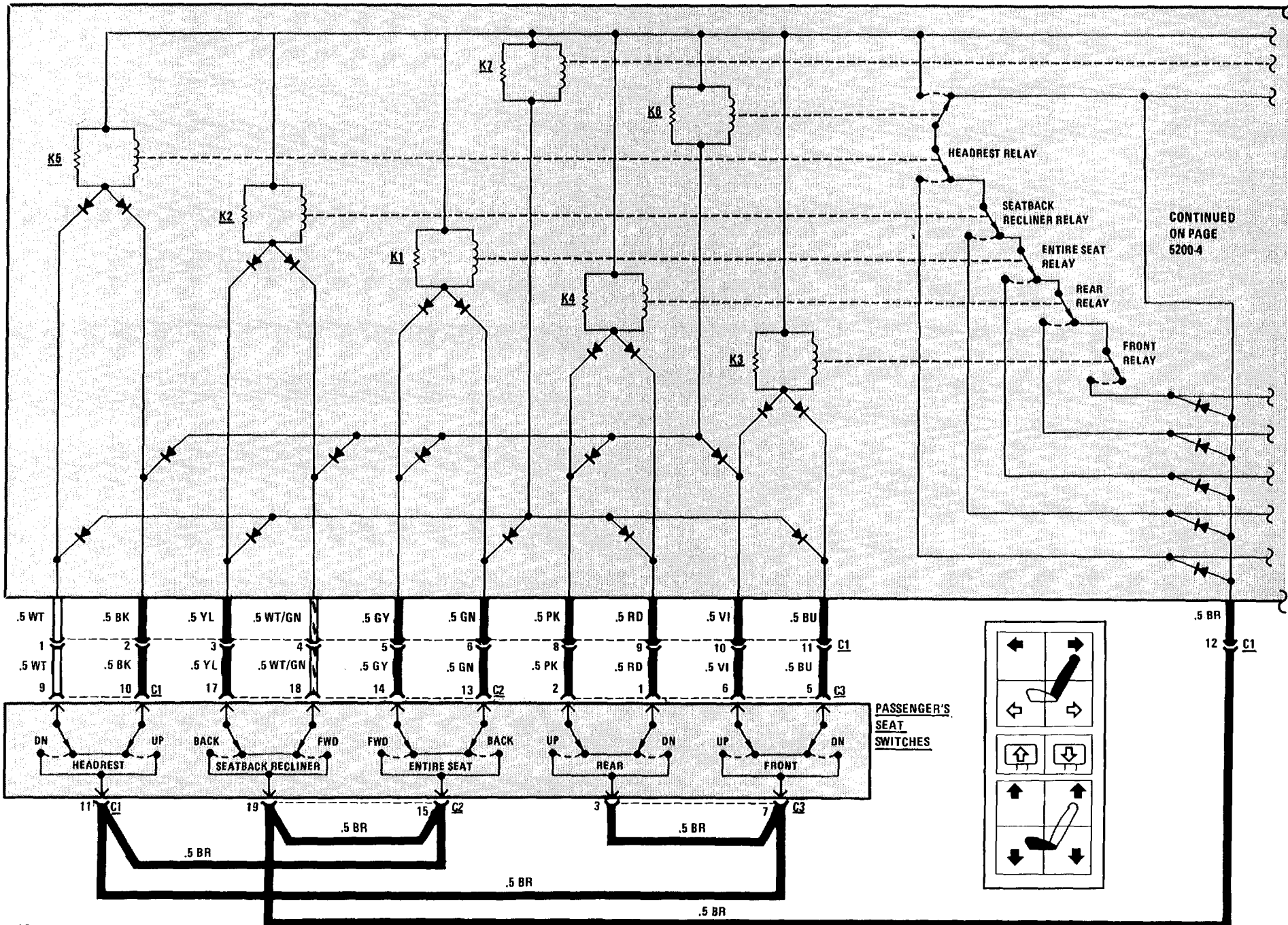

CONTINUED ON PAGE 5200-4

PASSENGER'S SEAT SWITCHES

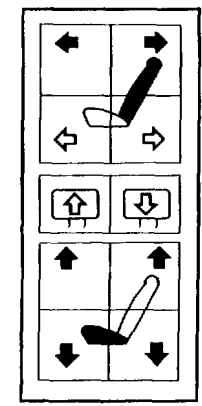

PASSENGER'S SEAT

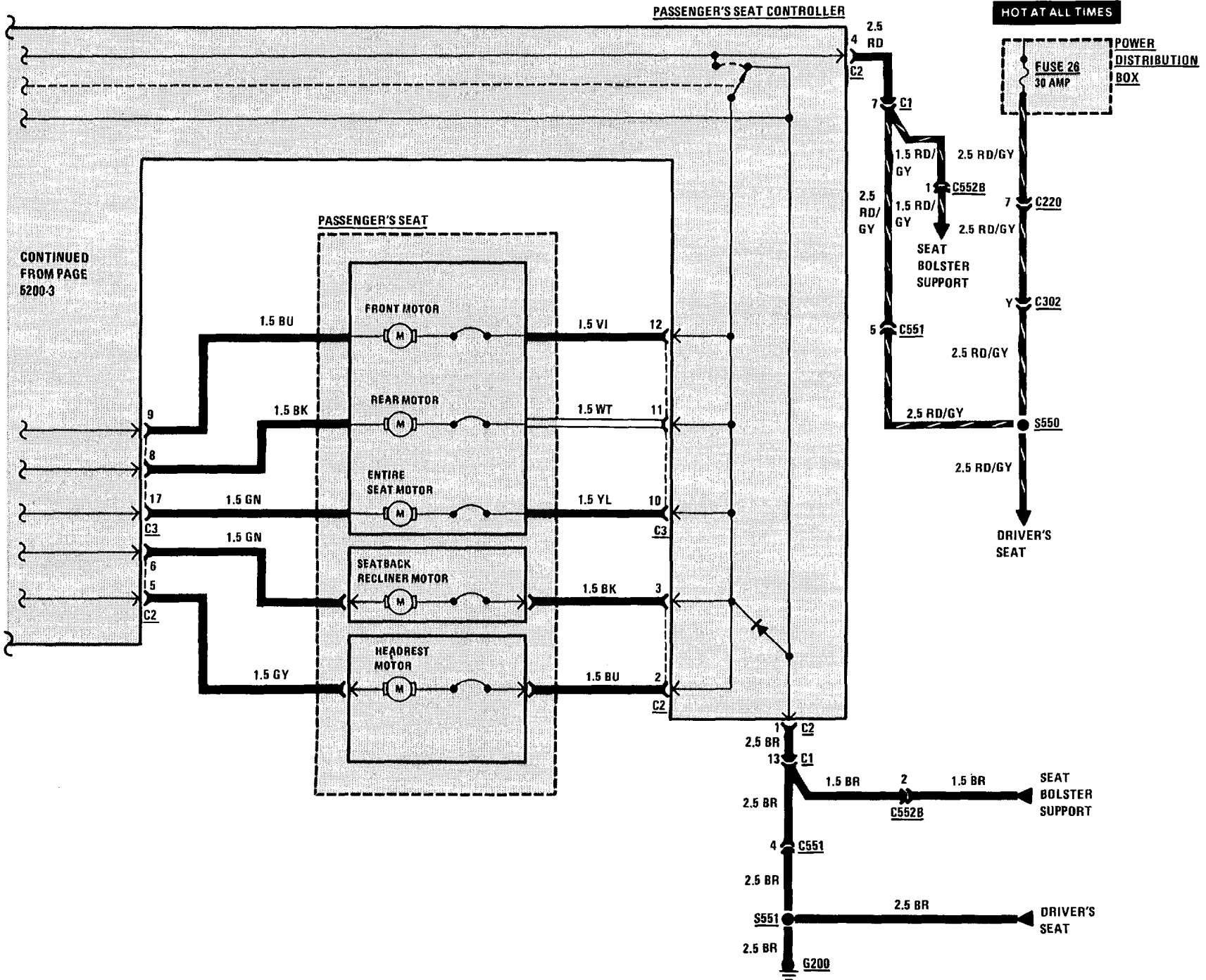

SEAT BOLSTER SUPPORT

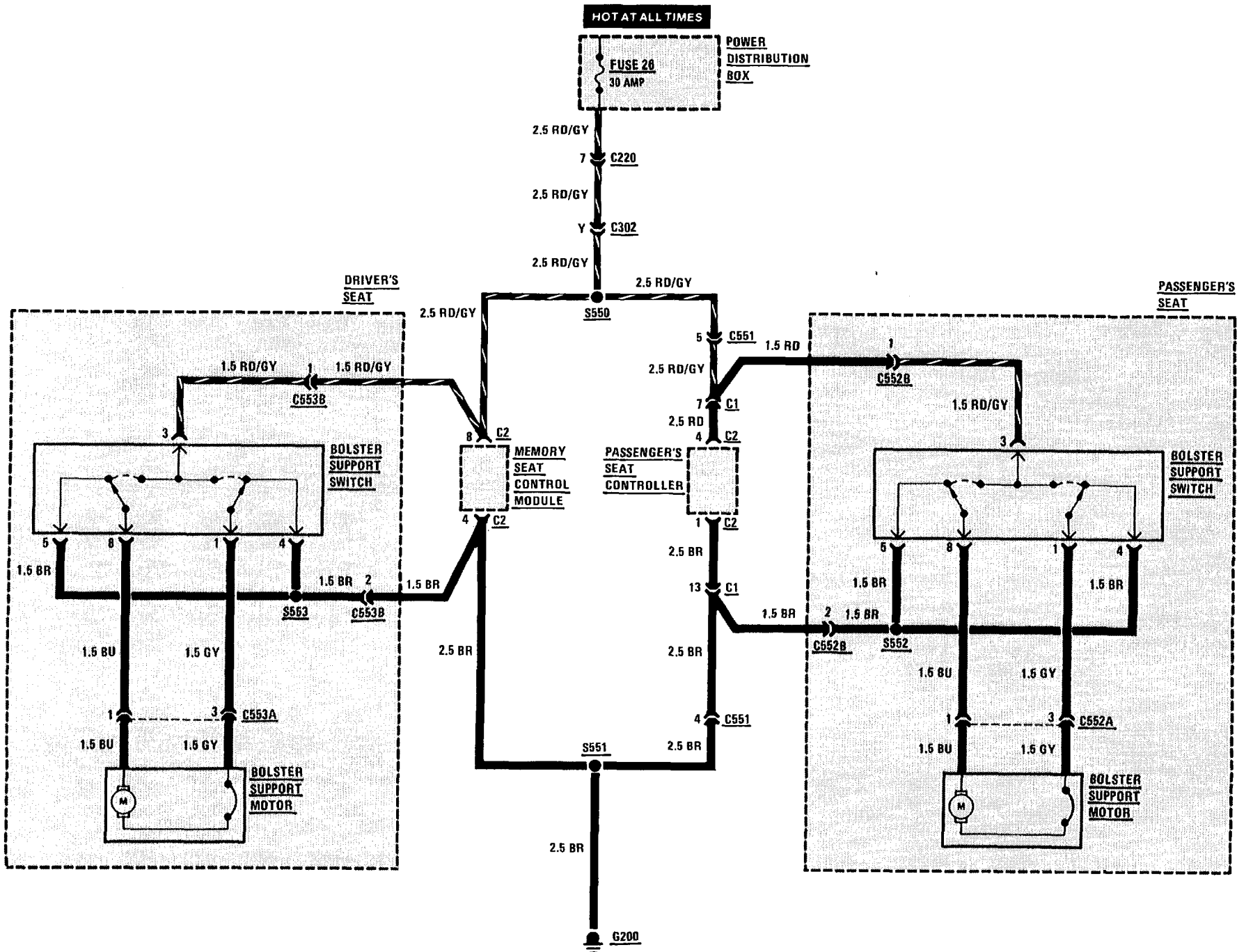



EARLY PRODUCTION

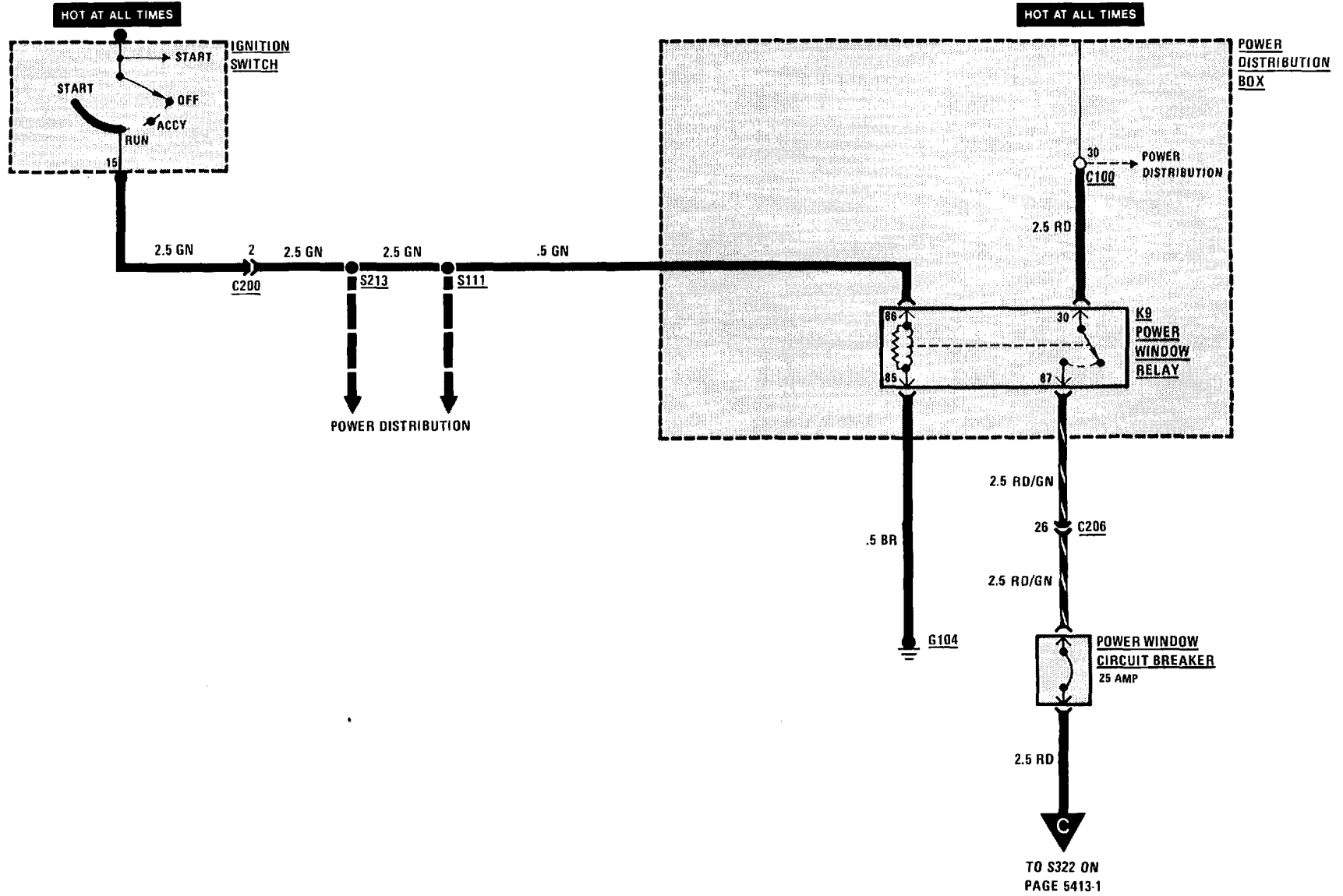

EARLY PRODUCTION

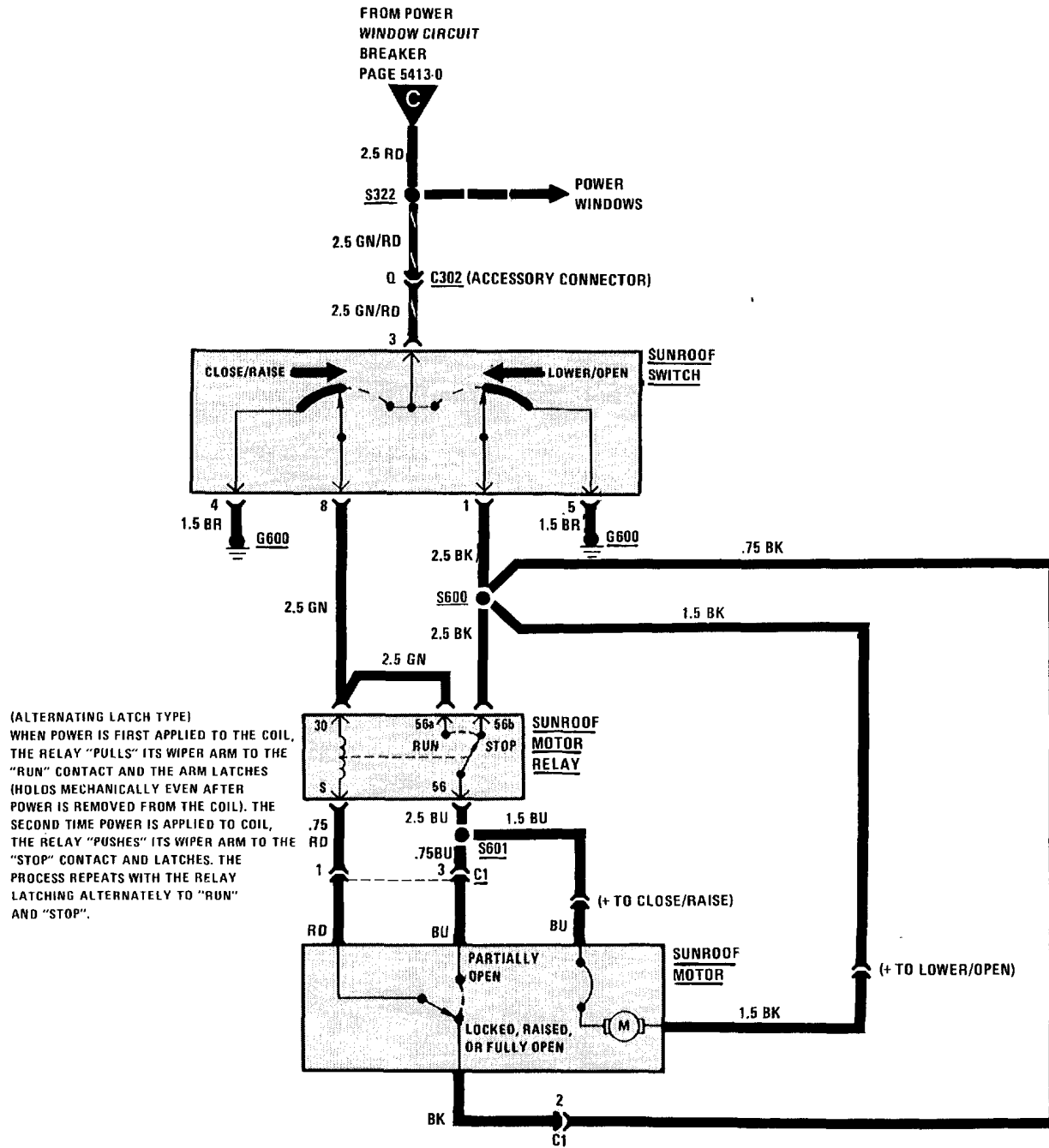

# 5413-2 SUNROOF

## LATE PRODUCTION

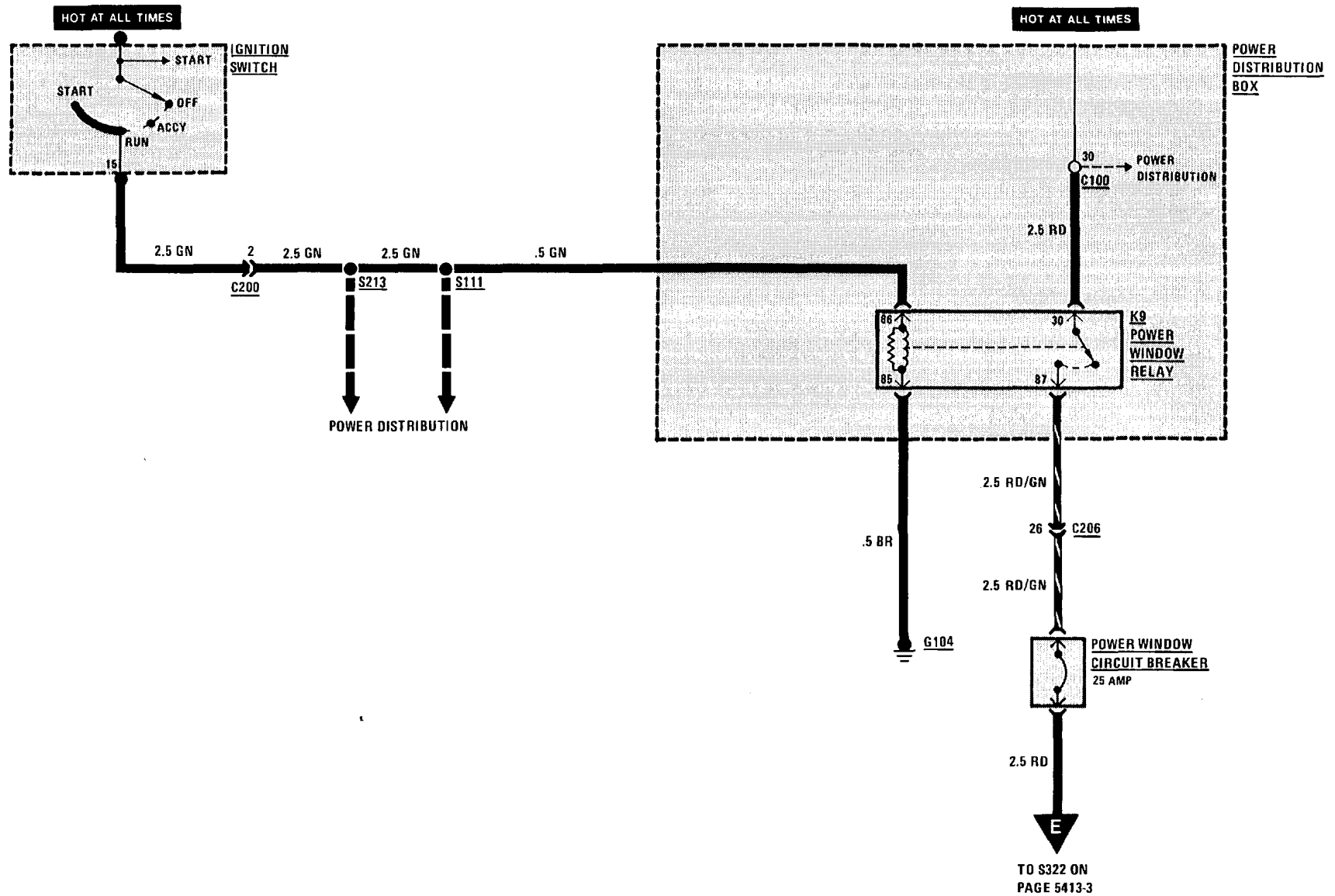

LATE PRODUCTION

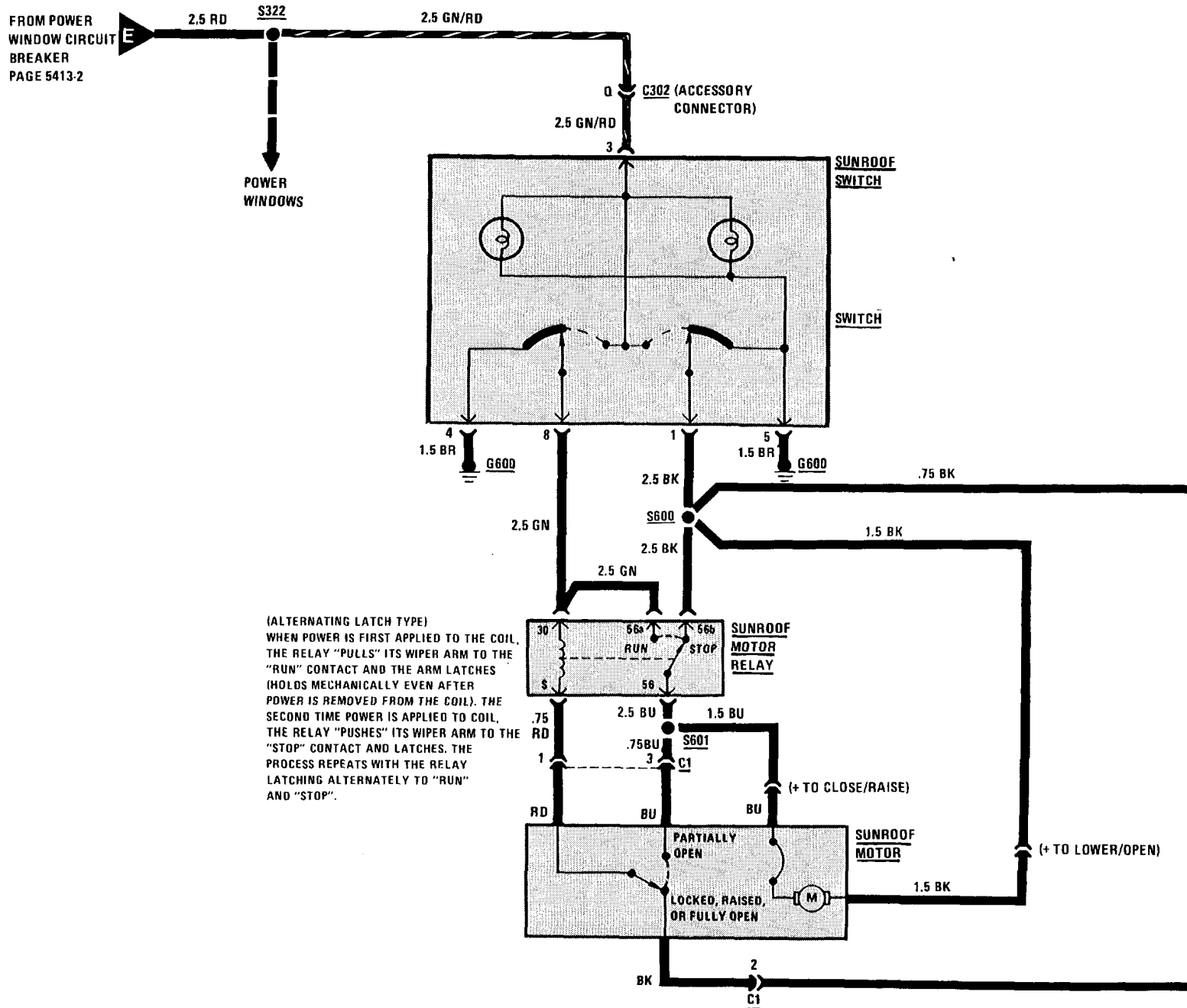

**HORN**

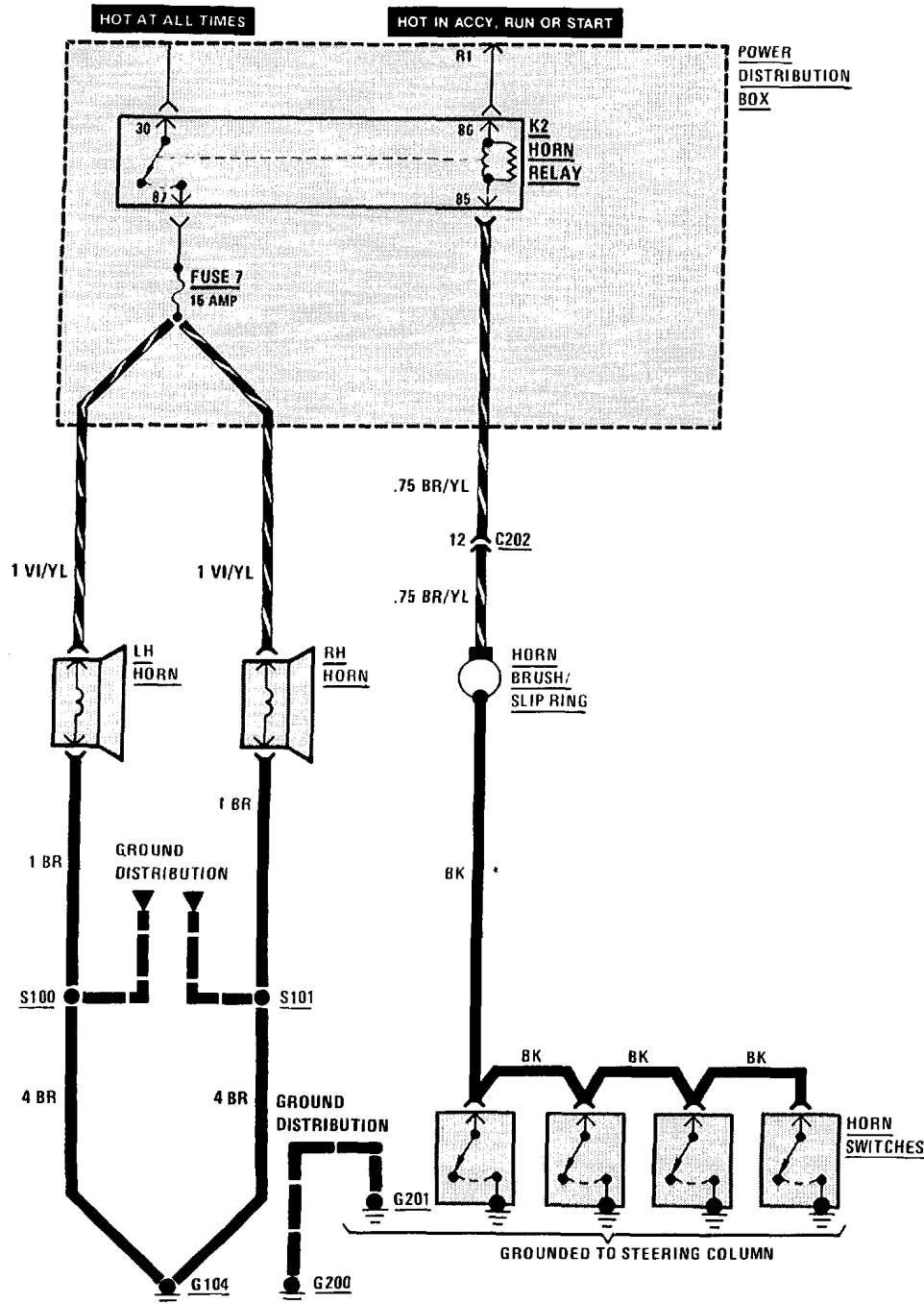

**HEATED DOOR LOCK**

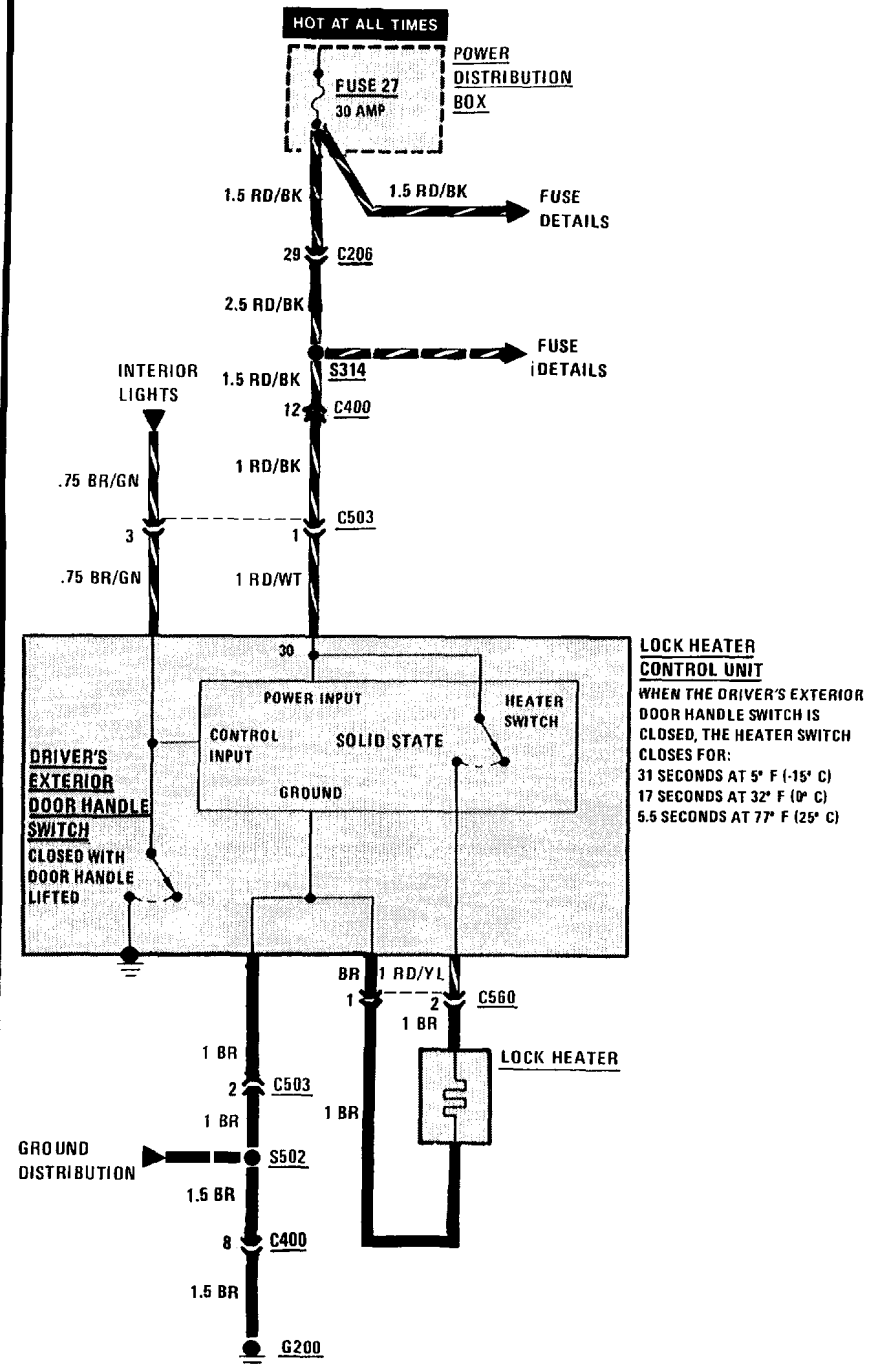

REAR DEFOGGER

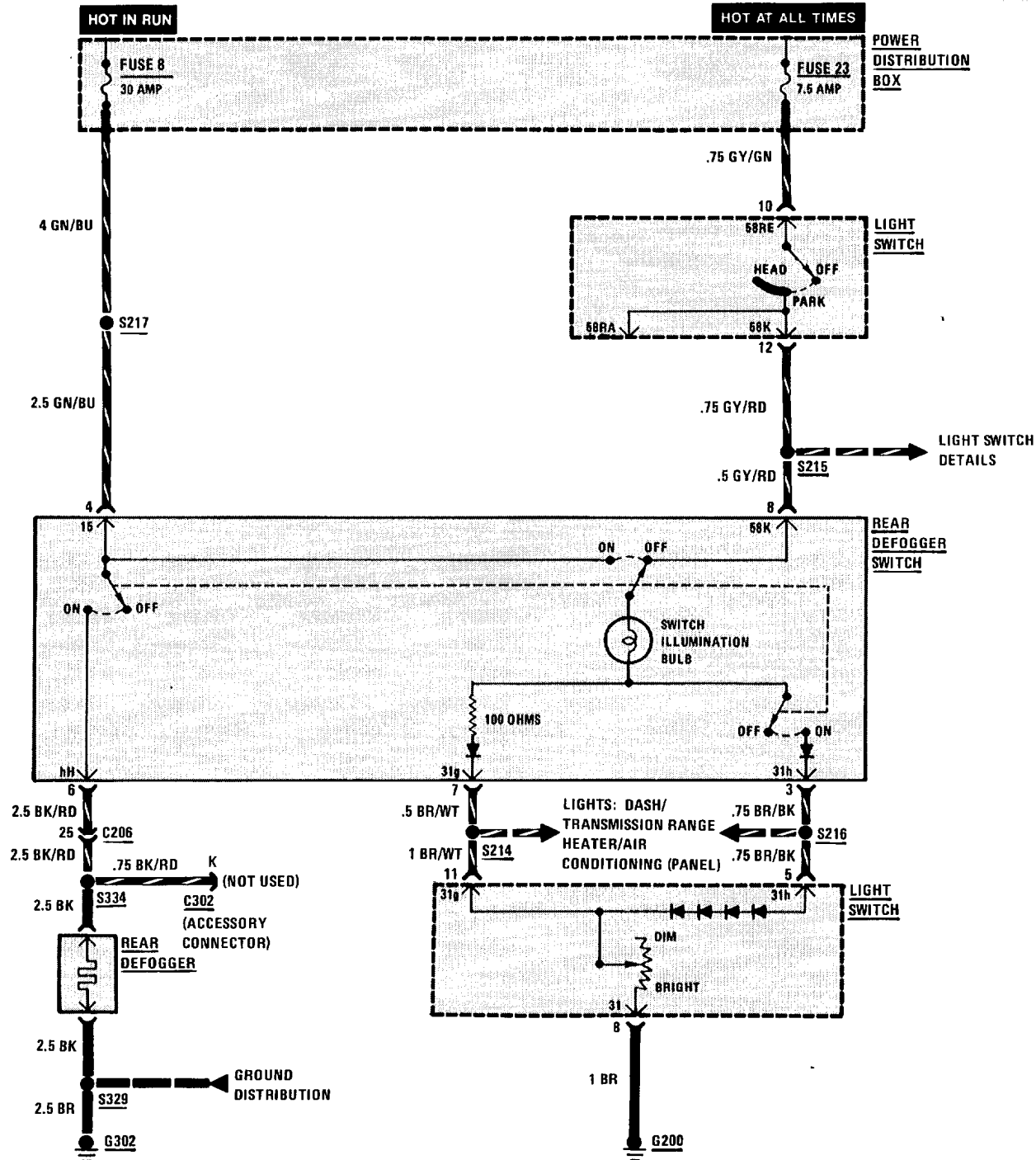

**CIGAR LIGHTER/GLOVE BOX LIGHT/AUTO-CHARGING FLASHLIGHT**

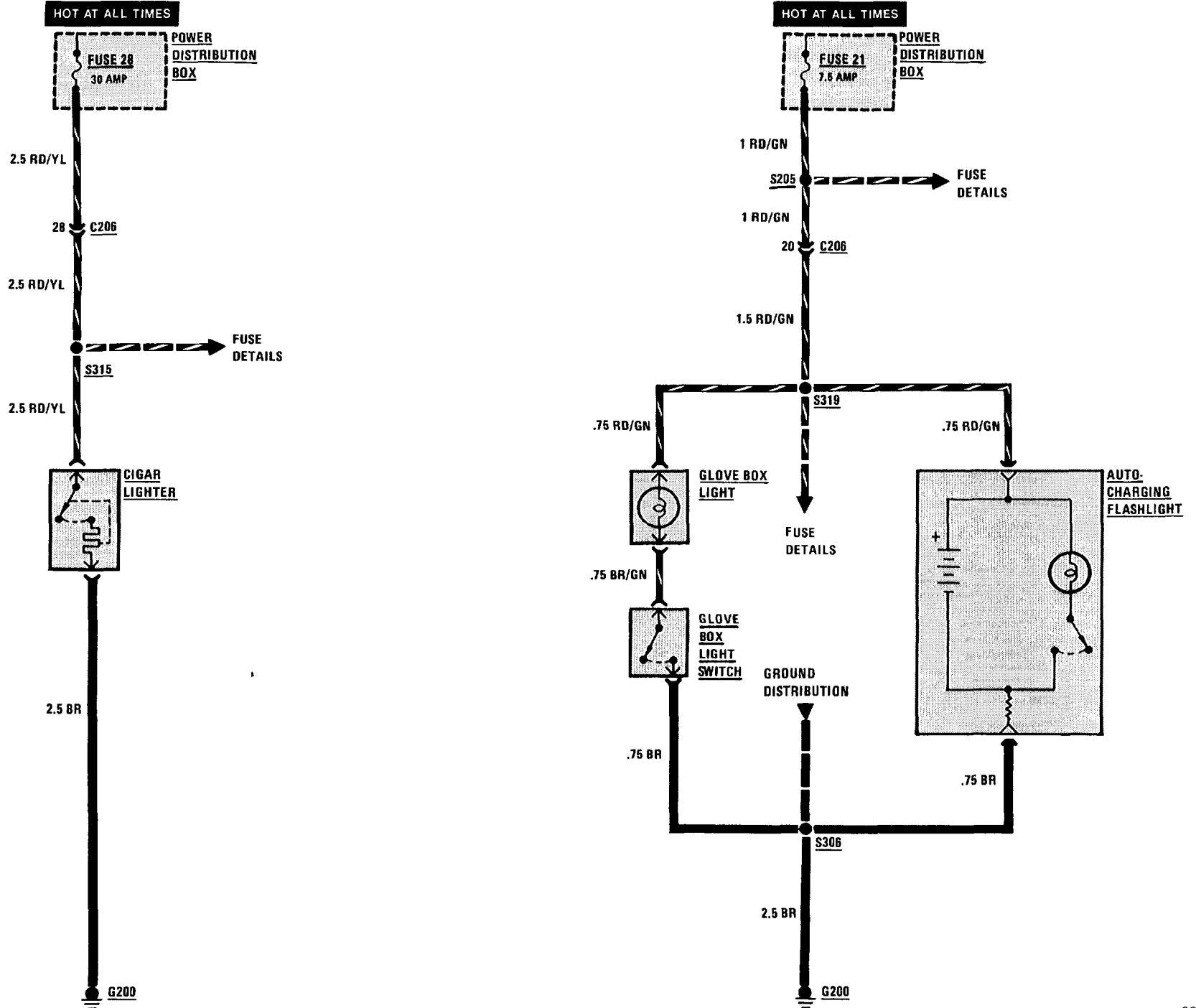

# 6131-0 IGNITION KEY WARNING/SEATBELT WARNING

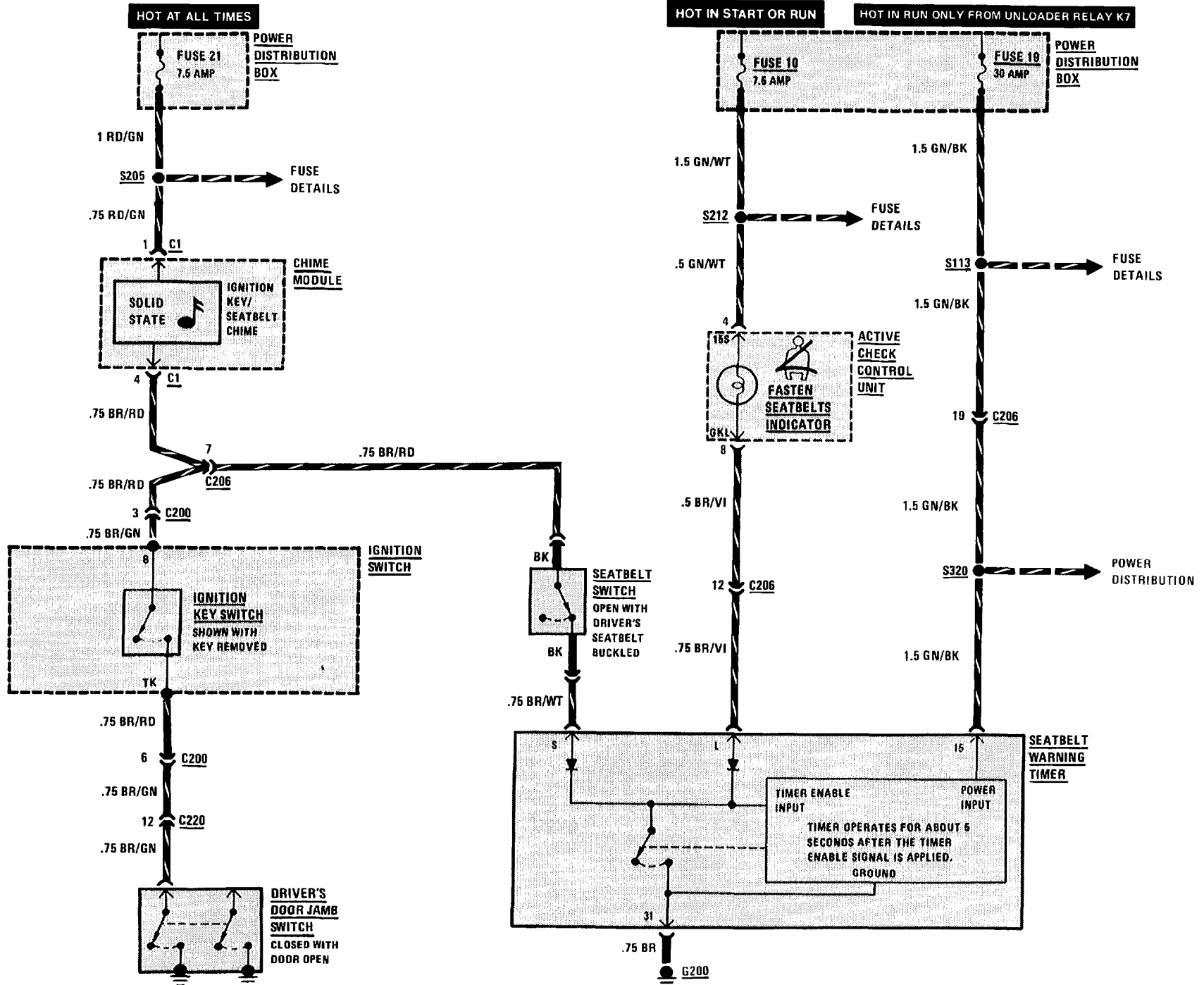



# 6160-0 WIPER/WASHER

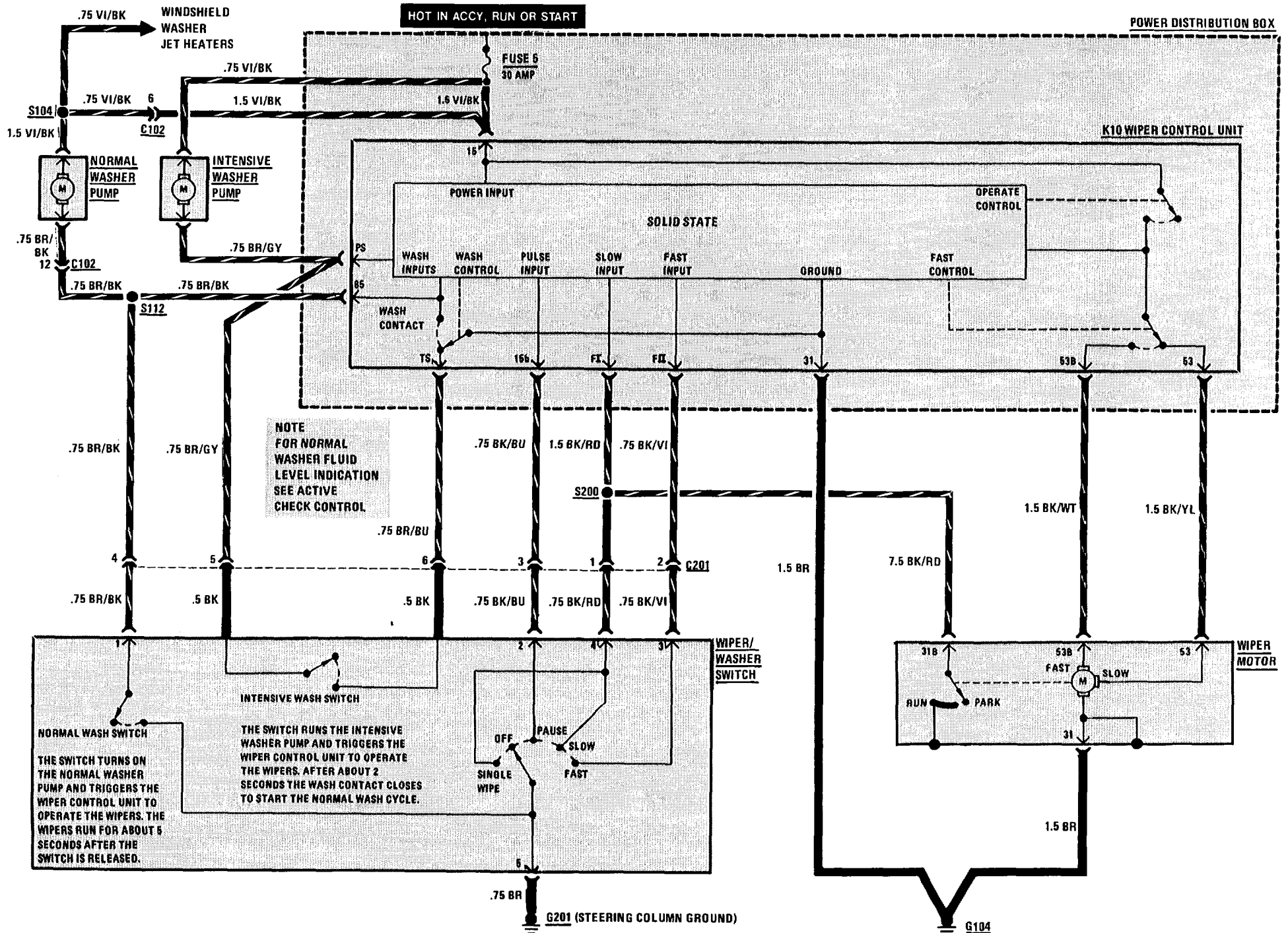

# WINDSHIELD WASHER JET HEATERS 6160-1

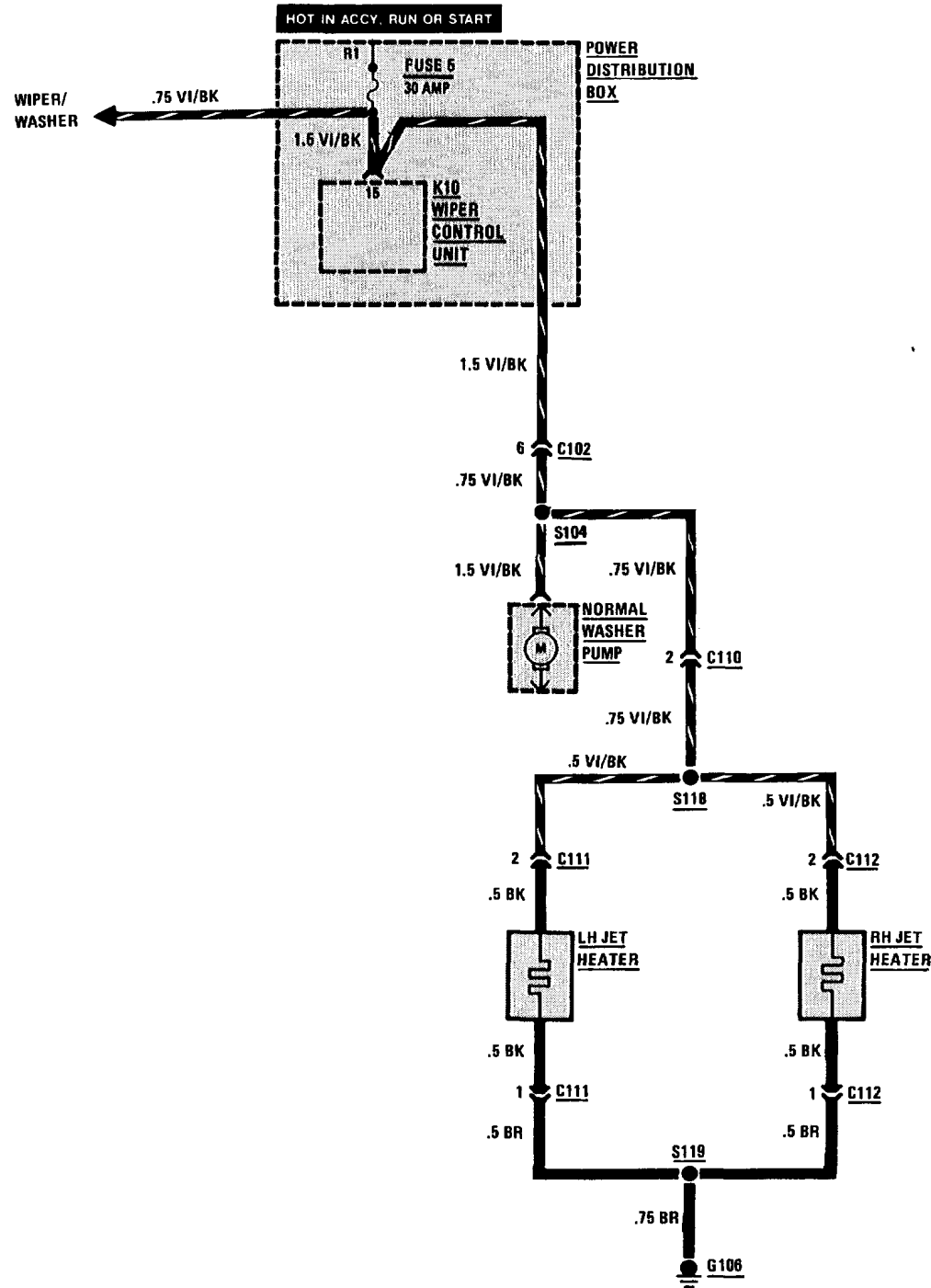

# 6210-0 INSTRUMENT CLUSTER

## SPEEDOMETER/GAUGES/WARNING INDICATORS EARLY PRODUCTION

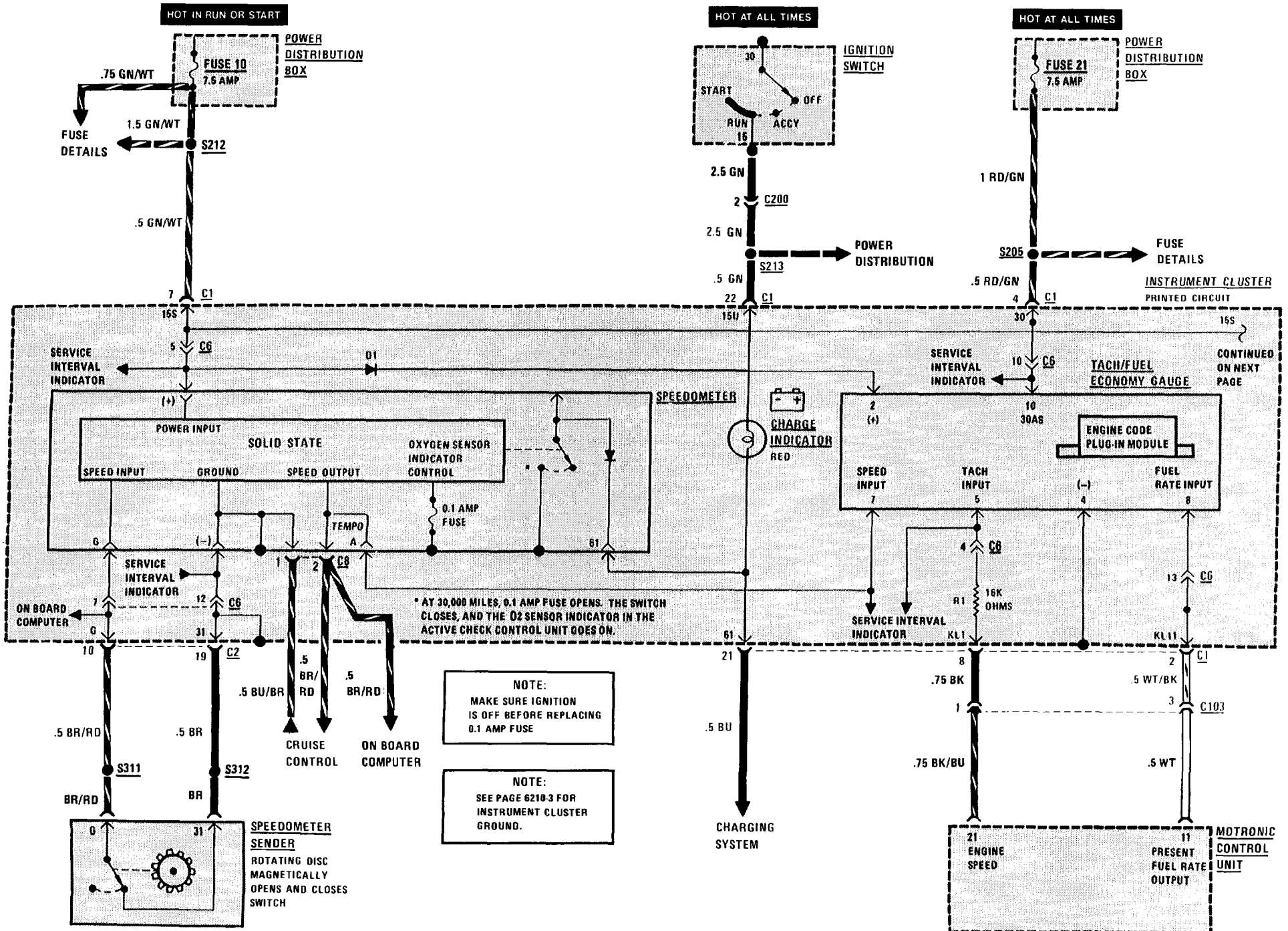

GAUGES/WARNING INDICATORS EARLY PRODUCTION

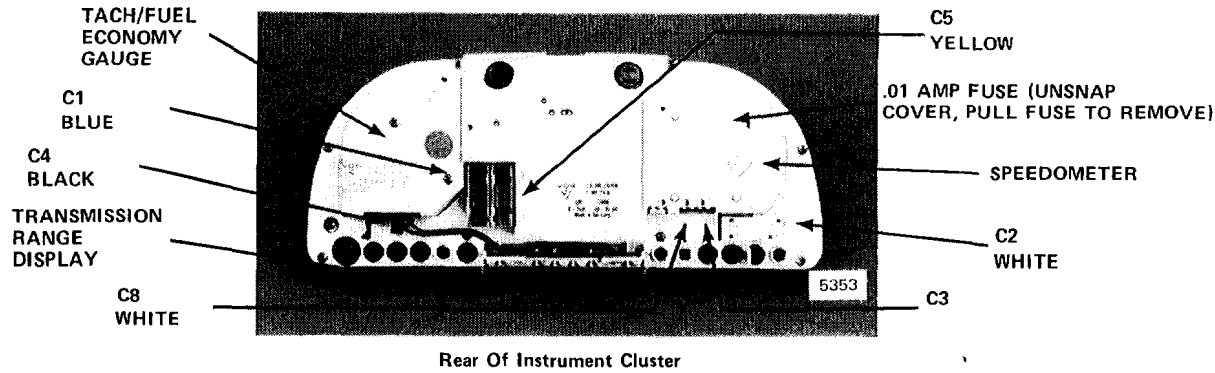

Rear Of Instrument Cluster

INSTRUMENT CLUSTER PRINTED CIRCUIT

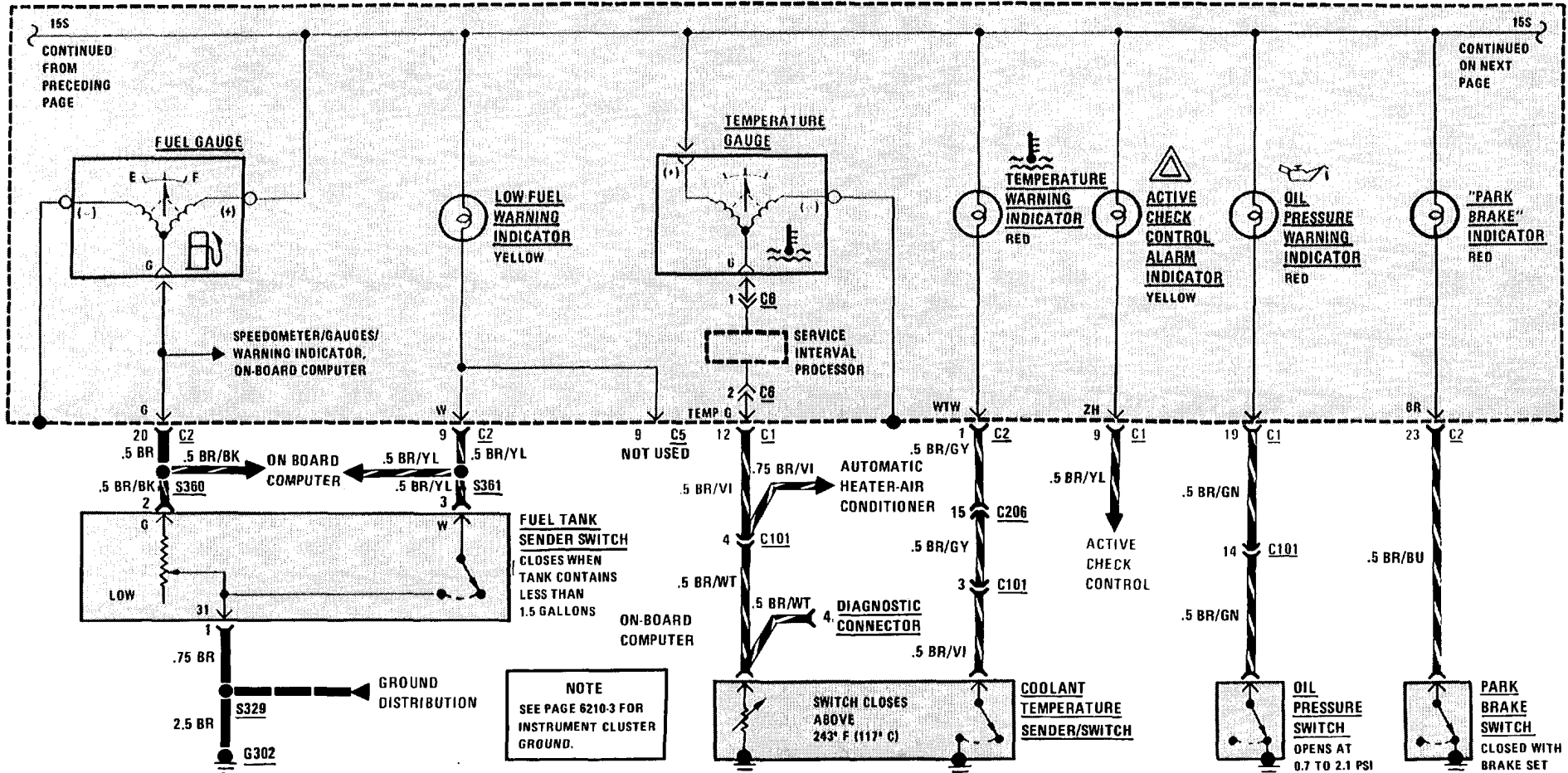

WARNING INDICATORS EARLY PRODUCTION

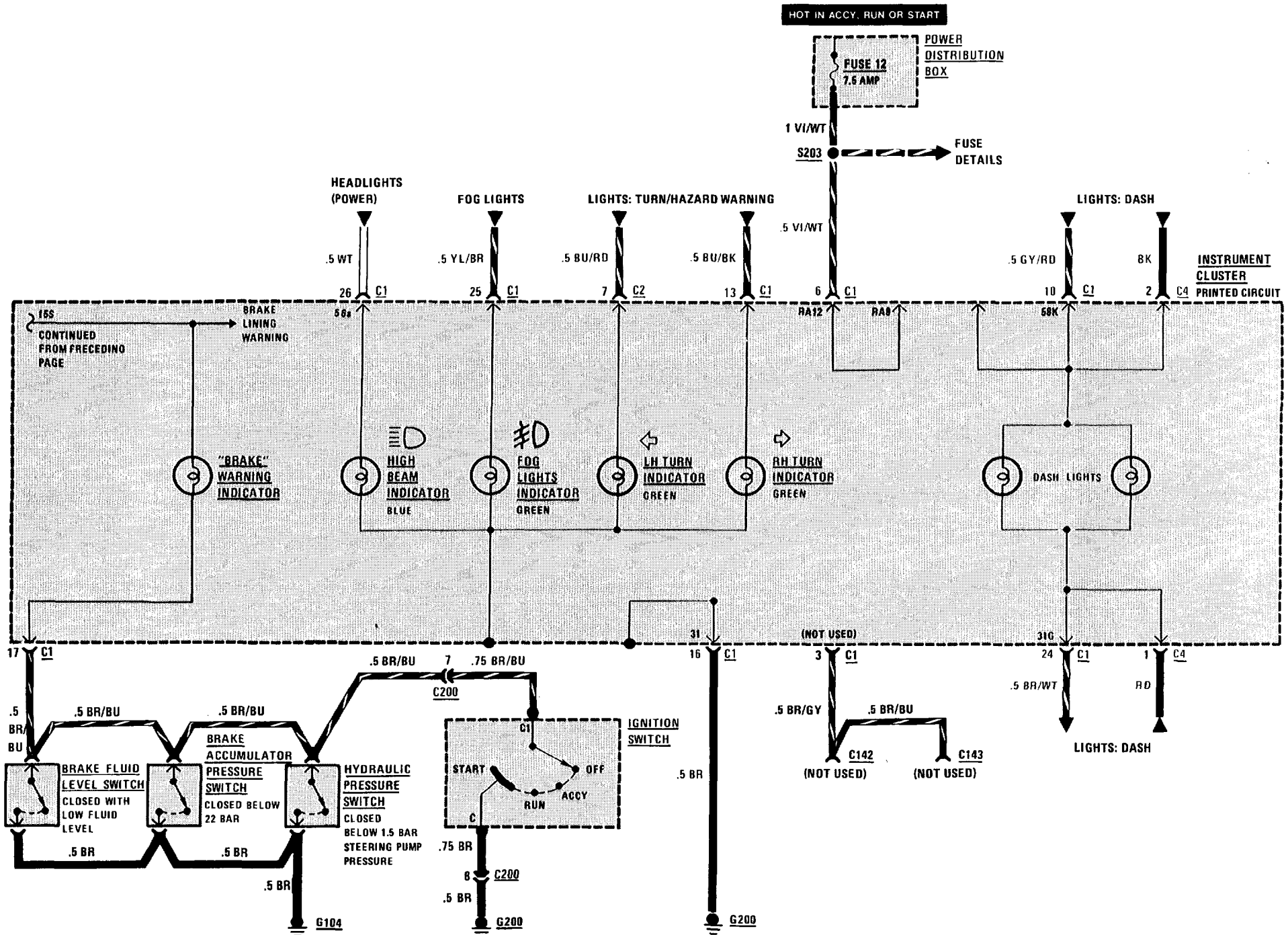

## SERVICE INTERVAL INDICATOR EARLY PRODUCTION

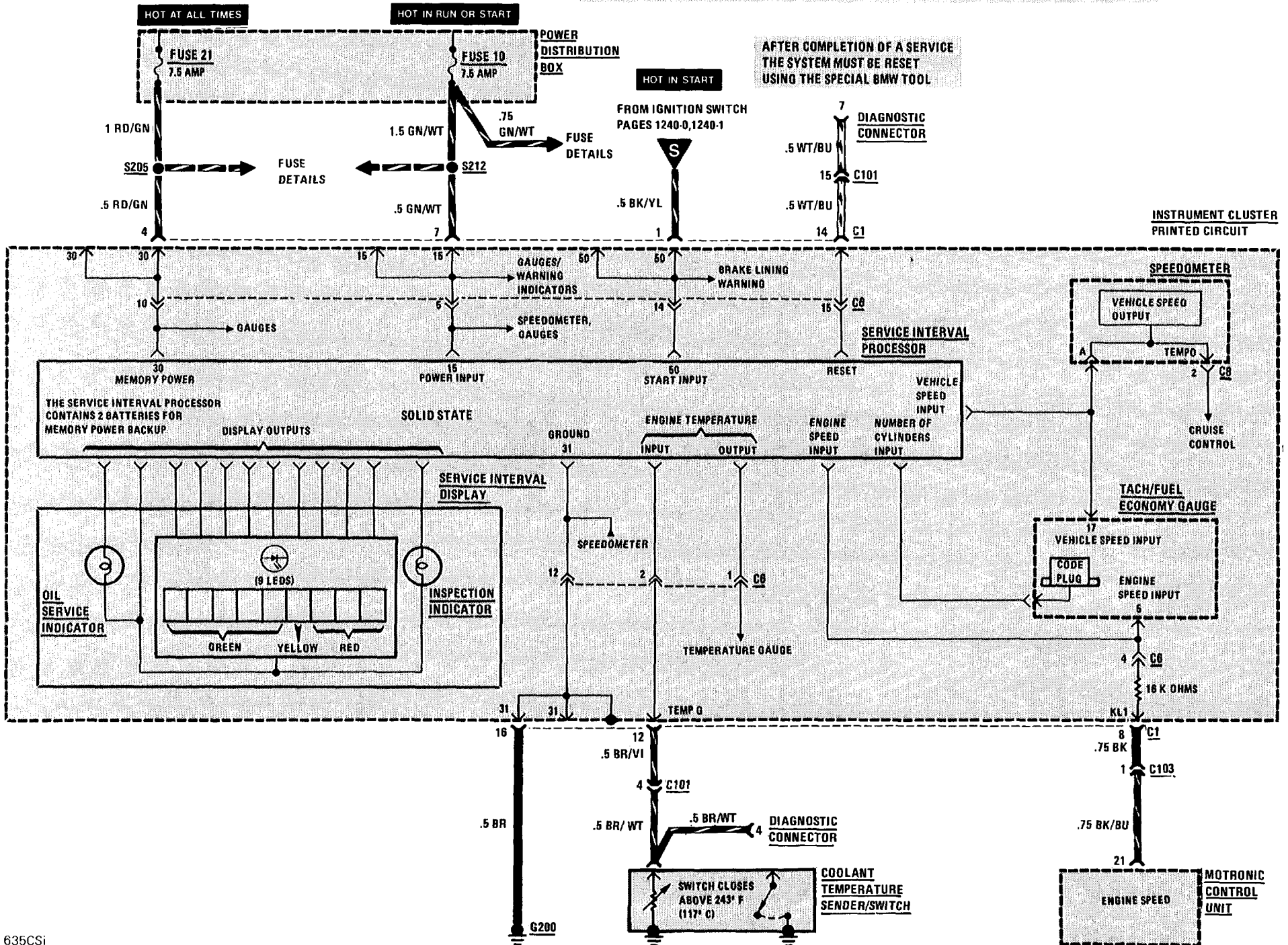

# 6210-4 INSTRUMENT CLUSTER

## SPEEDOMETER/GAUGES/WARNING INDICATORS LATE PRODUCTION

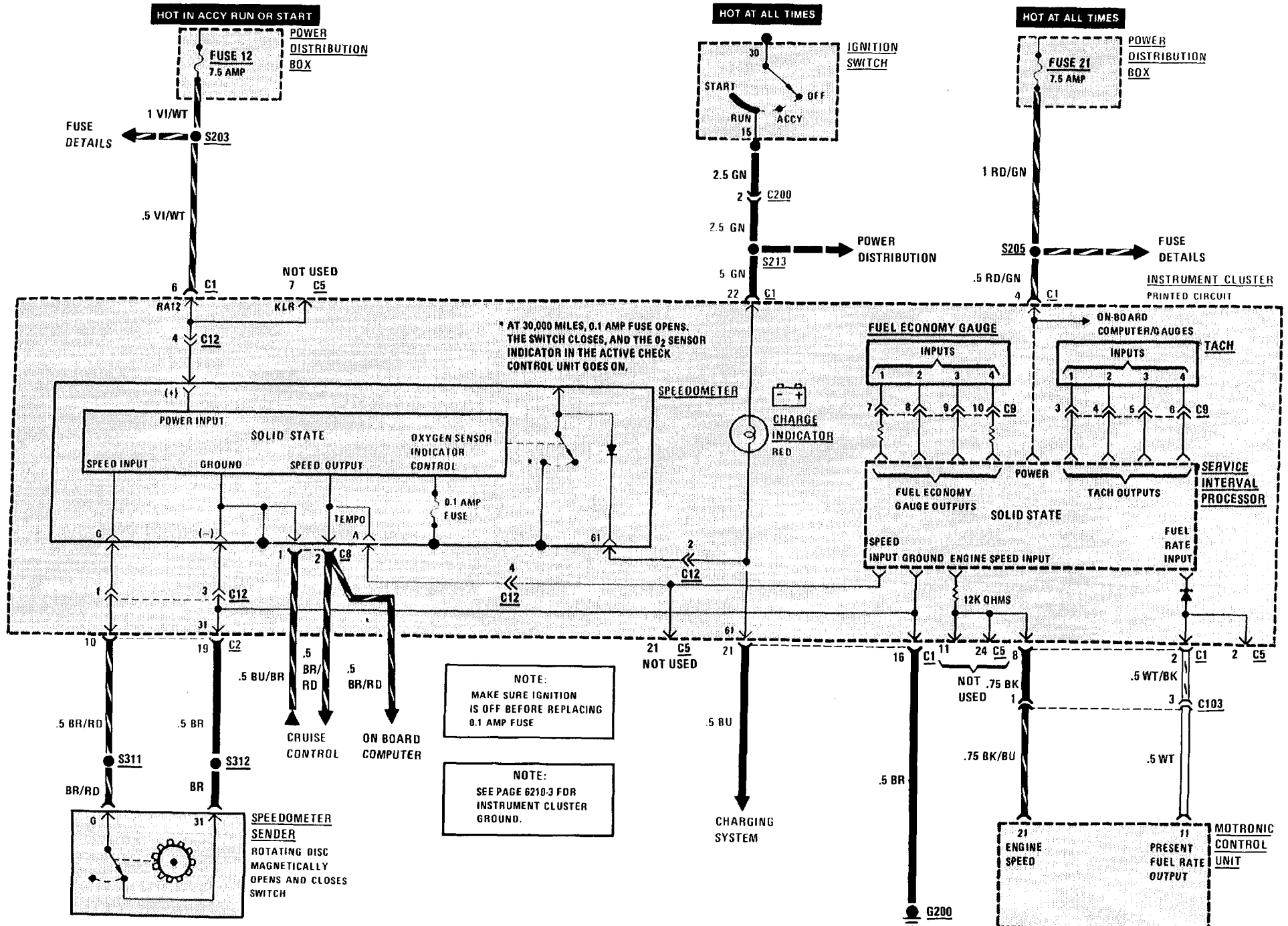

GAUGES/WARNING INDICATORS LATE PRODUCTION

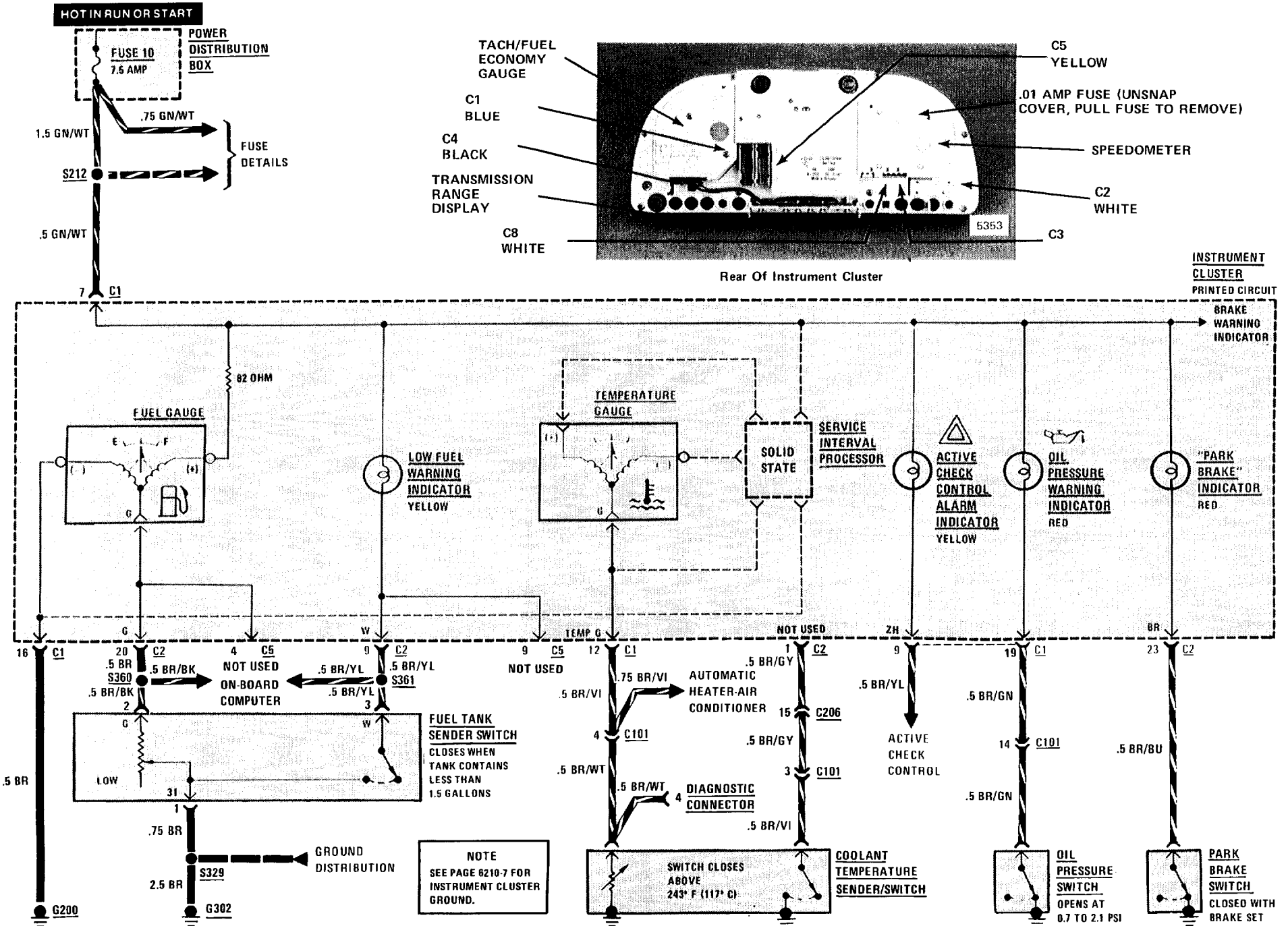



# 6210-6 INSTRUMENT CLUSTER

## WARNING INDICATORS LATE PRODUCTION

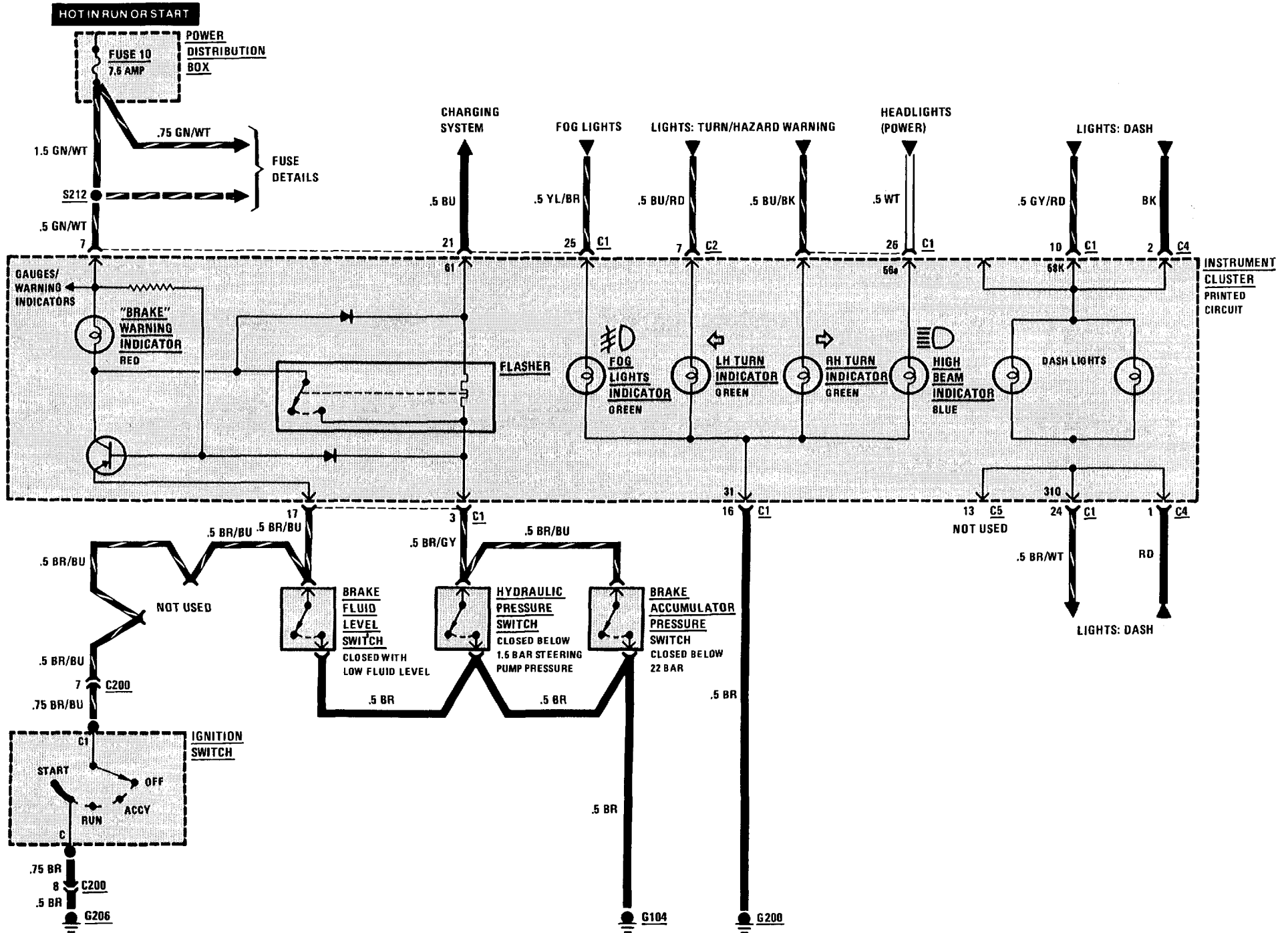

SERVICE INTERVAL INDICATOR LATE PRODUCTION

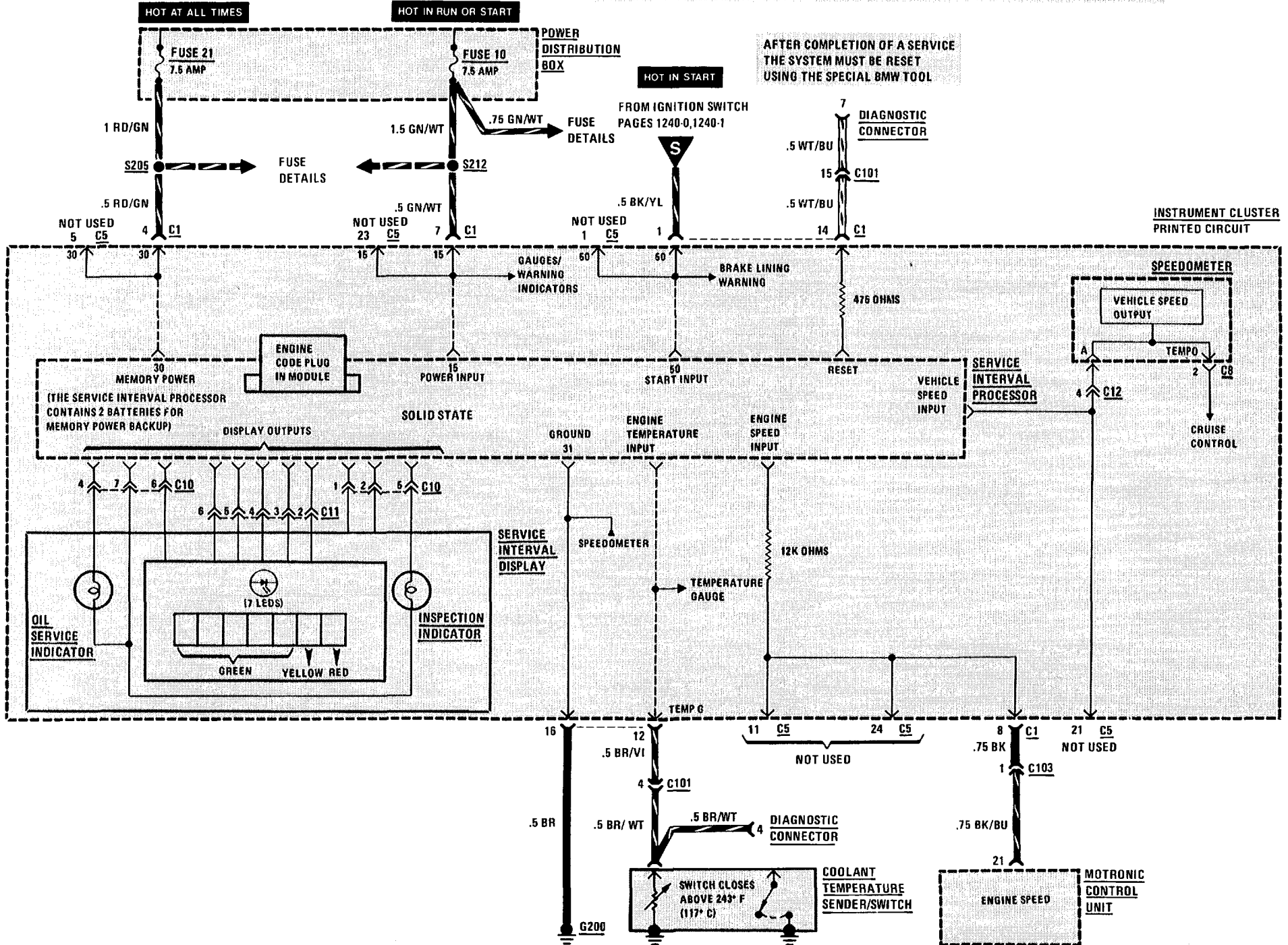

## ACTIVE CHECK CONTROL

1. When the Ignition Switch is initially placed in "Run," the Active Check Control Arm Indicator flashes, and the Active Check Control Unit Brake Light LED and panel light illuminate for test purposes. Depressing the brake pedal clears the display.
2. When the Ignition Switch is placed in "Run," fault monitoring begins. To monitor the low beams, rear lights, or license lights, those circuits must be on. The brake lights are monitored only while the brake pedal is depressed.
3. When a fault occurs, the alarm indicator flashes, the appropriate LED fault indicator lights, and the panel light goes on for five seconds. Depressing the test button will clear the alarm indicator, but the LED fault indicator remains on.

4. To test the unit, depress the test button. The LED fault indicators and the panel lights should go on.

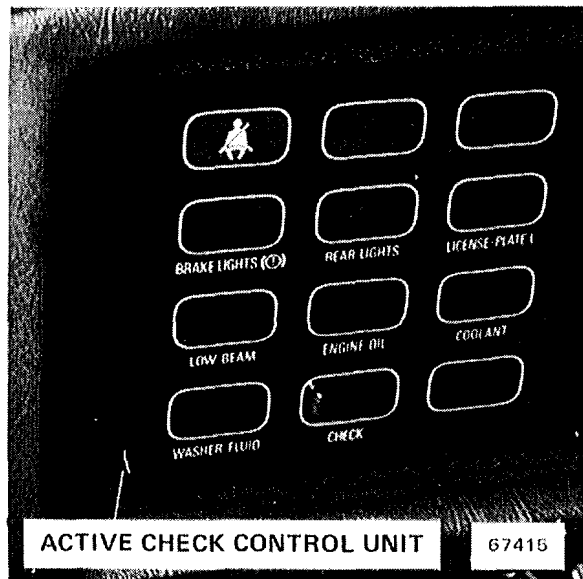
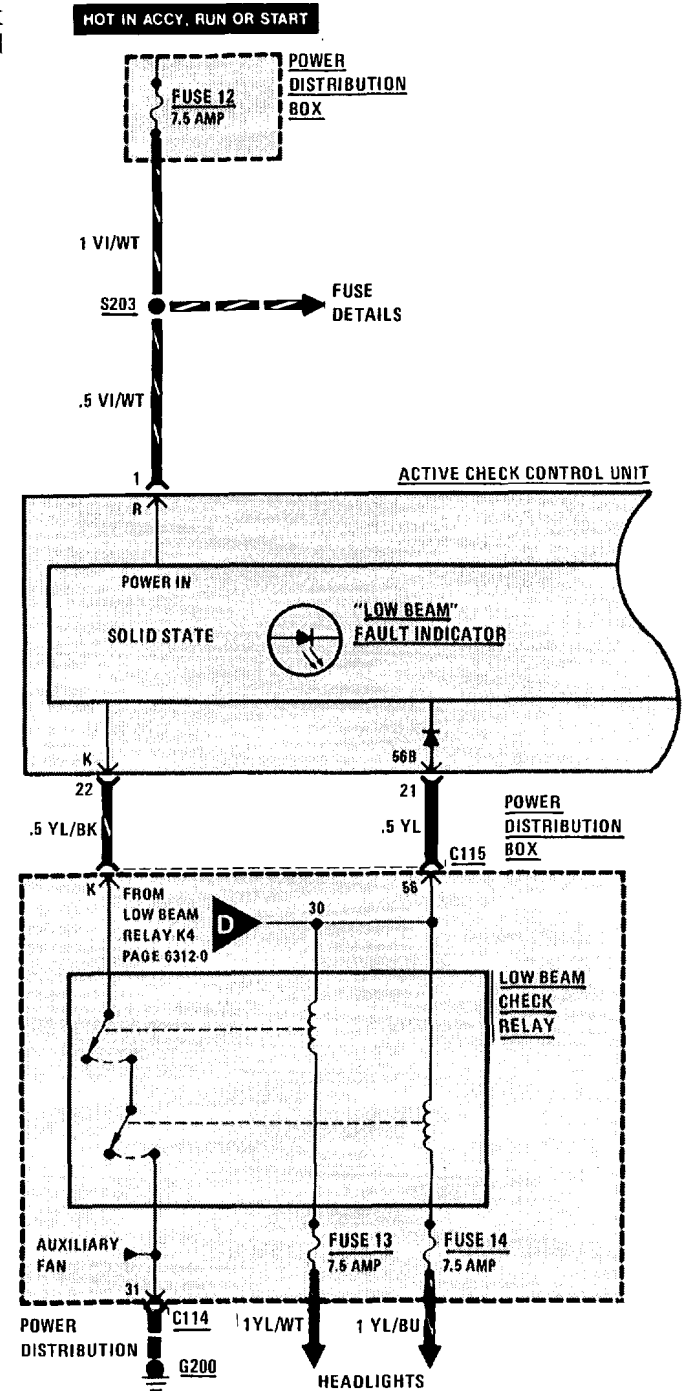
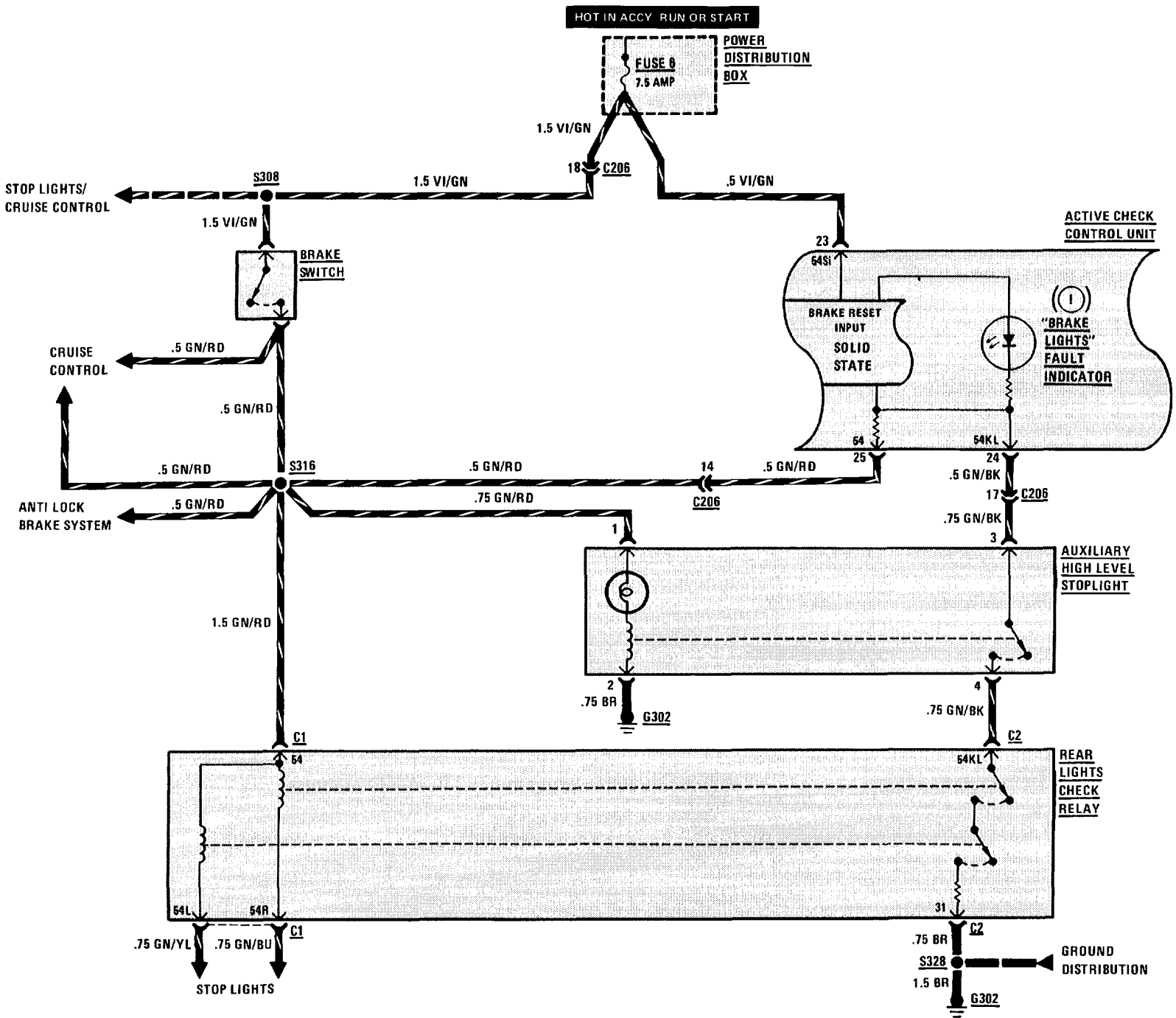
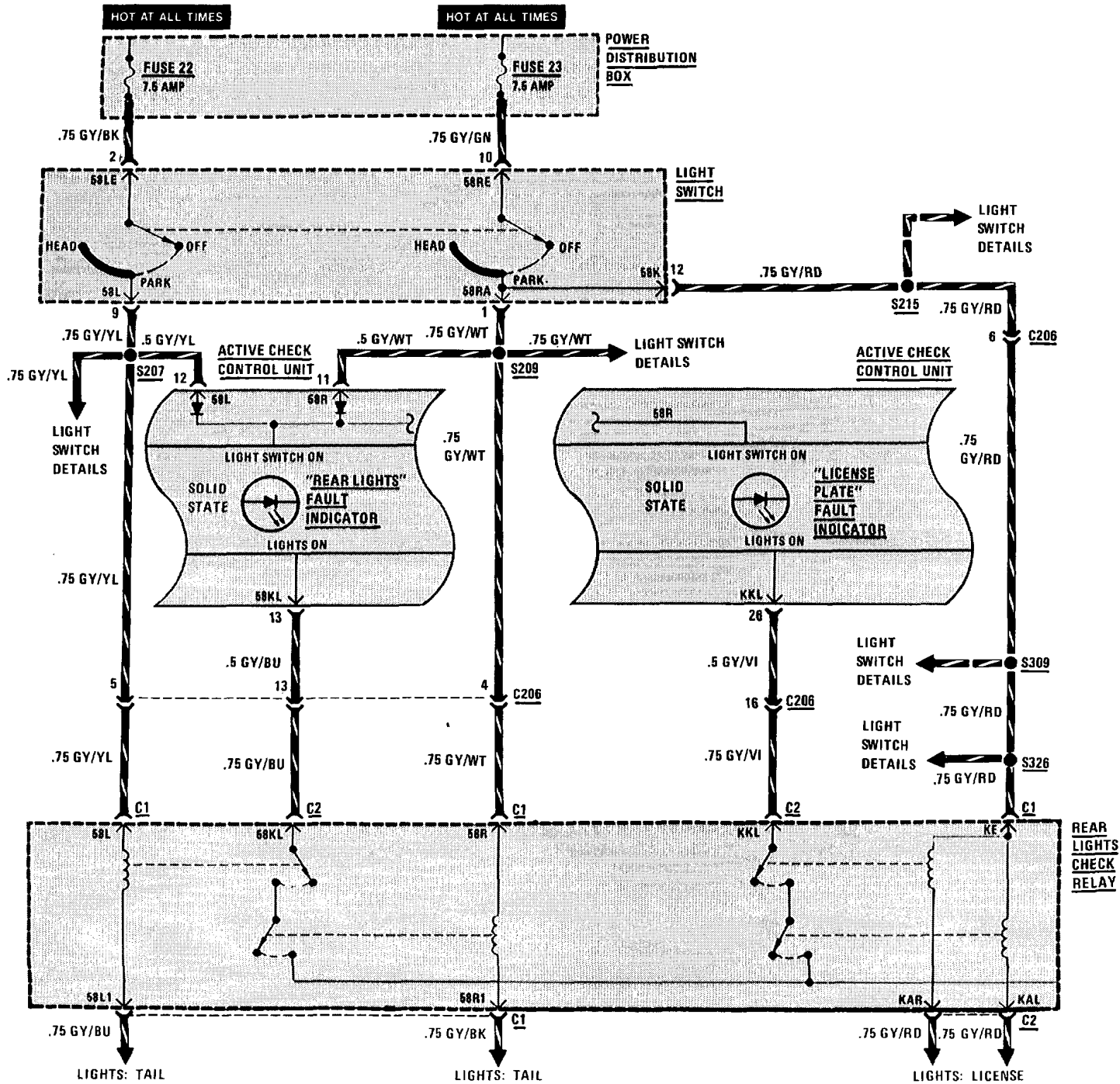

Figure 1 - Active Check Control Unit (Dash, Left Of Steering Column)





# 6216-2 ACTIVE CHECK CONTROL



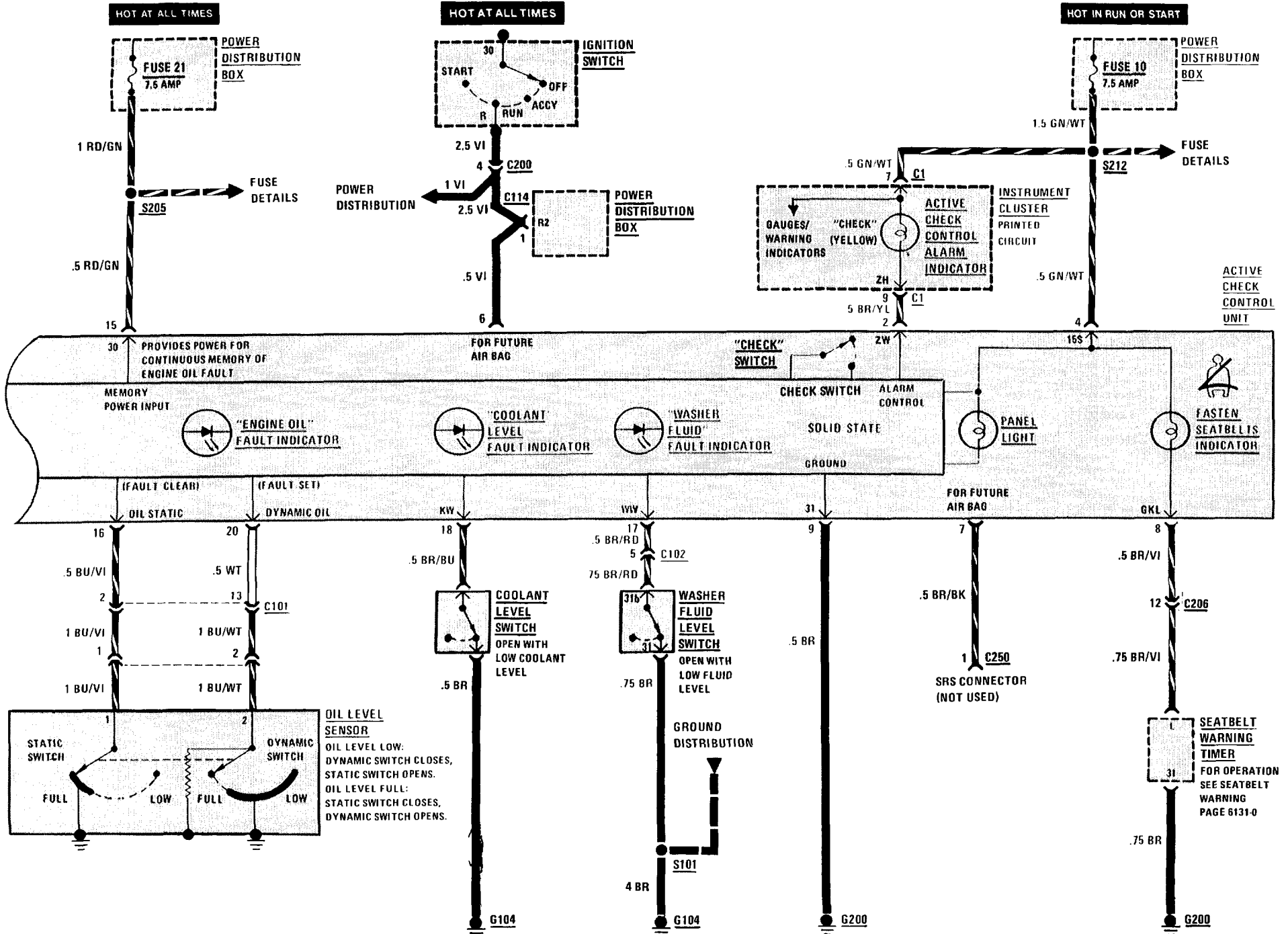



LIGHTS: DASH/TRANSMISSION RANGE

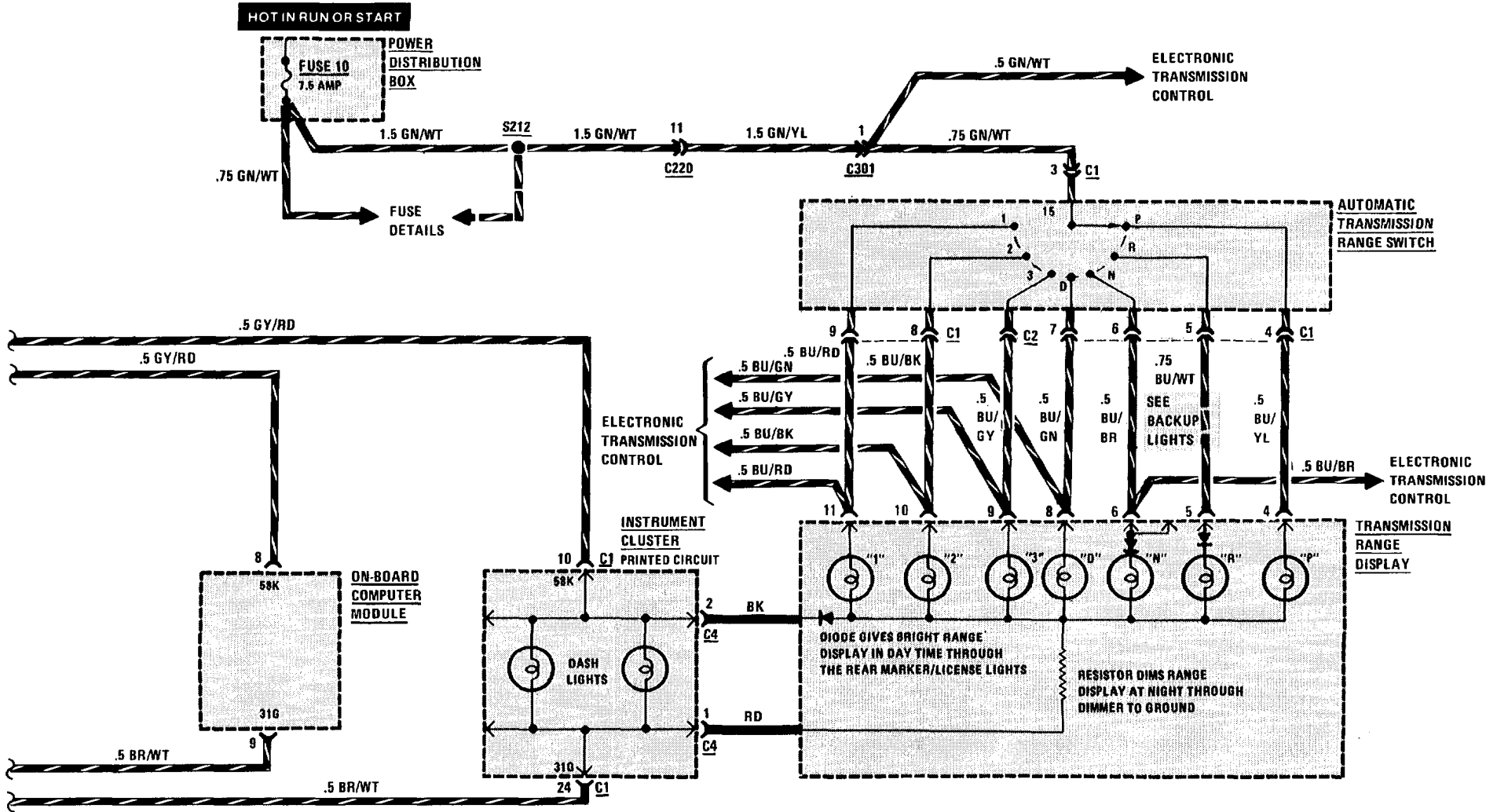



# 6300-2 LIGHT SWITCH DETAILS

HOT AT ALL TIMES

NOTE: LIGHT SWITCH DETAILS FOR HEADLIGHTS AND FOG LIGHTS SEE PAGE 6312-0

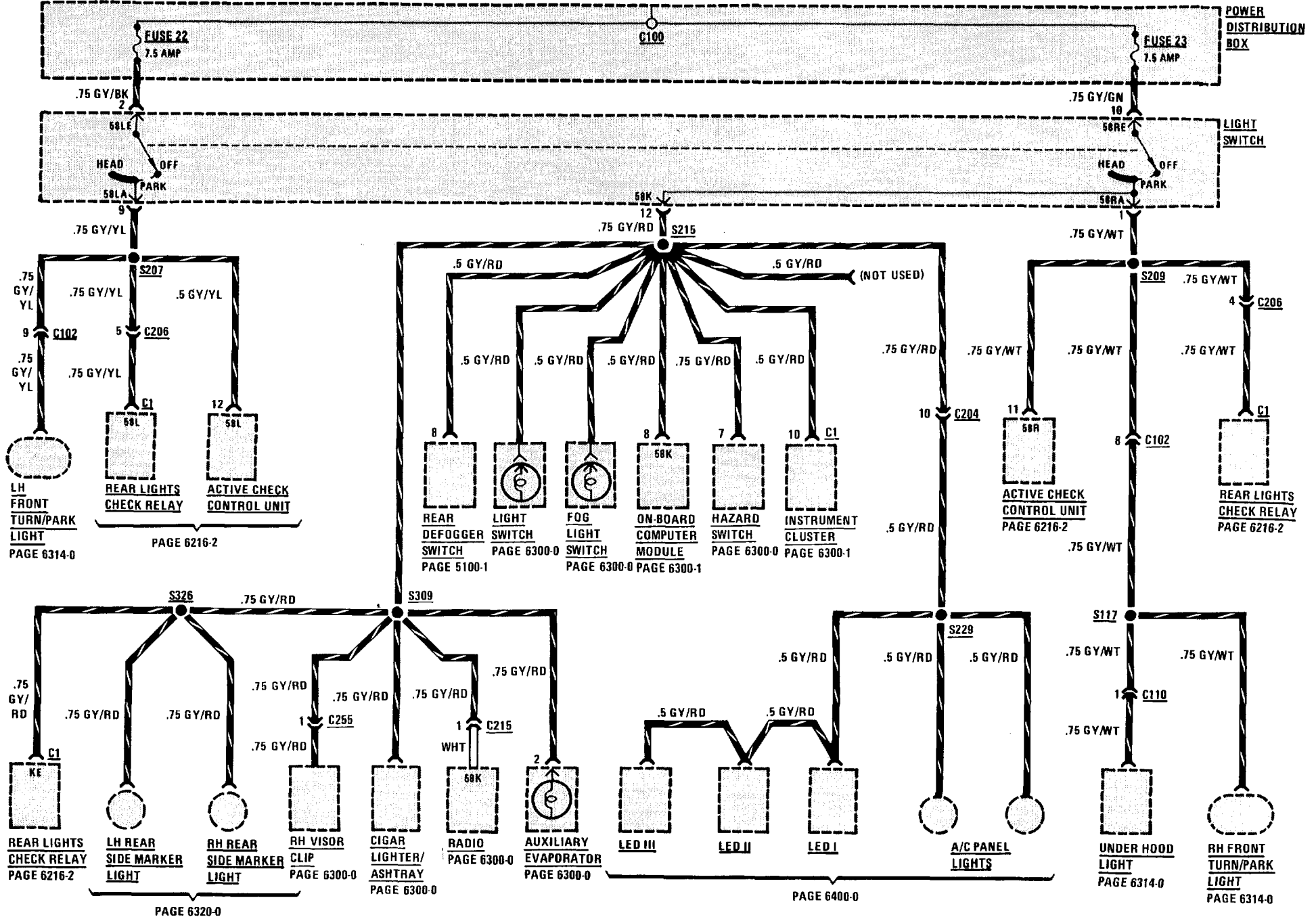

# 6312-0 HEADLIGHTS/FOG LIGHTS

## HEADLIGHTS (CONTROL) AND FOG LIGHTS

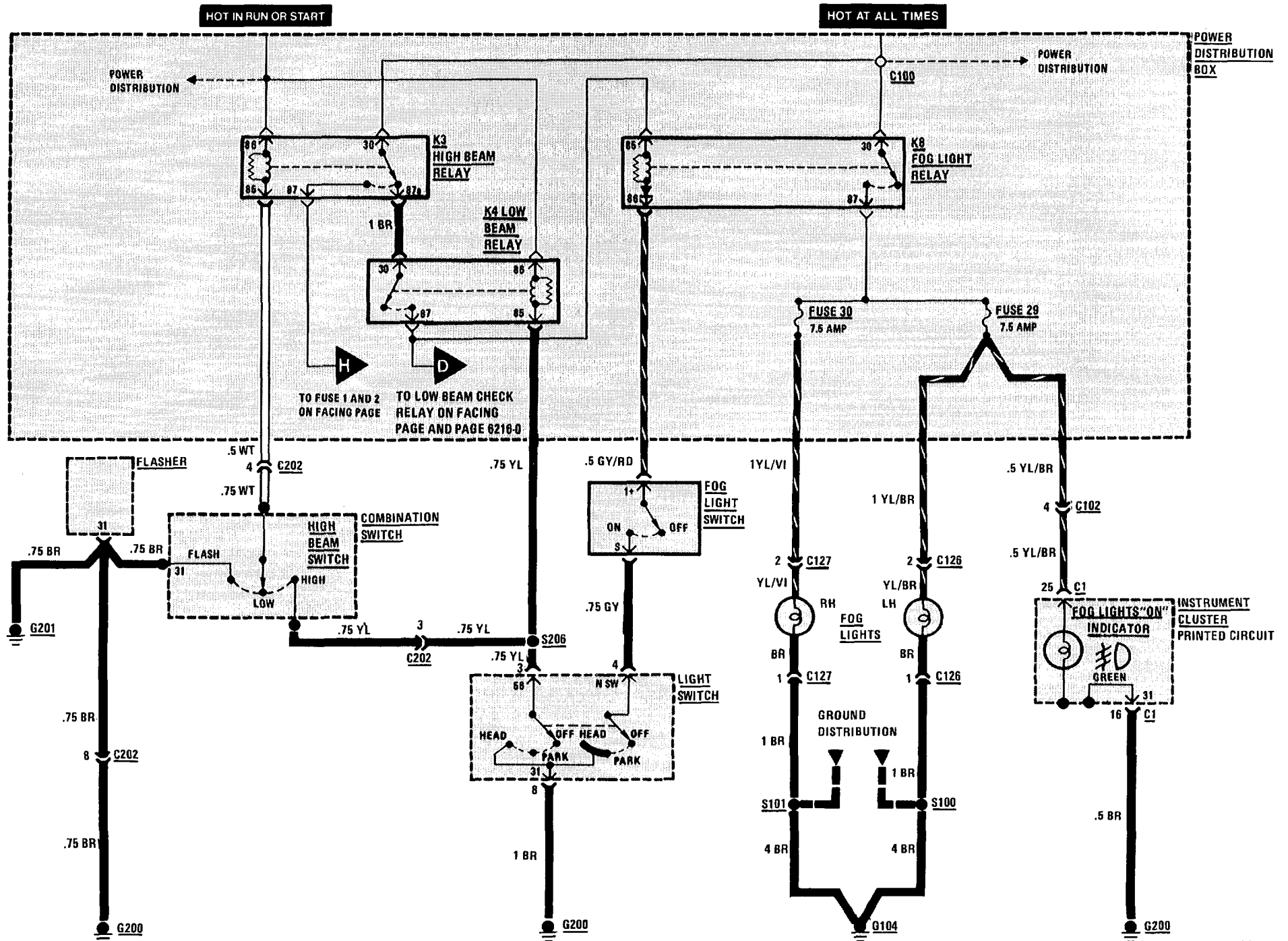

## HEADLIGHTS (POWER)

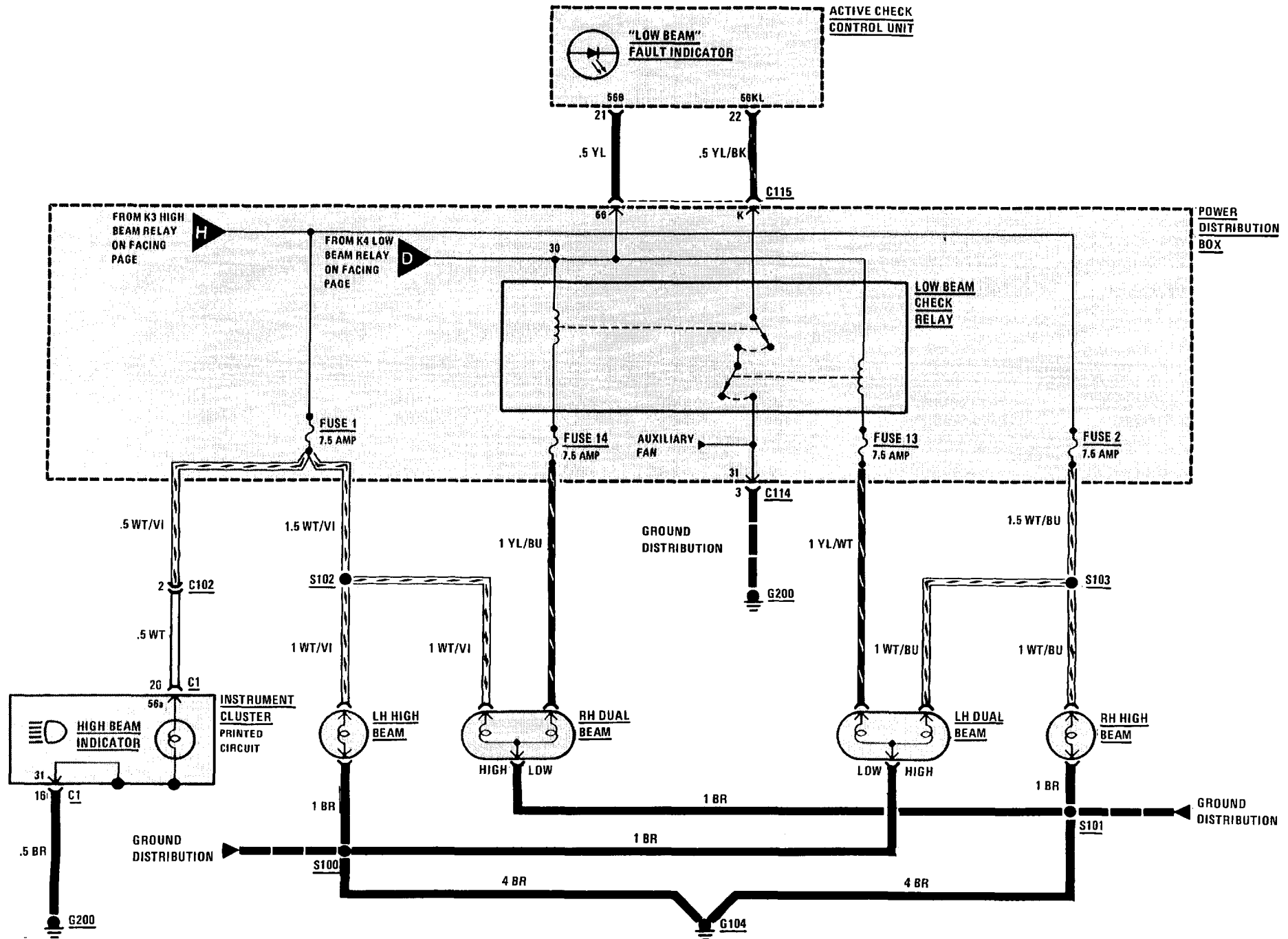

# 6313-0 TURN/HAZARD LIGHTS

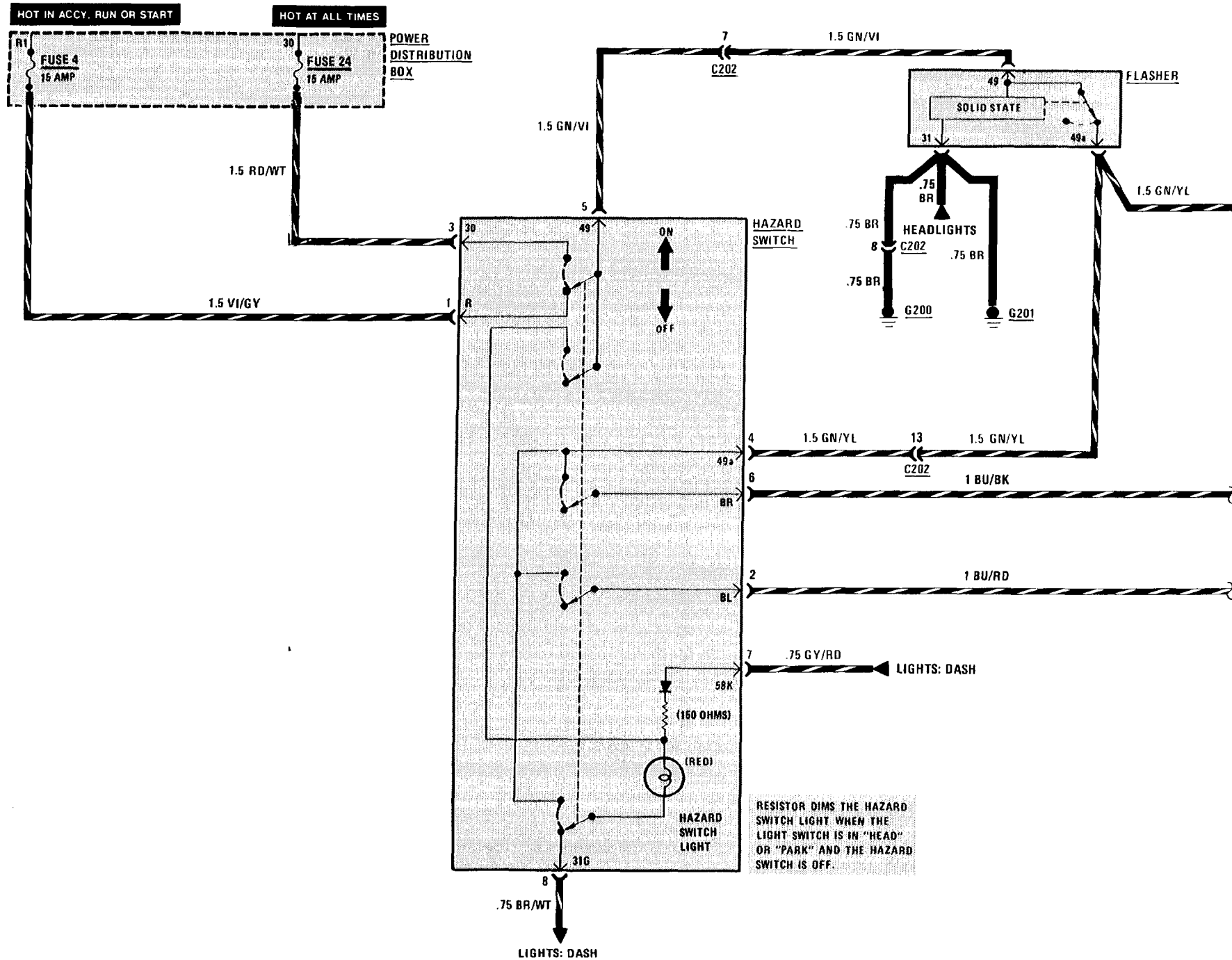

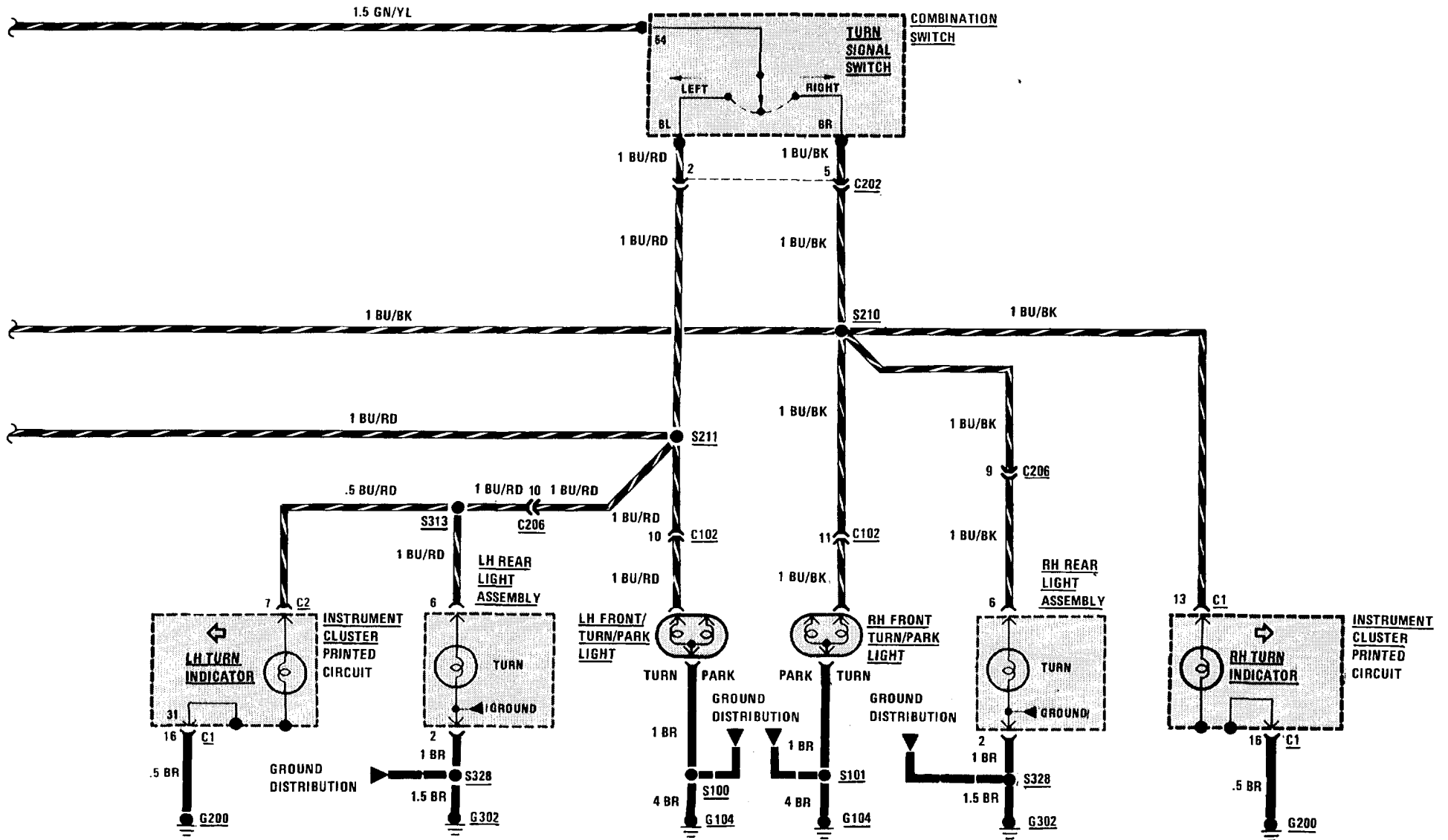

# 6314-0 PARK/TAIL/UNDERHOOD LIGHTS

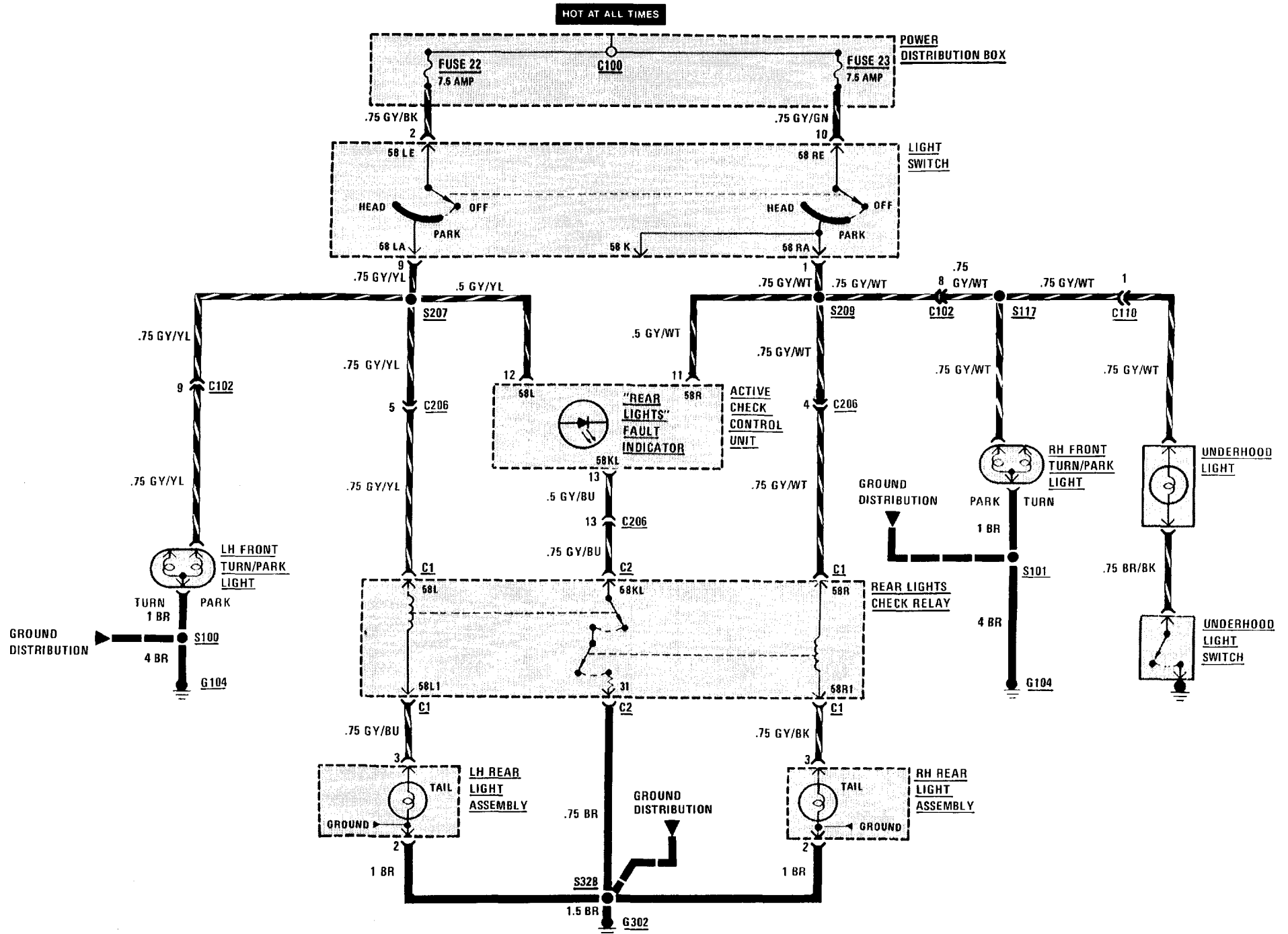

# 6320-0 REAR MARKER/LICENSE/TRUNK LIGHTS

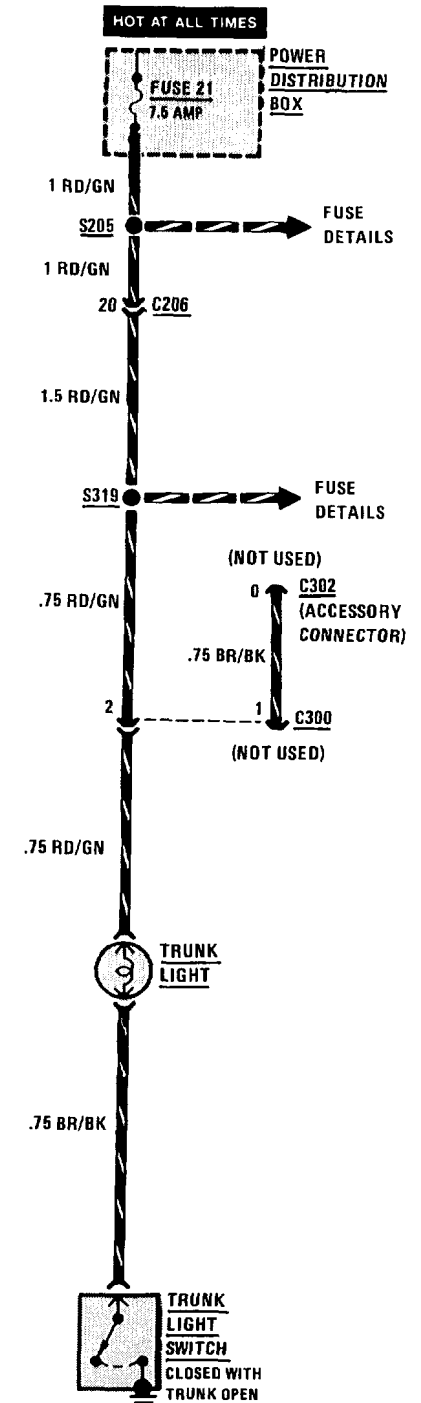
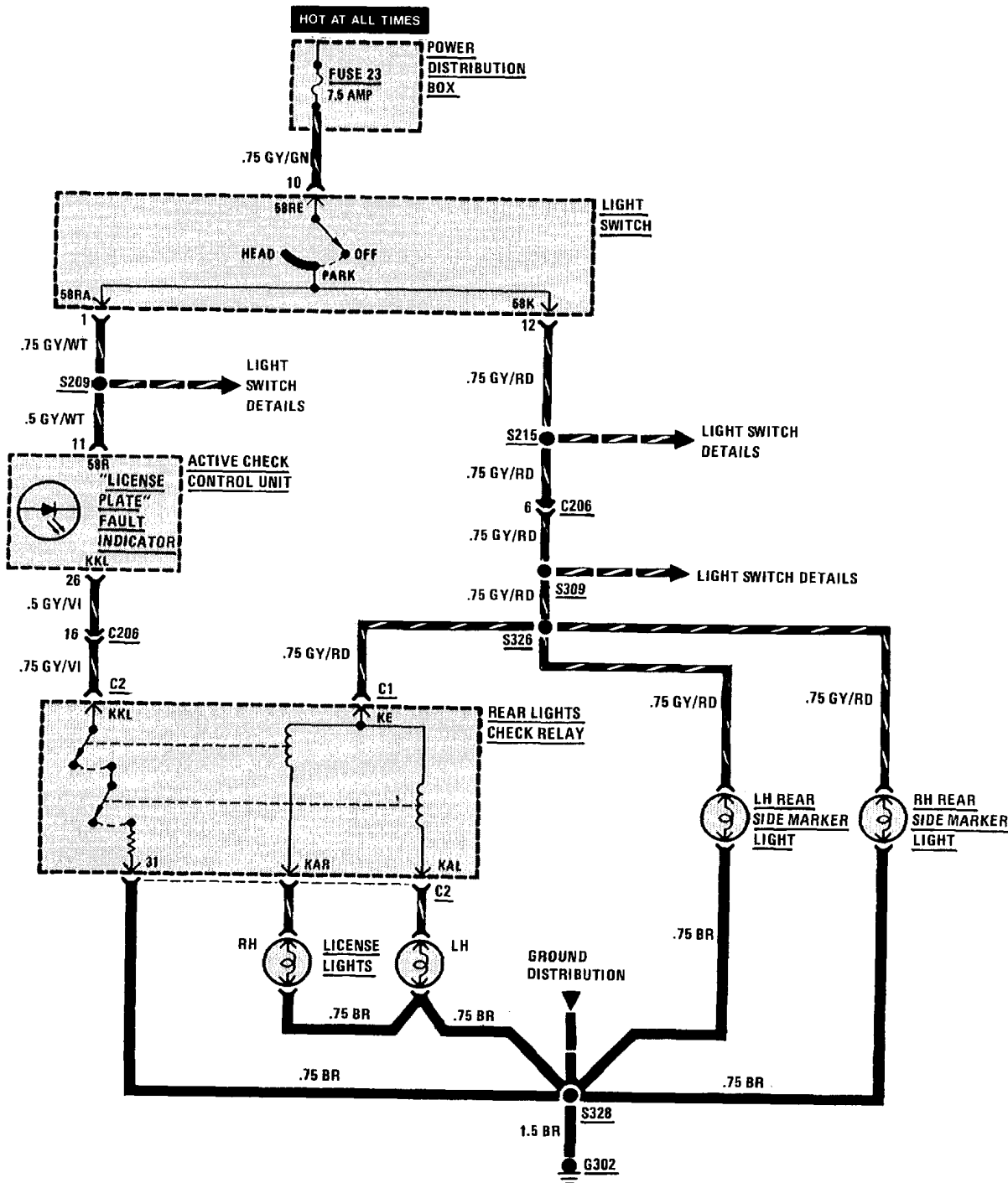

# 6322-0 BACKUP LIGHTS

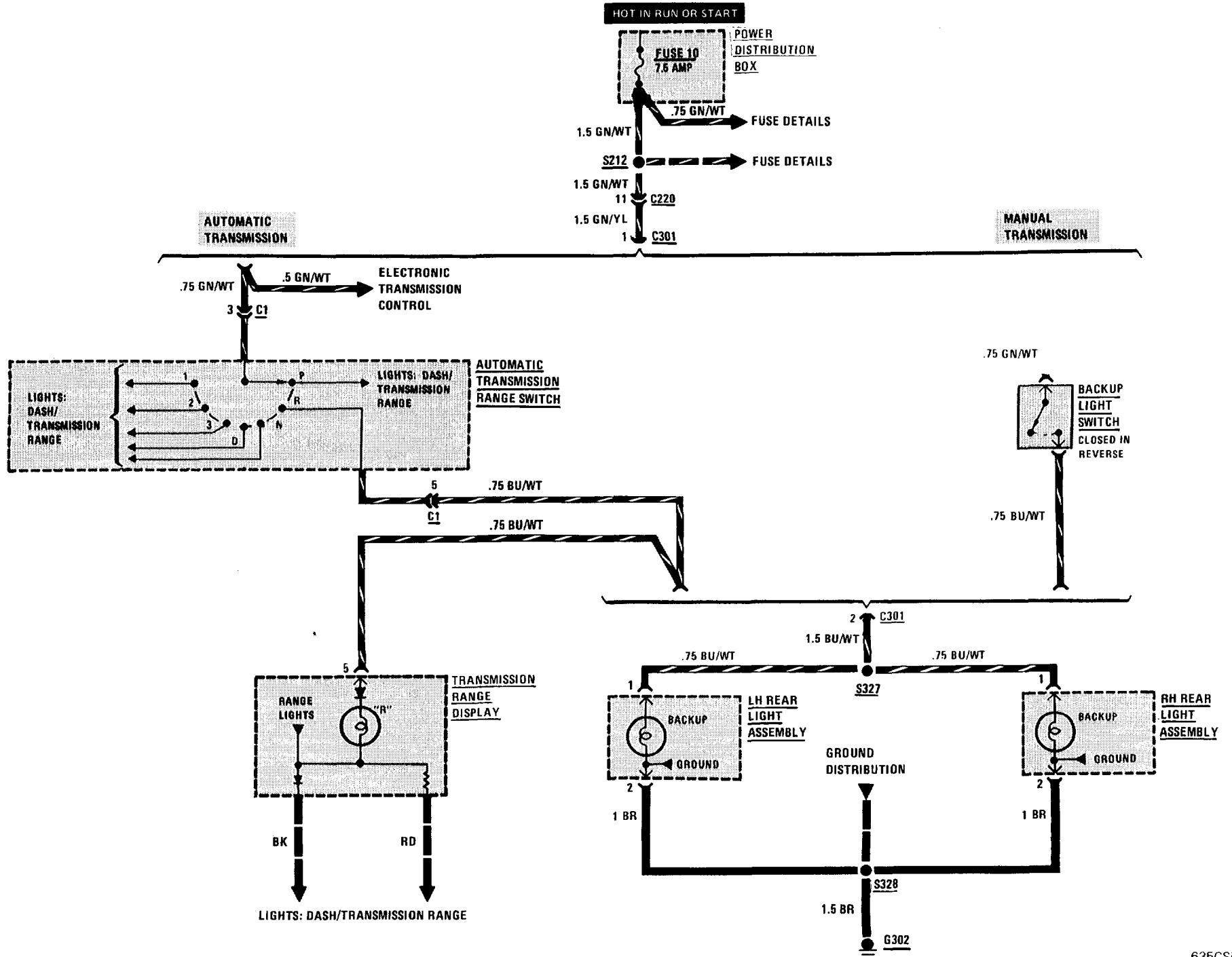



# 6325-0 STOP LIGHTS

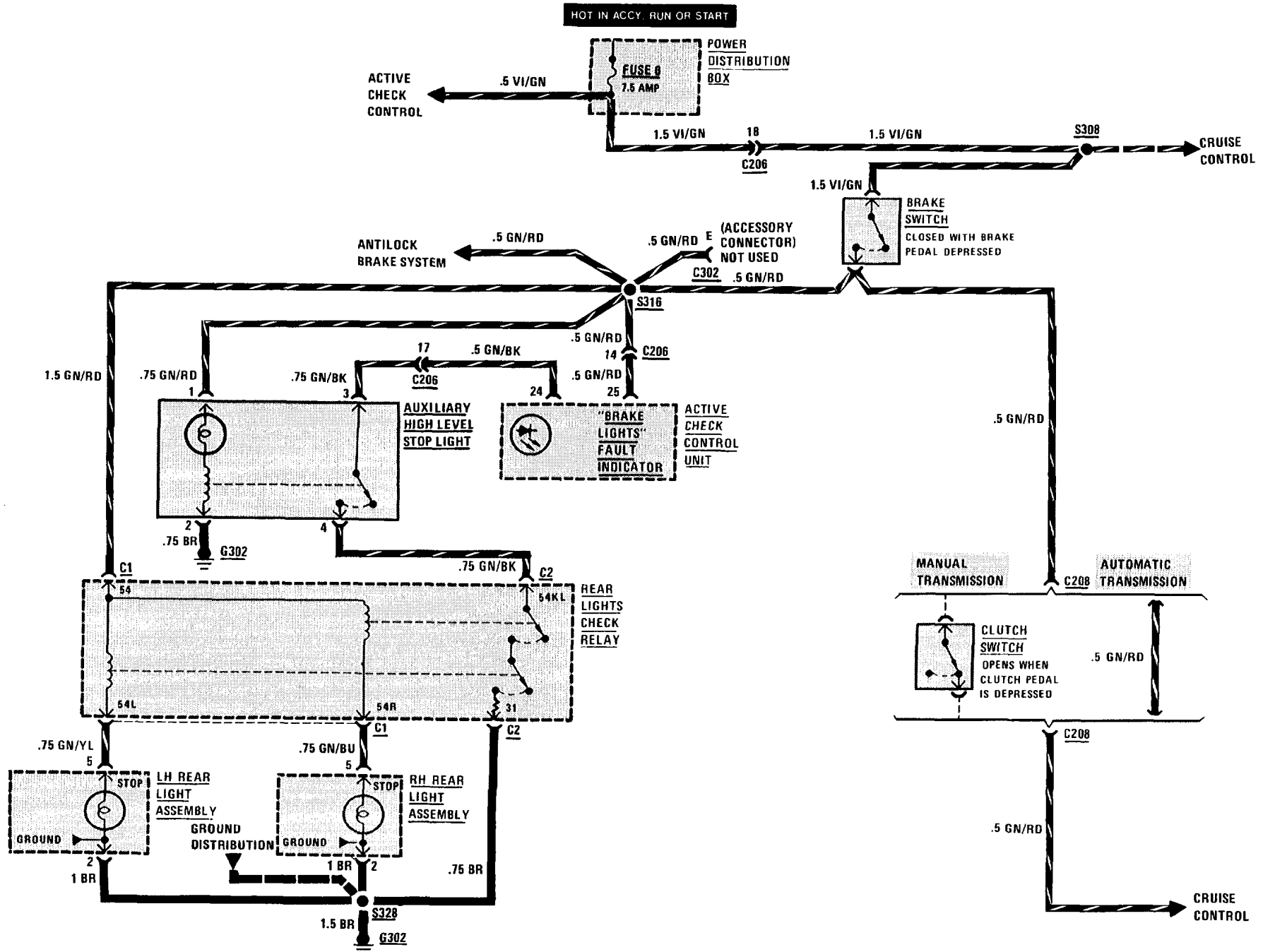

# 6330-0 INTERIOR LIGHTS

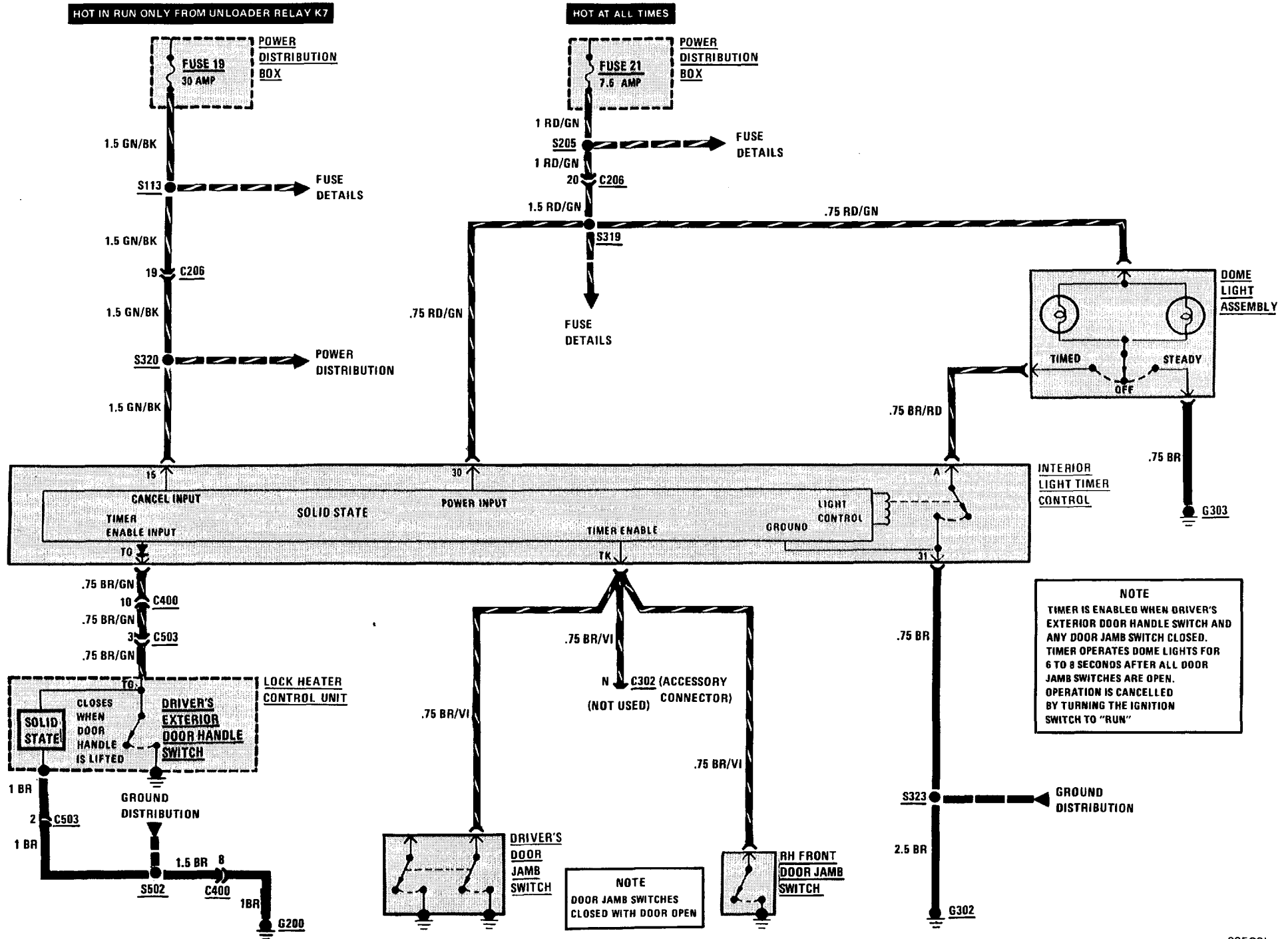

## HEATING AND A/C PANEL LIGHTS

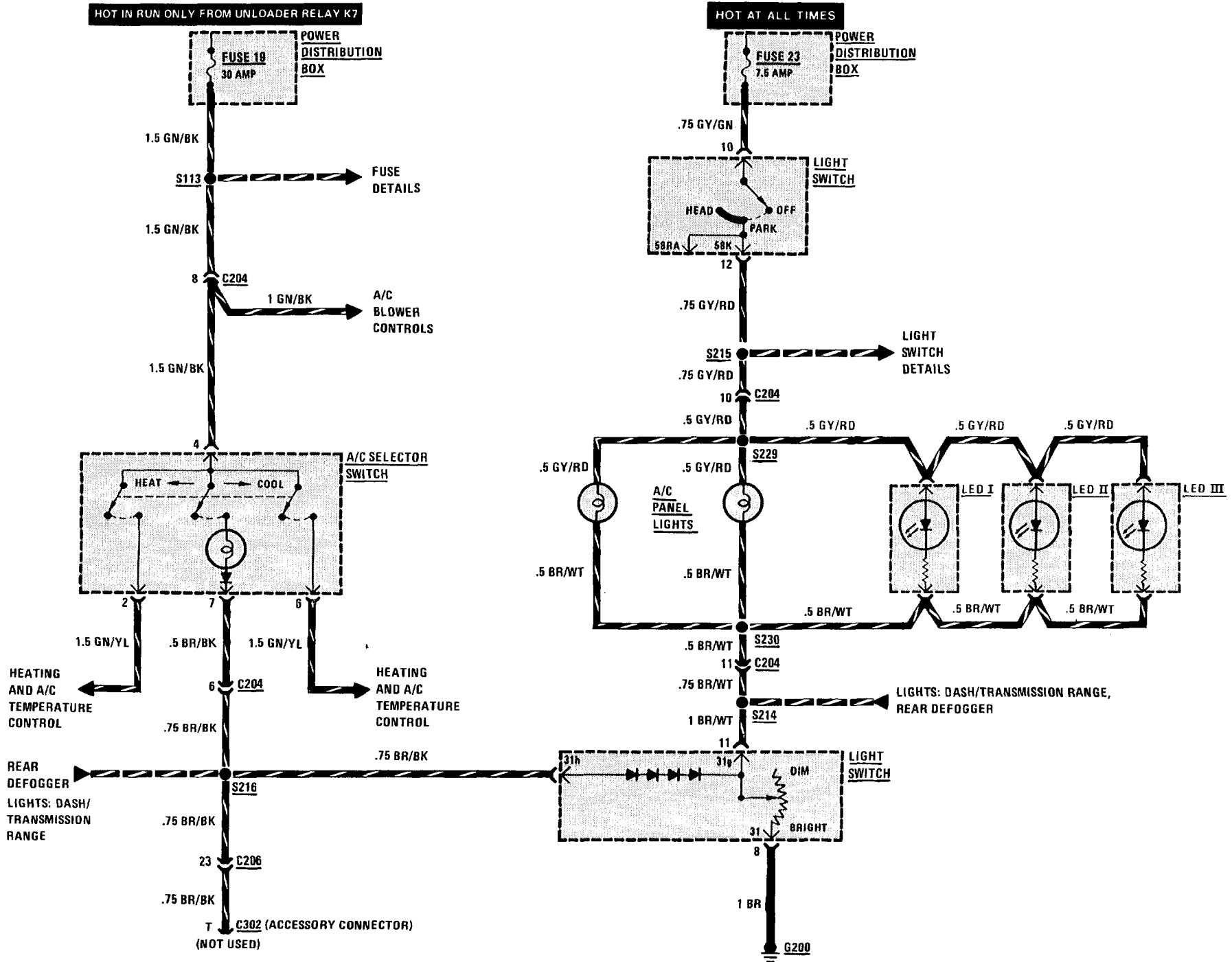

HEATING AND A/C TEMPERATURE CONTROL

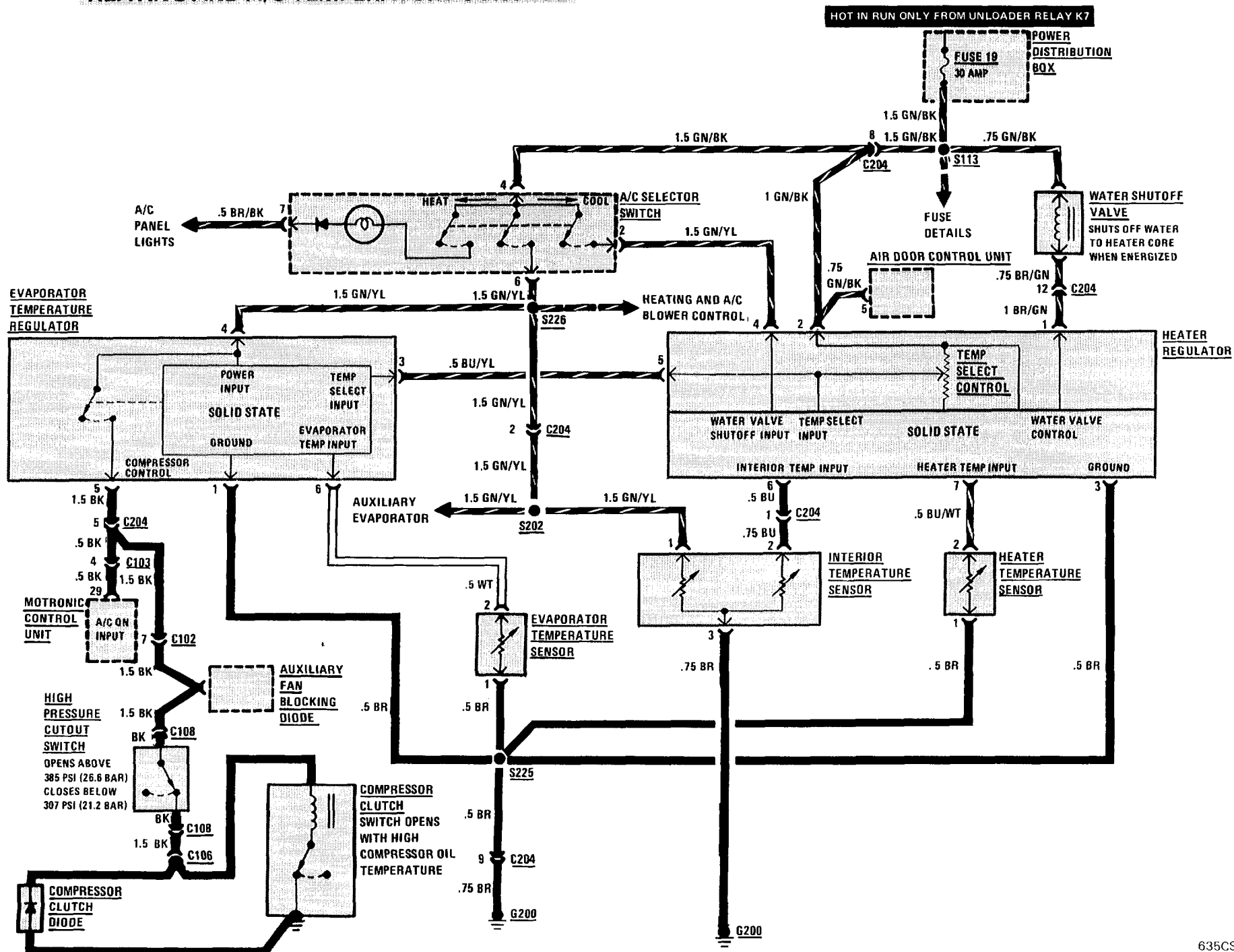

HEATING AND A/C BLOWER CONTROL

HOT IN RUN ONLY FROM UNLOADER RELAY K7

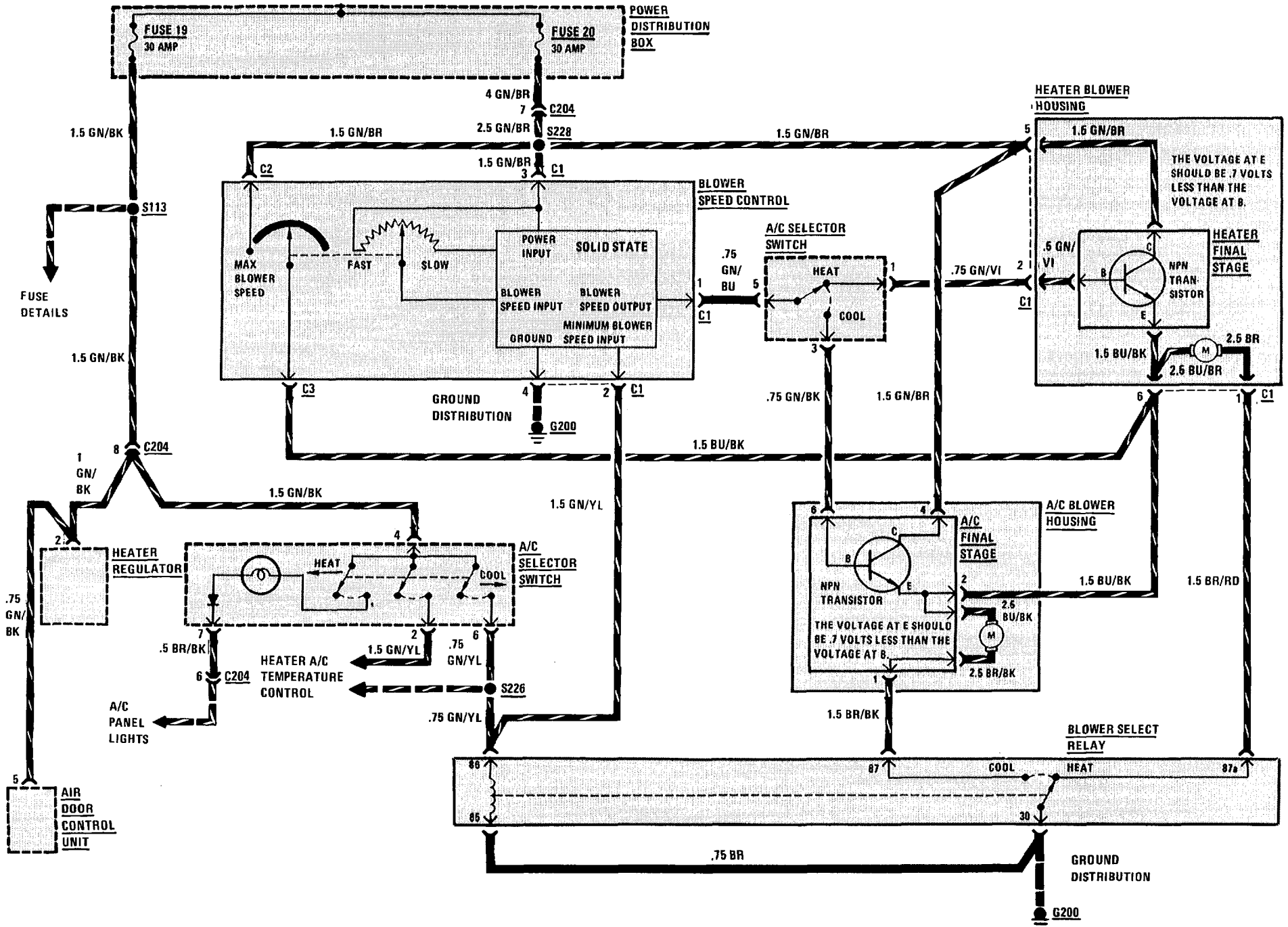

HEATING AND A/C BLOWER CONTROL

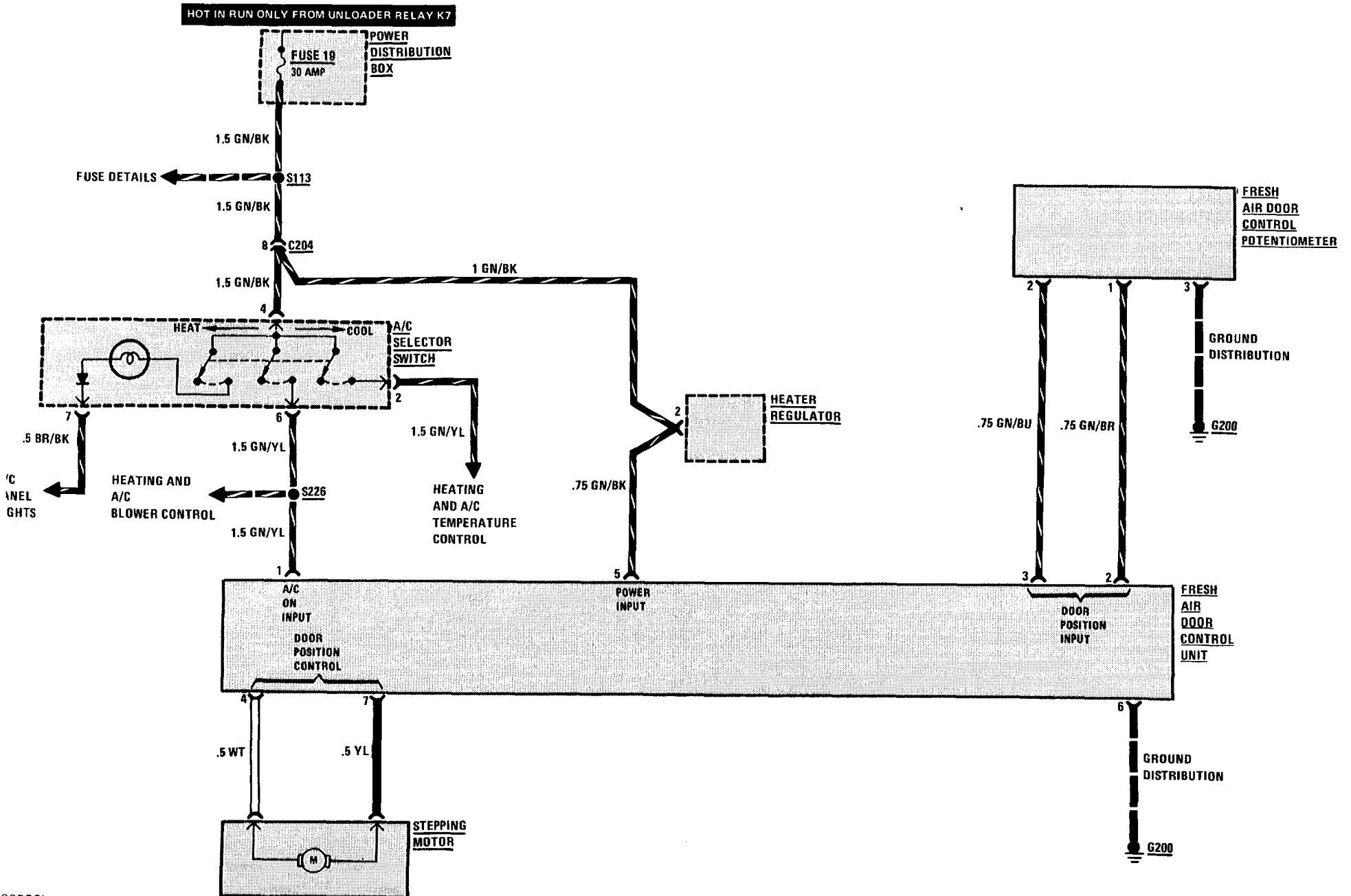

# 6414-0 REAR A/C EVAPORATOR

**LATE PRODUCTION ONLY**

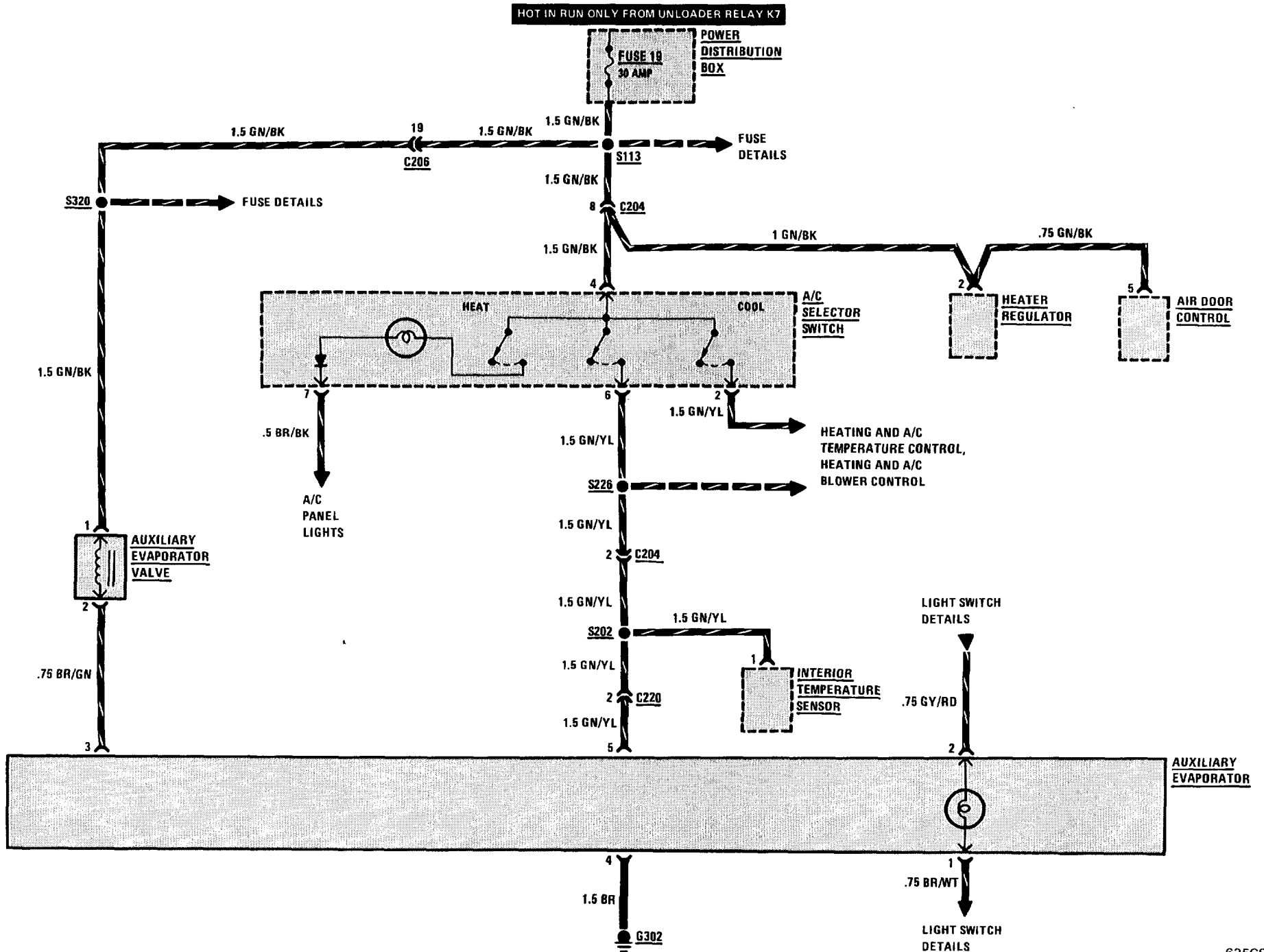





# 6500-0 RADIO/POWER ANTENNA

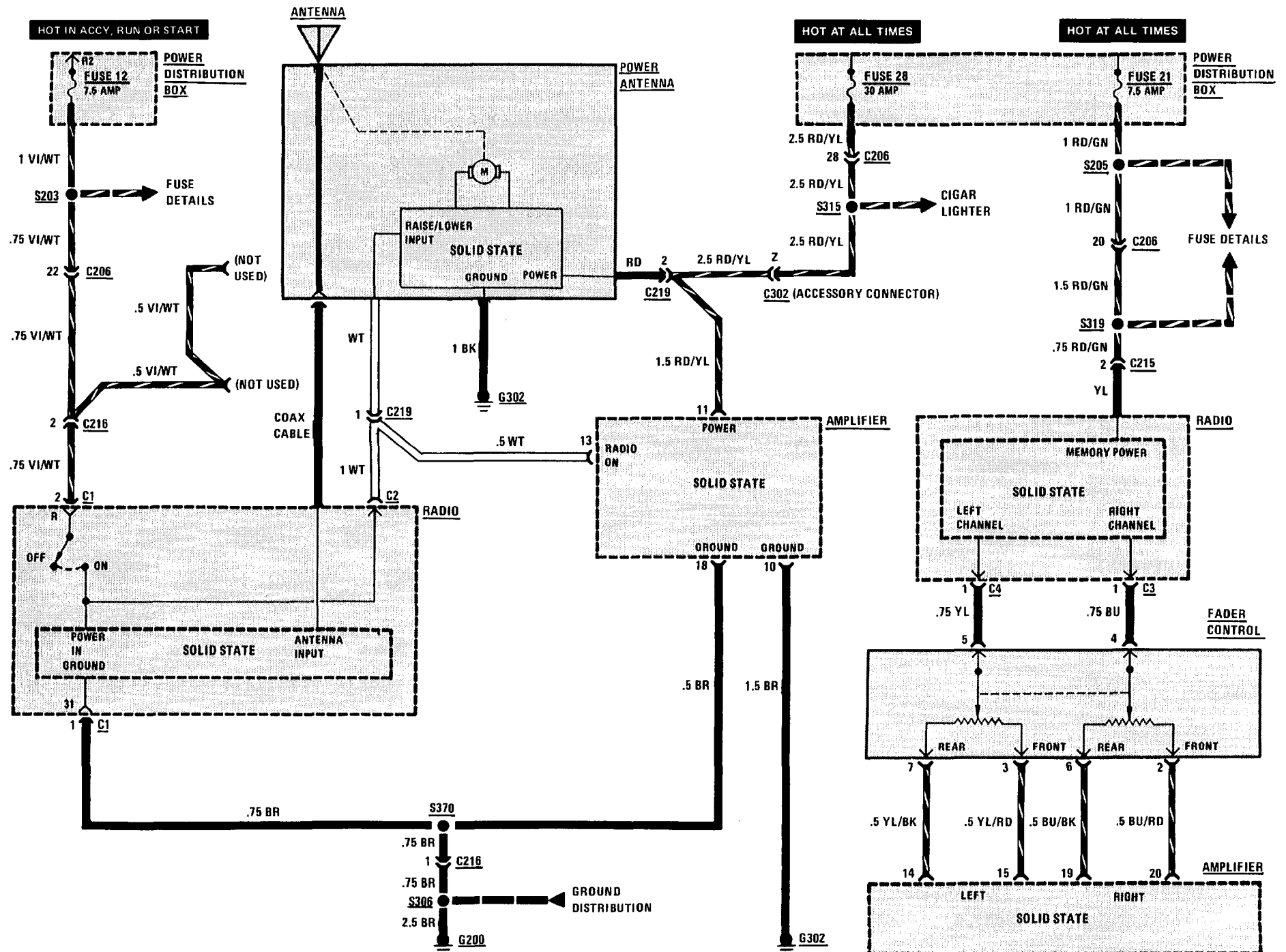

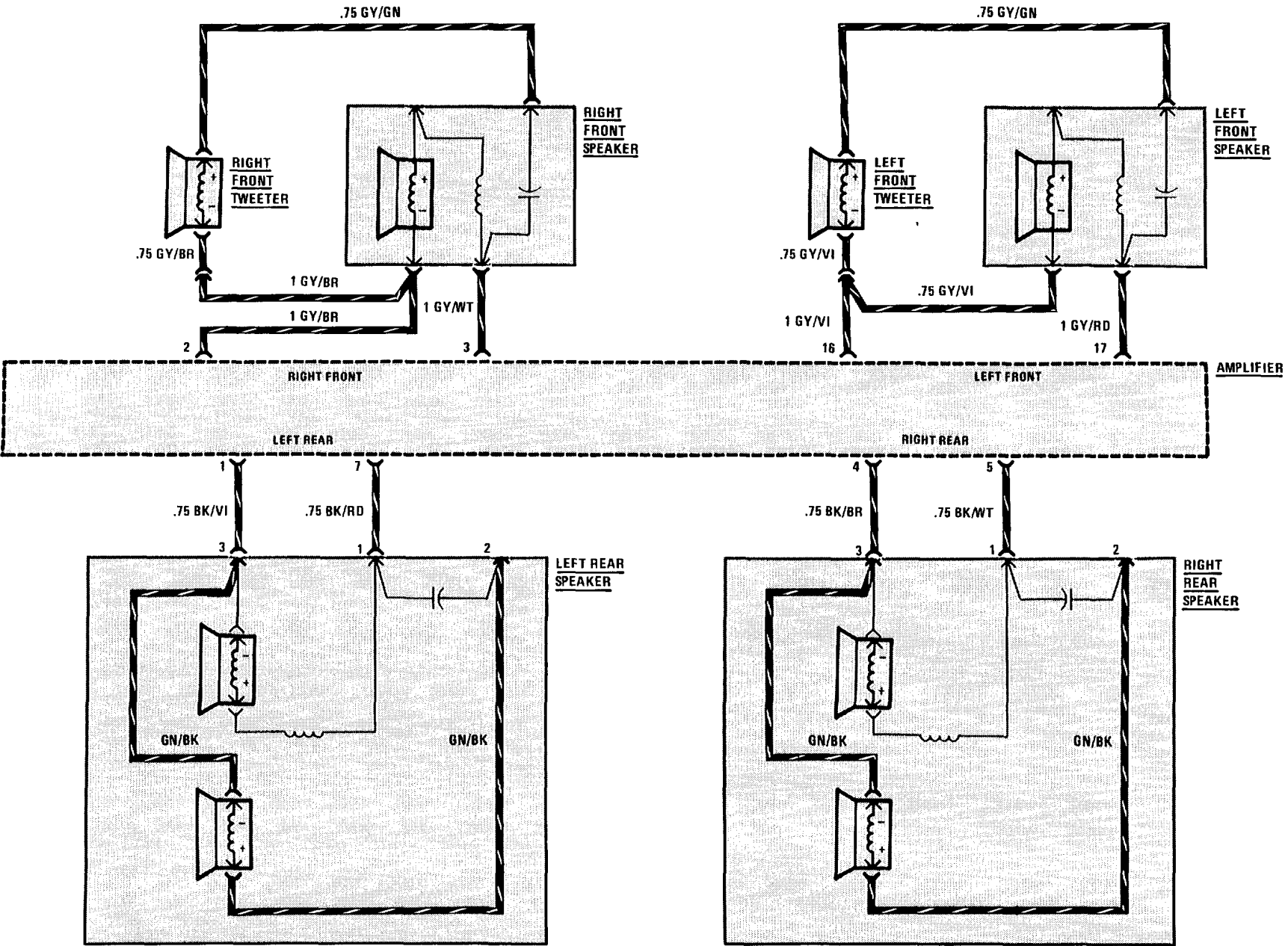

# 6571-0 CRUISE CONTROL

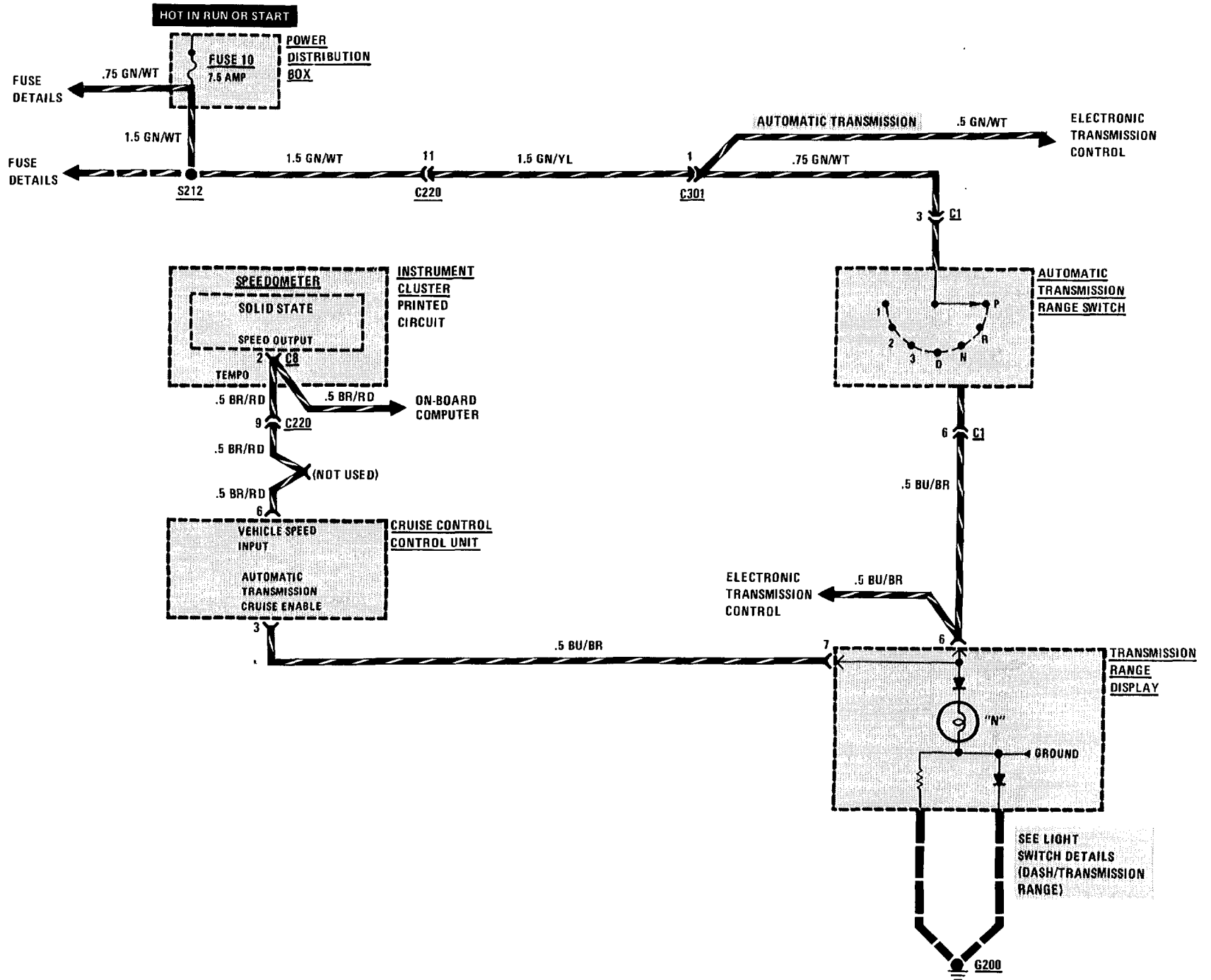

EARLY PRODUCTION

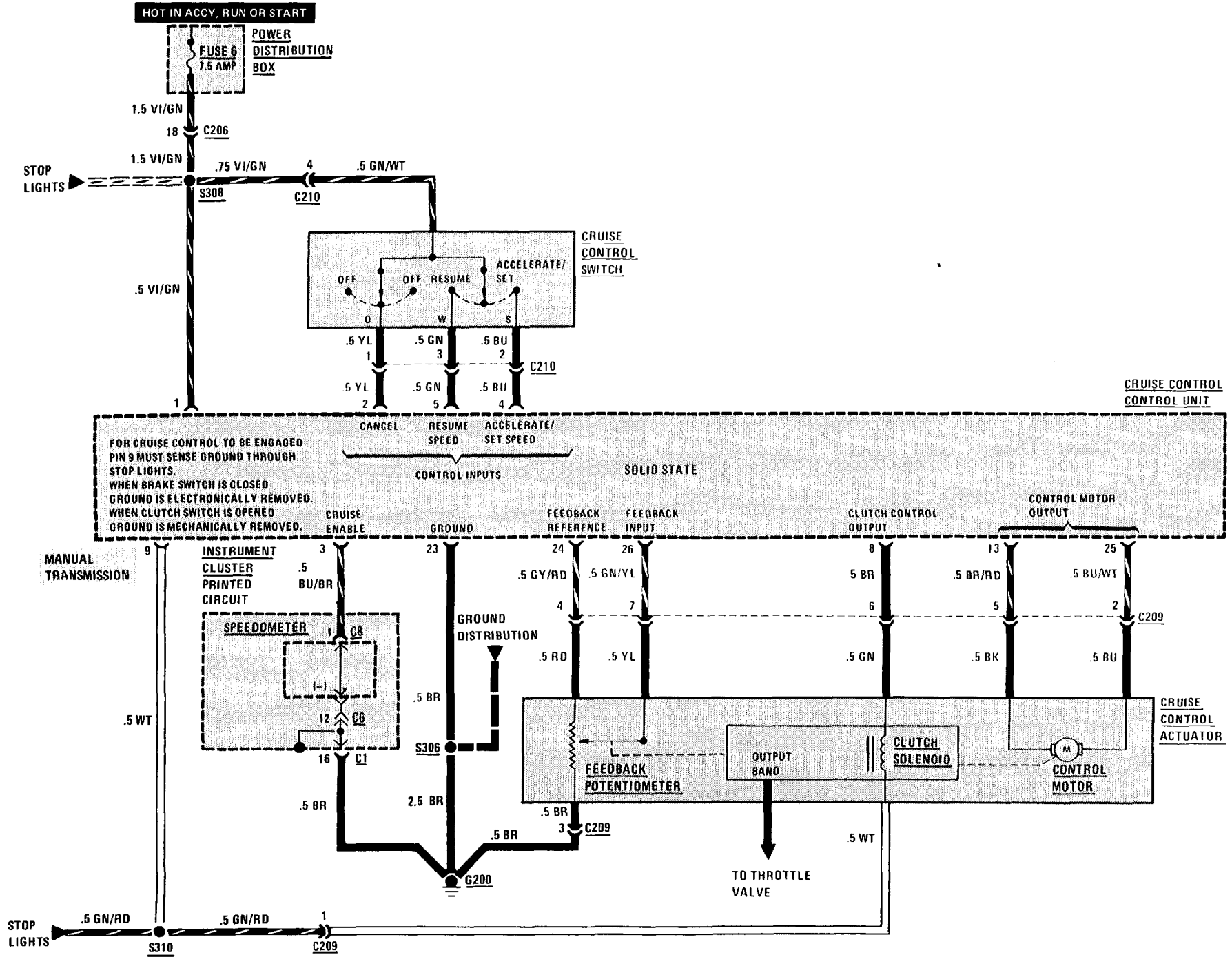

# 6571-2 CRUISE CONTROL

## LATE PRODUCTION

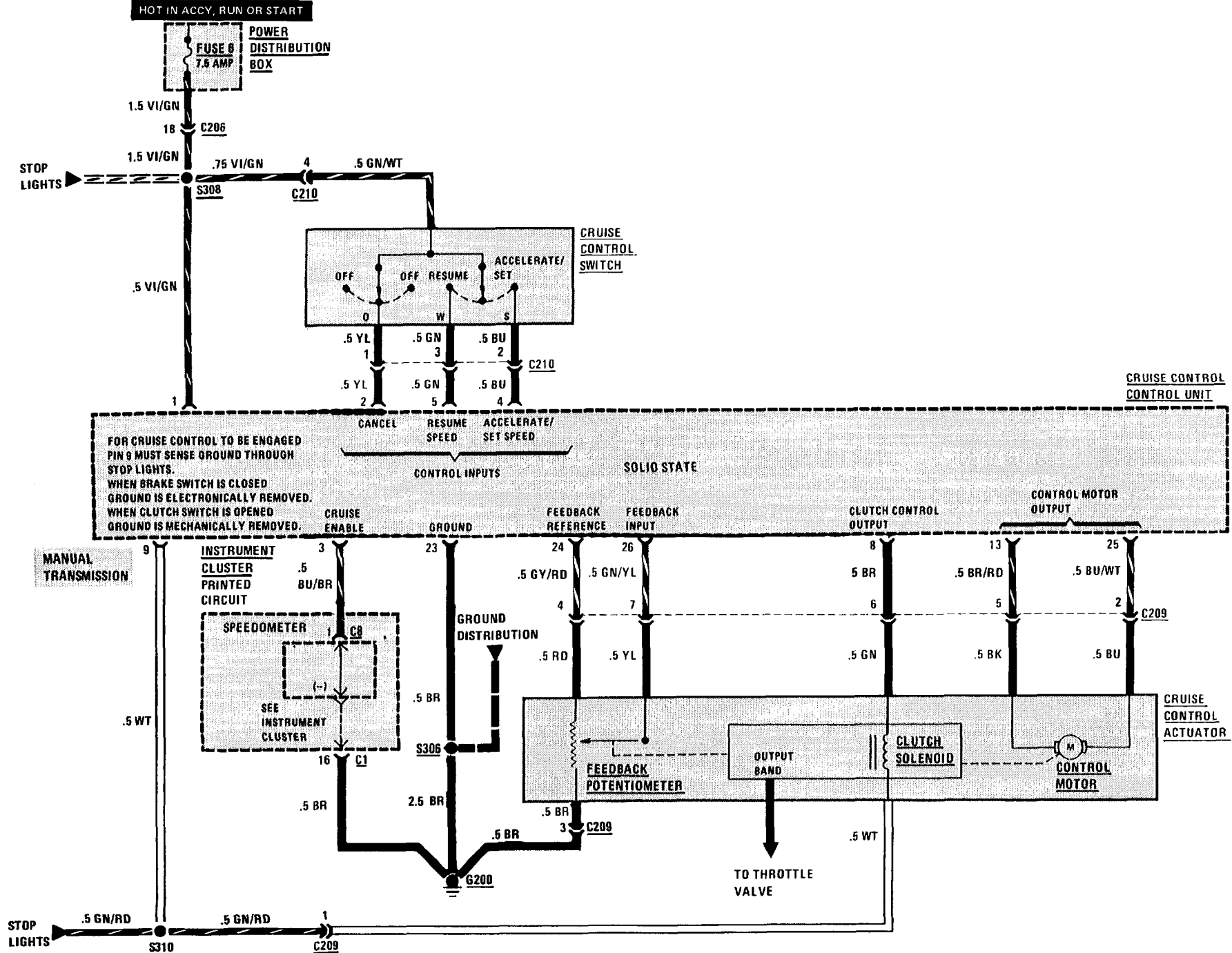

# 6581-0 ON-BOARD COMPUTER

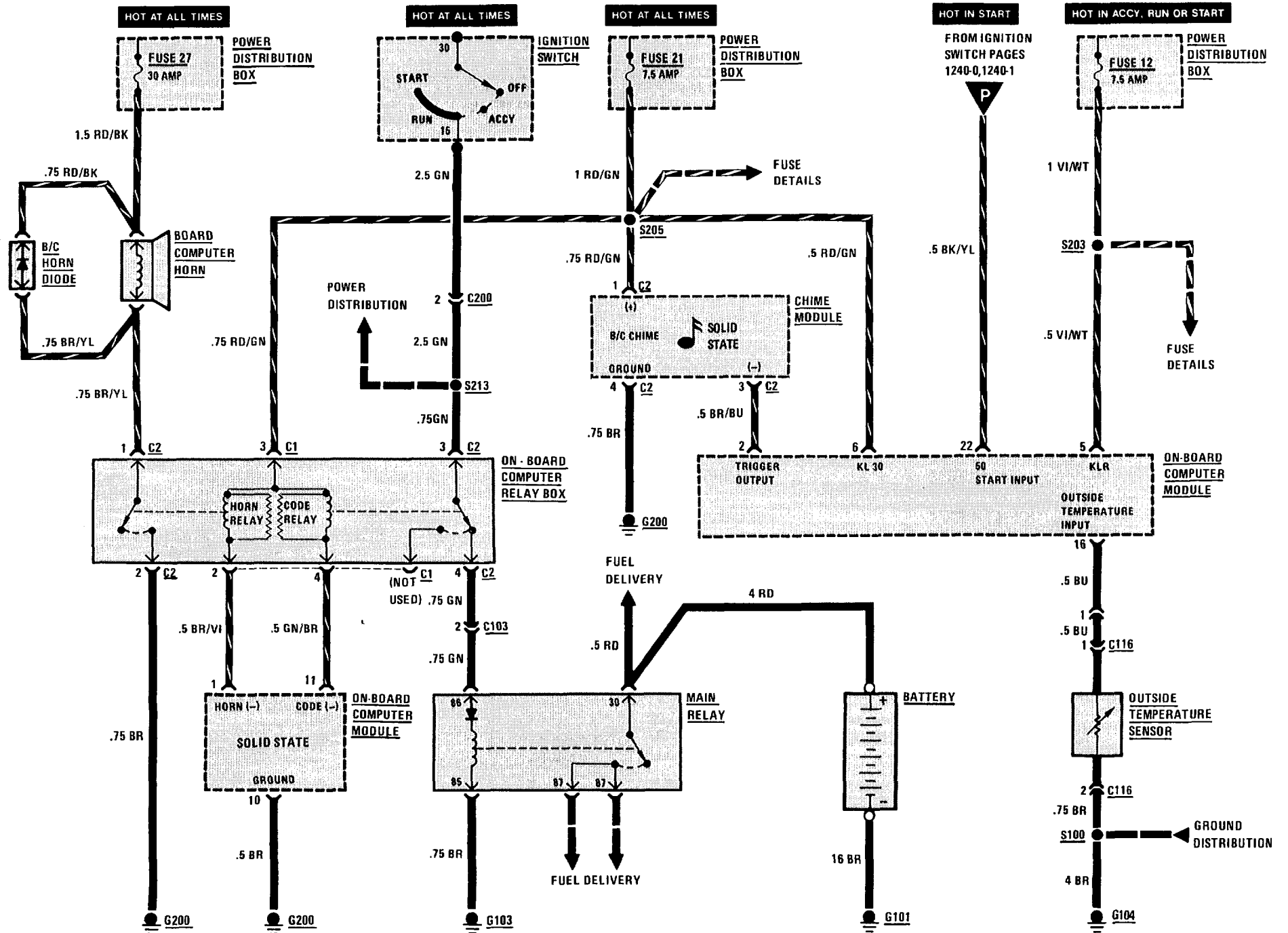

## EARLY PRODUCTION

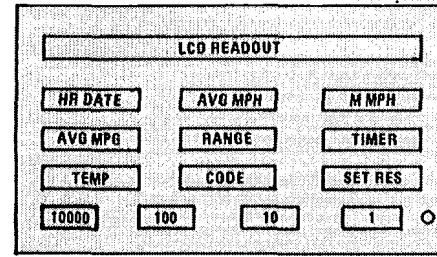

ON-BOARD COMPUTER MODULE (FRONT VIEW)

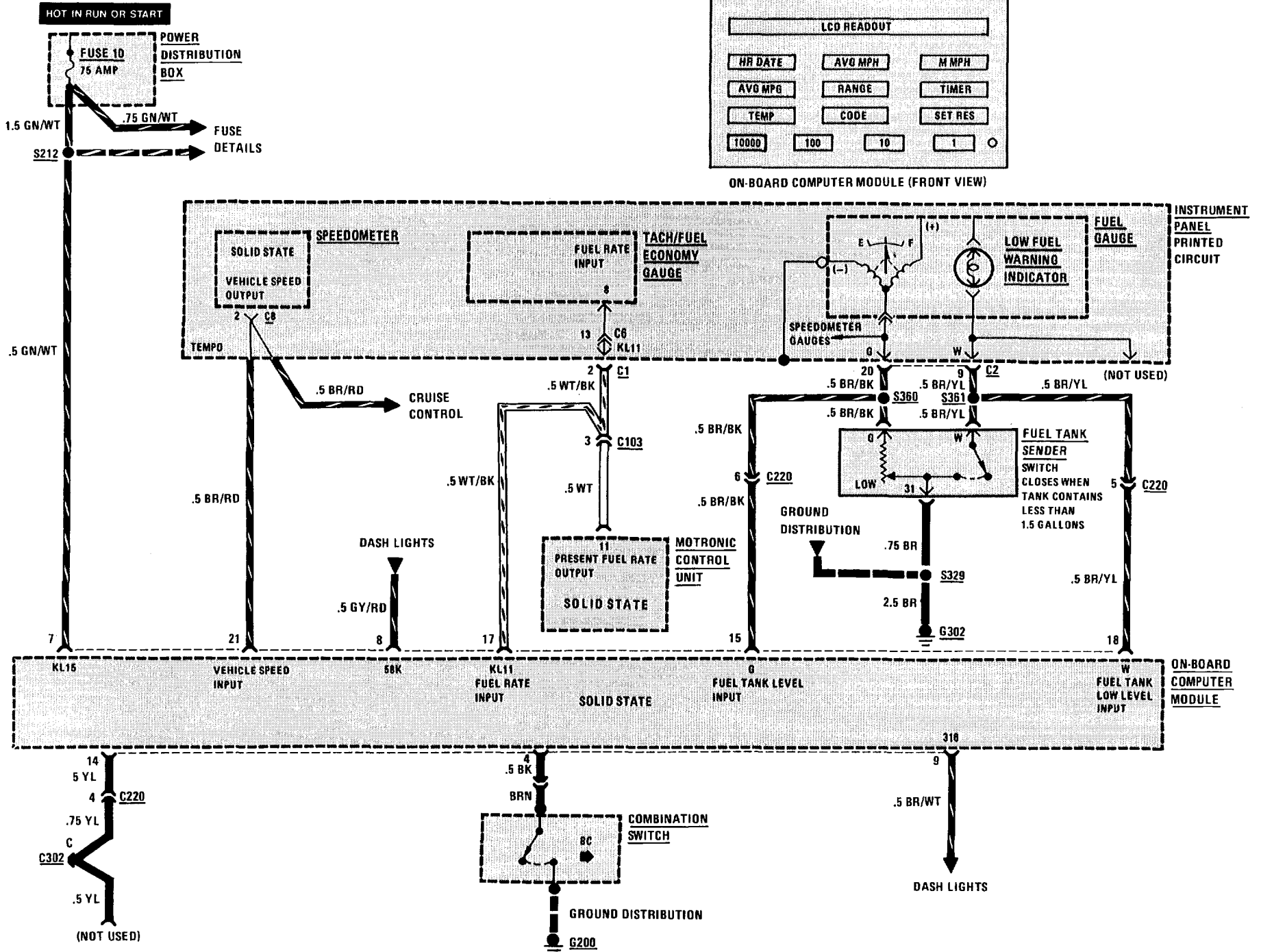

# 6581-2 ON-BOARD COMPUTER

## LATE PRODUCTION

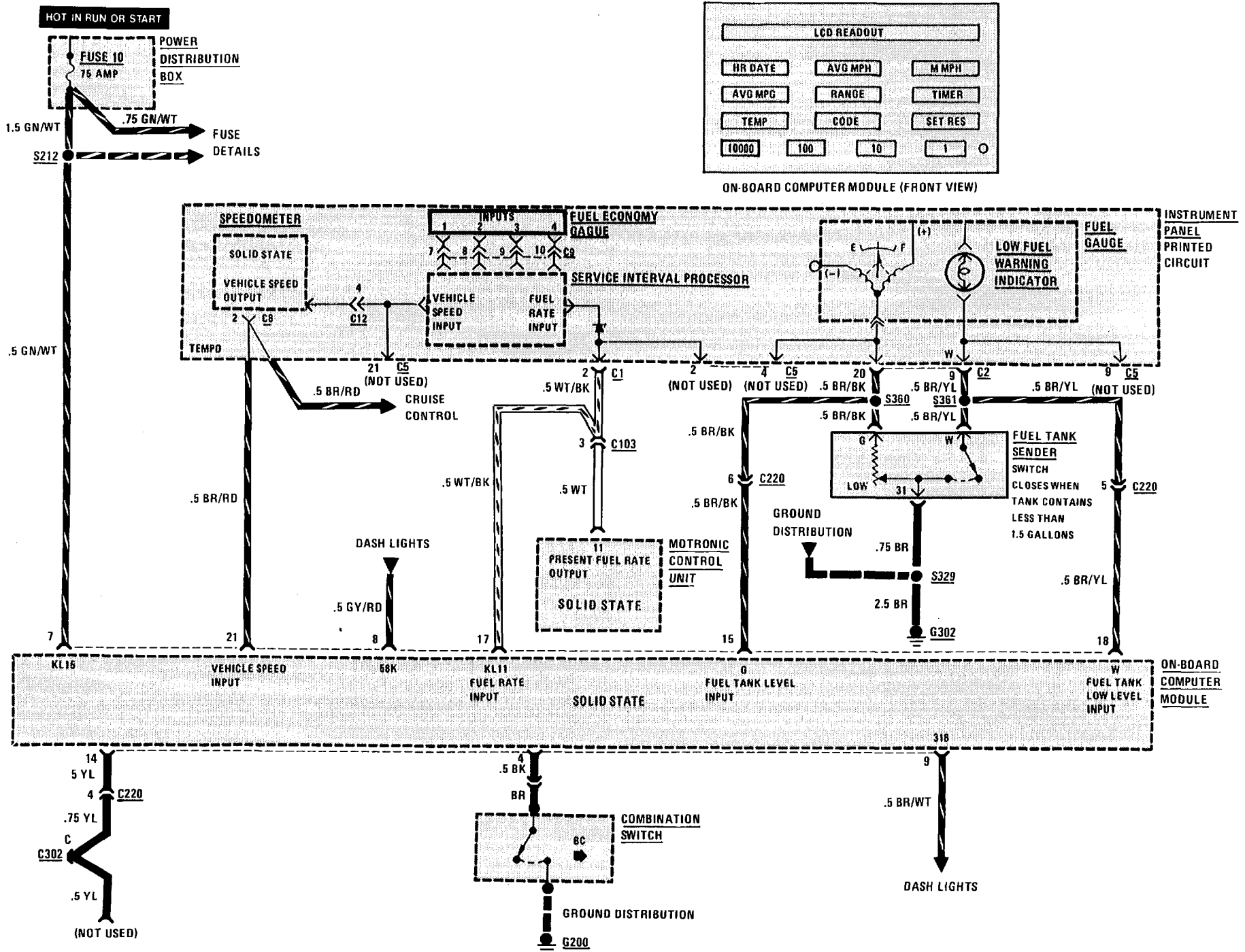



# 7000-0 COMPONENT LOCATION VIEWS

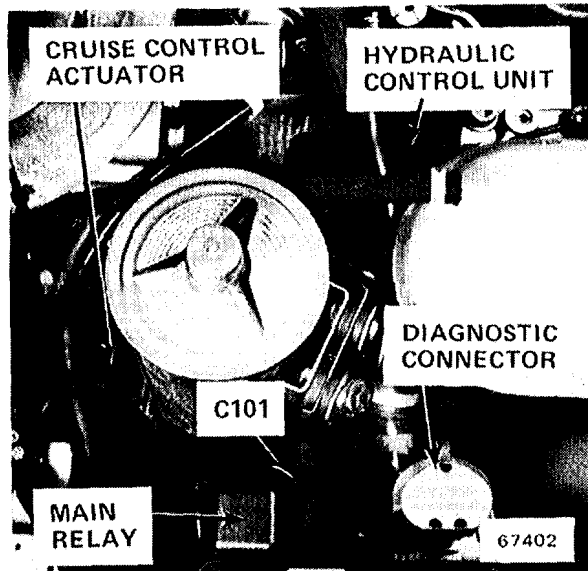

Figure 1 - Right of Left Front Wheel Well

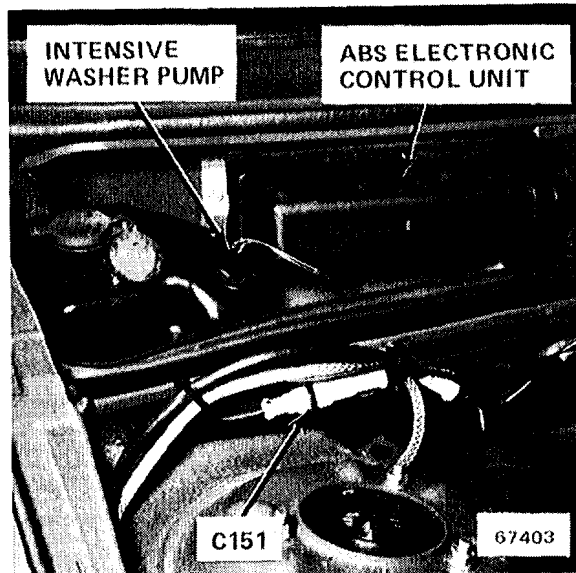

Figure 3 - RH Rear Corner of Engine Compartment

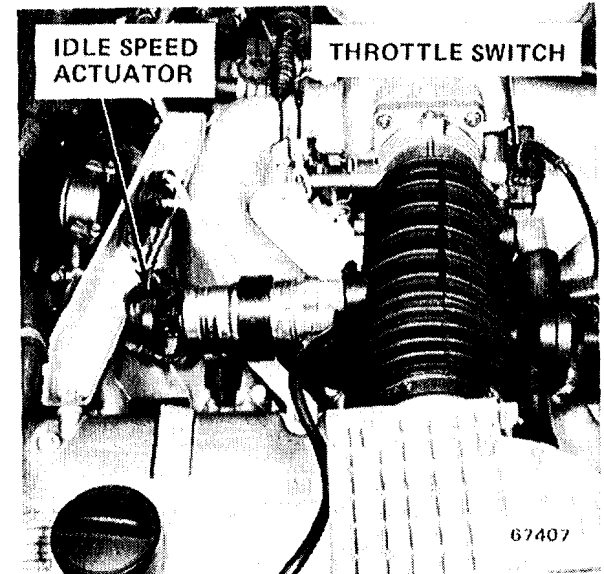

Figure 5 - Top Center of Engine

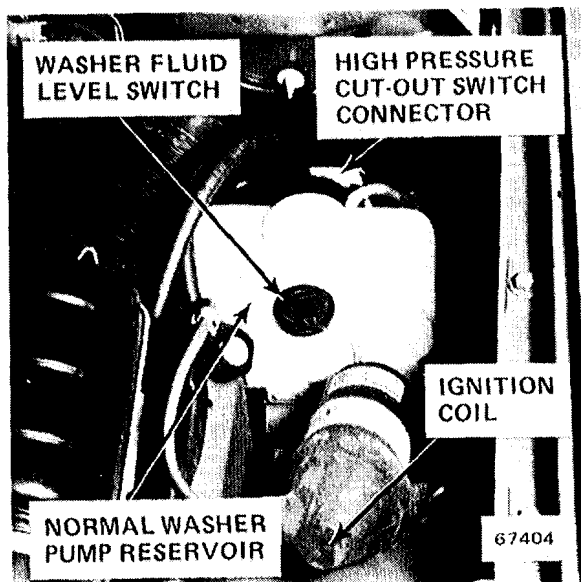

Figure 2 - Ahead of Right Front Wheel Well

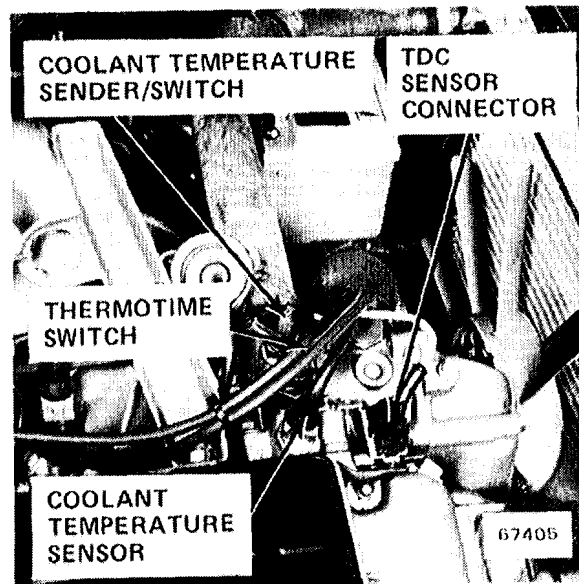

Figure 4 - Top Front of Engine

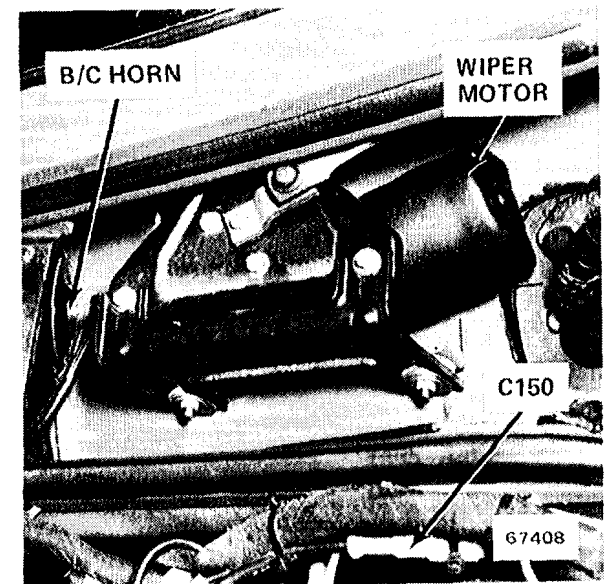

Figure 6 - Under Left Side of Cowl

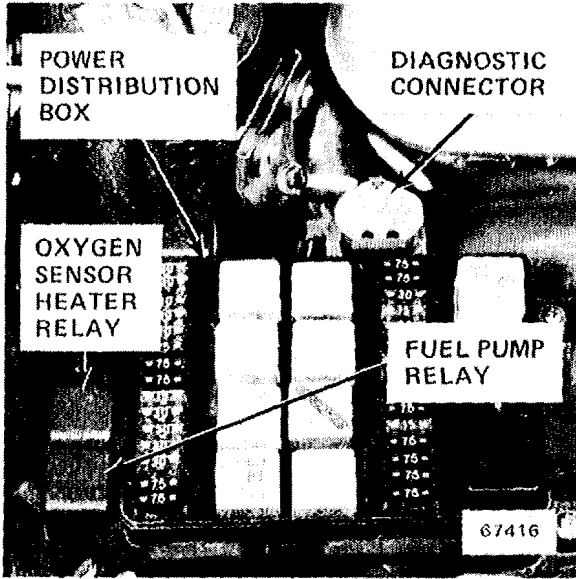

Figure 1 - Top of Left Front Wheel Well

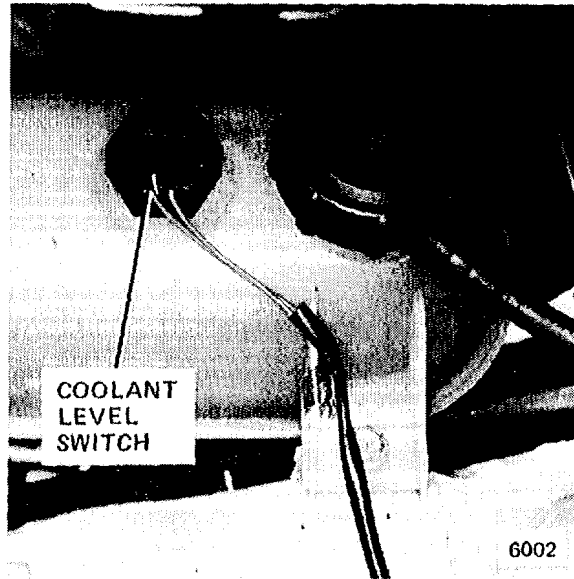

Figure 3 - Right of Left Front Wheel Well

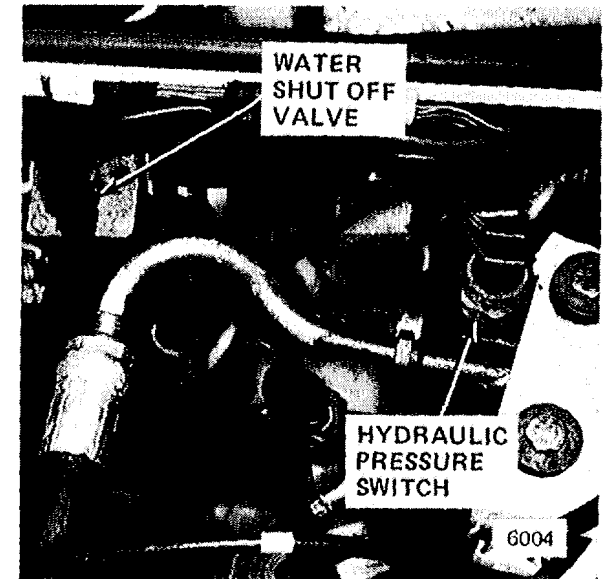

Figure 5 - Left Rear Corner of Engine Compartment

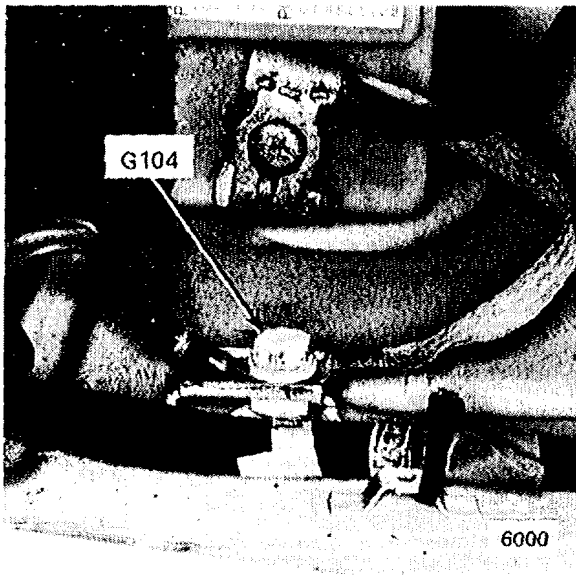

Figure 2 - Inner Fender, Left of Battery

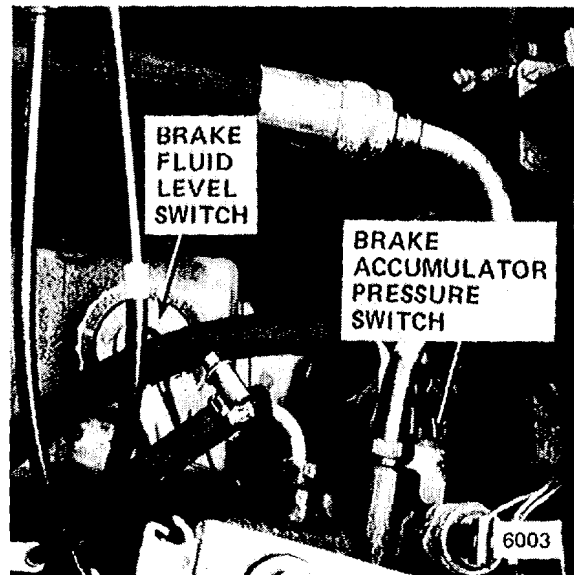

Figure 4 - Left Rear Corner of Engine Compartment

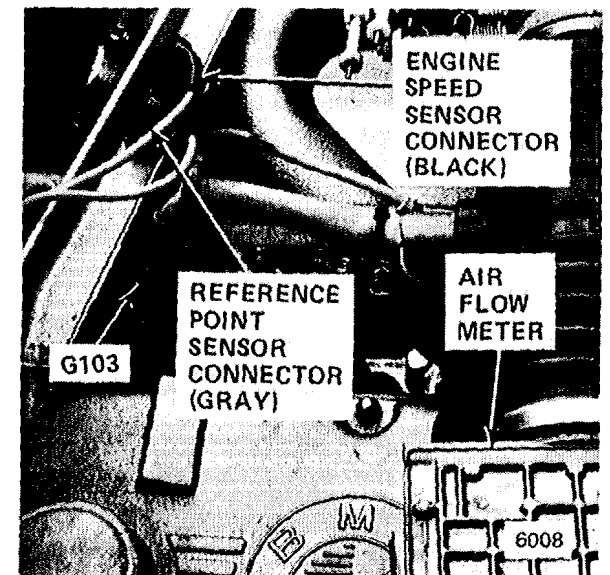

Figure 6 - Top Rear of Engine

# 7000-2 COMPONENT LOCATION VIEWS

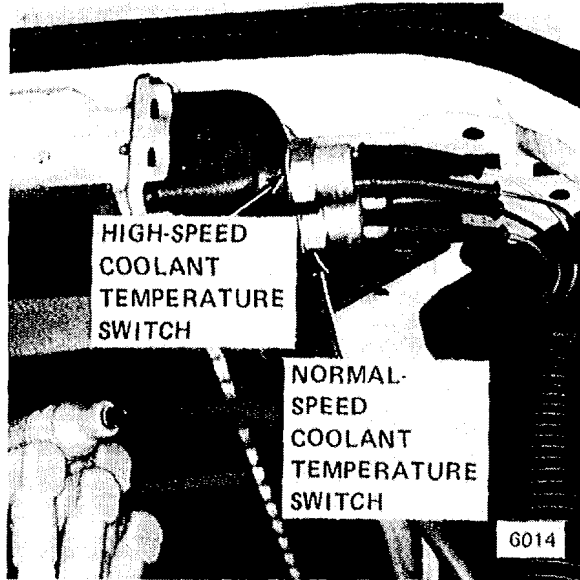

Figure 1 - Top Right Side of Radiator

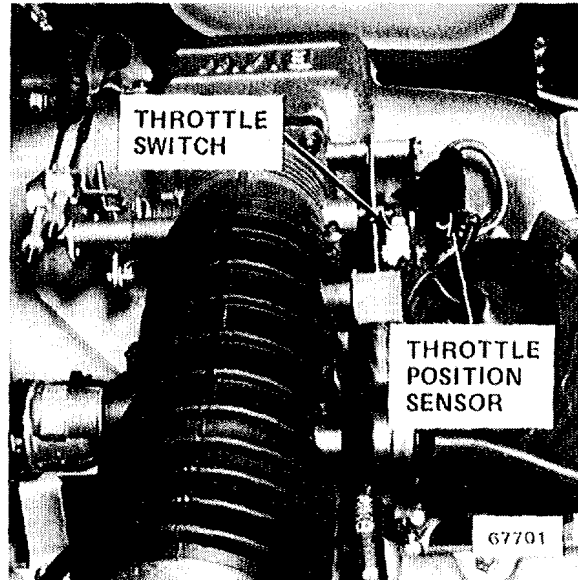

Figure 3 - Top Center of Engine

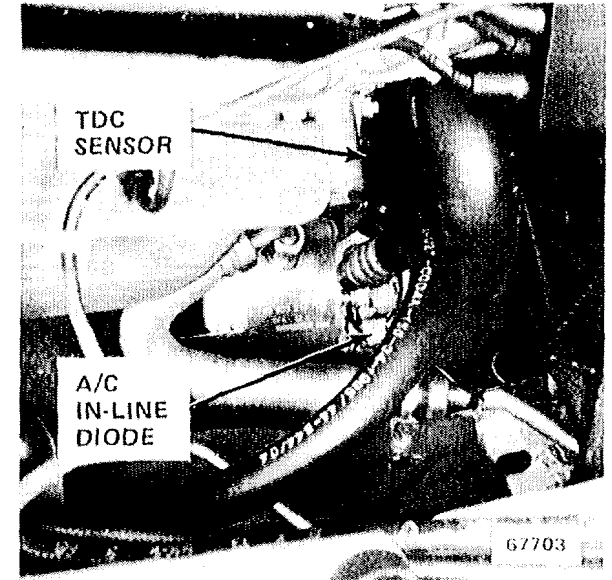

Figure 5 - RH Front of Engine

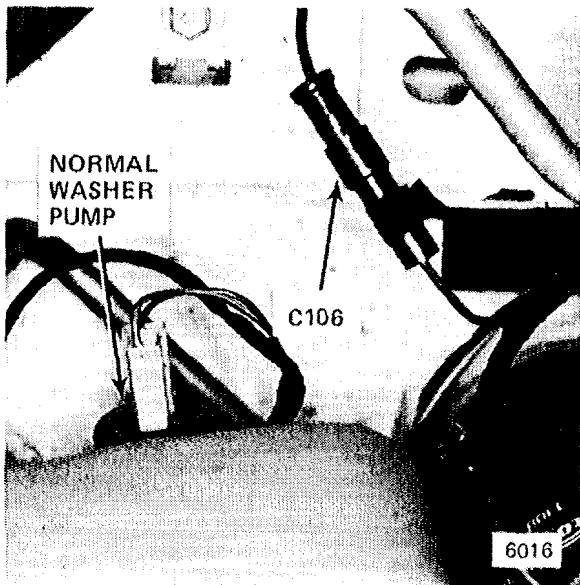

Figure 2 - Ahead of Right Front Wheel Well



Figure 4 - Rear of Engine

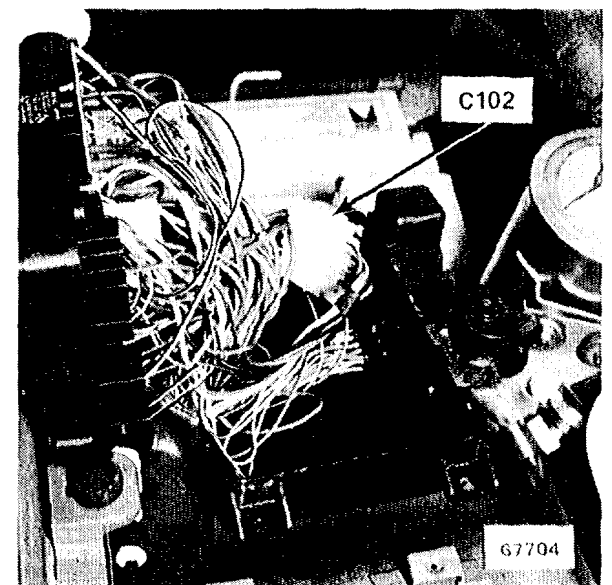

Figure 6 - LH Front Wheel Well

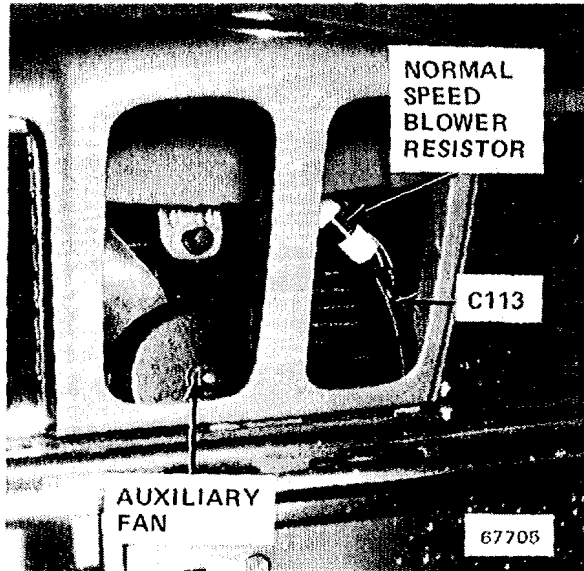

Figure 1 - Front of Car  
(Center Grills Removed)



Figure 3 - Behind Left Side of Console

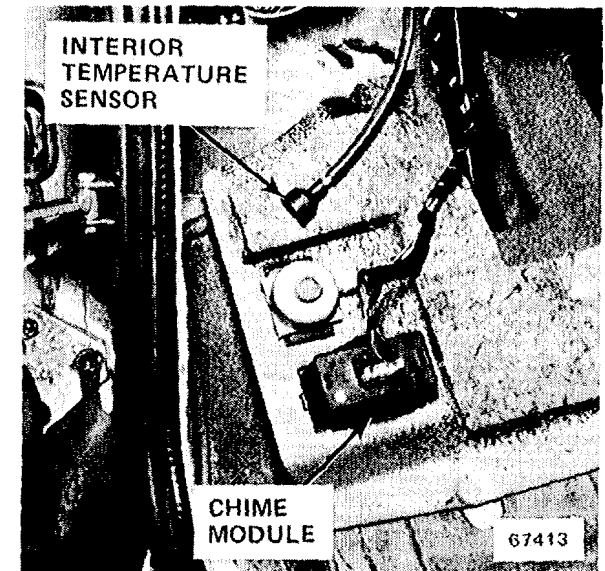

Figure 5 - Behind Dash, Left of Steering Column



Figure 2 - Driver's Footwell, Above Brake Pedal

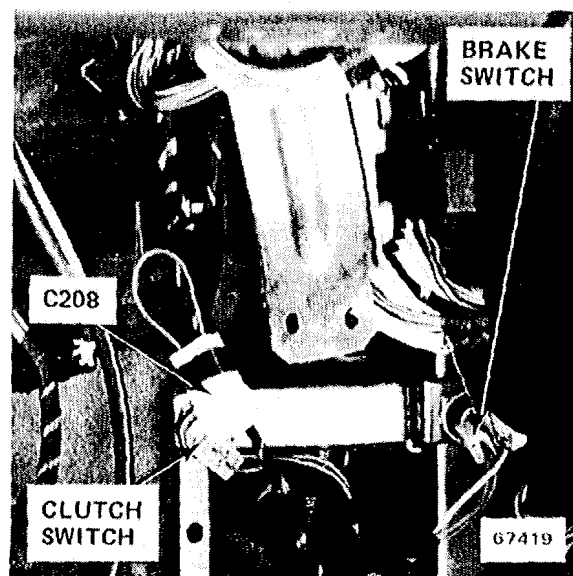

Figure 4 - Driver's Footwell, Above Brake Pedal

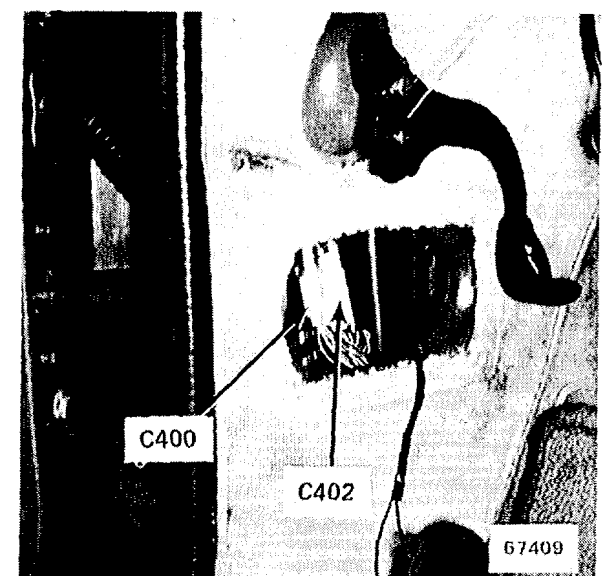

Figure 6 - LH Front Kick Panel

# 7000-4 COMPONENT LOCATION VIEWS

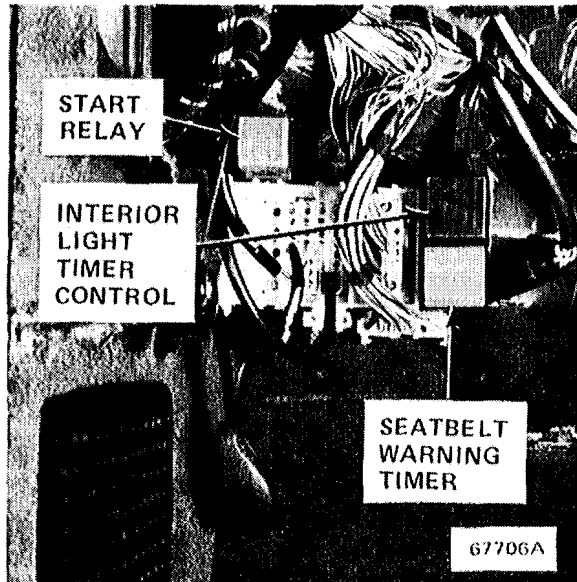

Figure 1 - Near LH Front Kick Panel

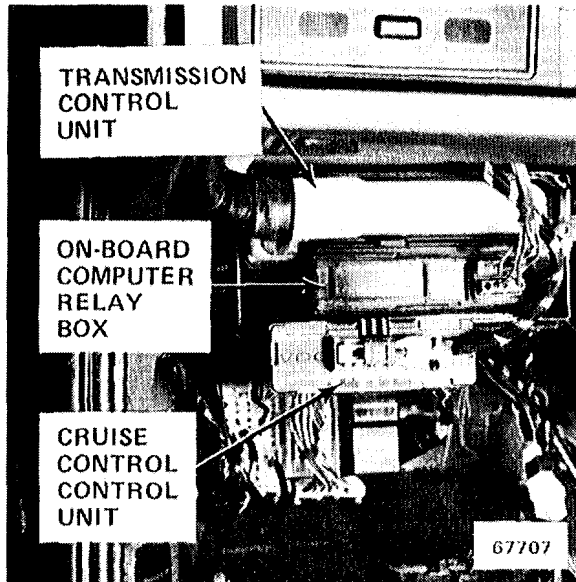

Figure 3 - Above LH Front Kick Panel

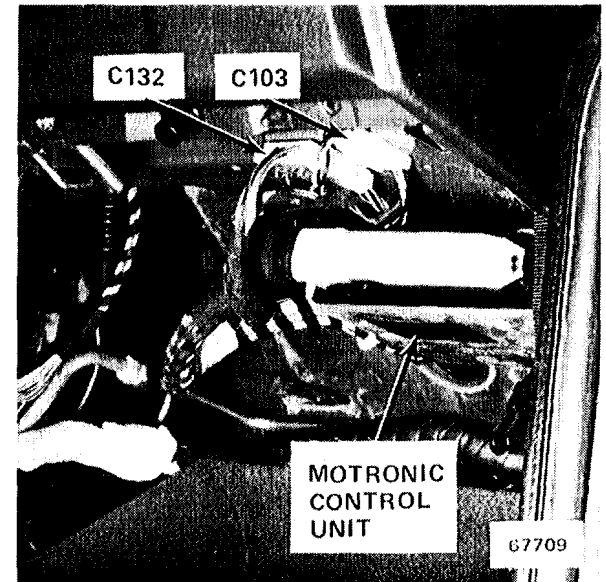

Figure 5 - Above Glove Box

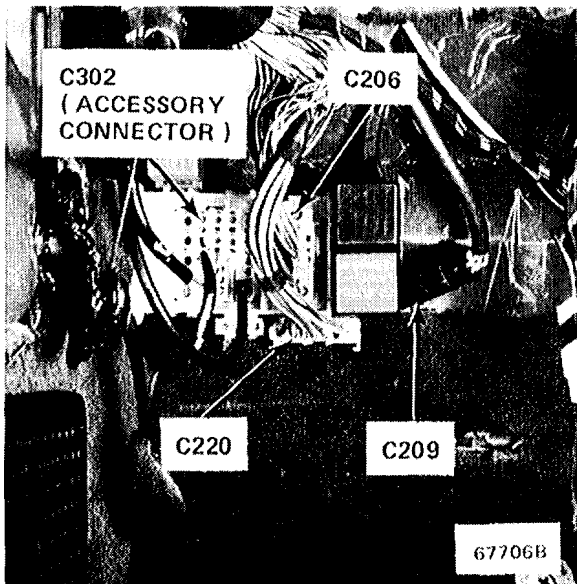

Figure 2 - Near LH Front Kick Panel

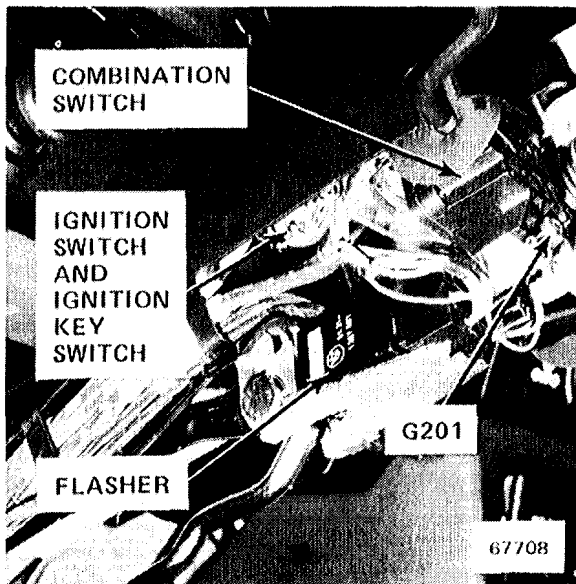

Figure 4 - Underside of Steering Column

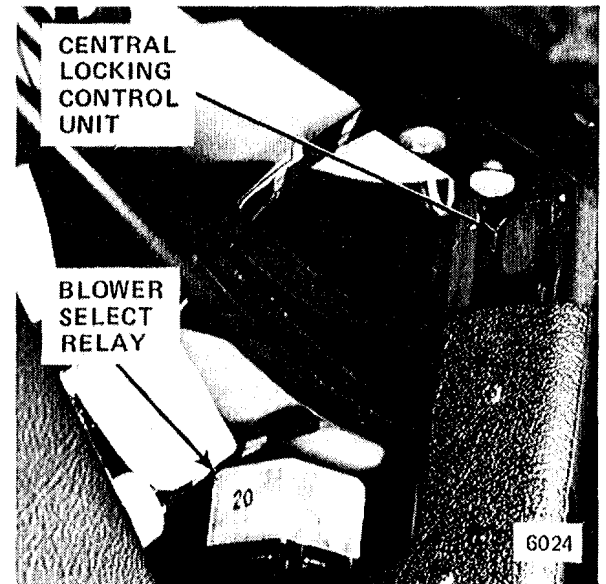

Figure 6 - Behind Dash, Left of Glove Box

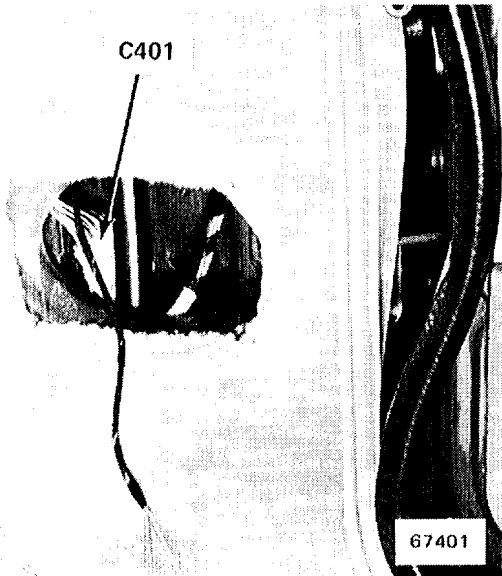

Figure 1 - RH Front Kick Panel

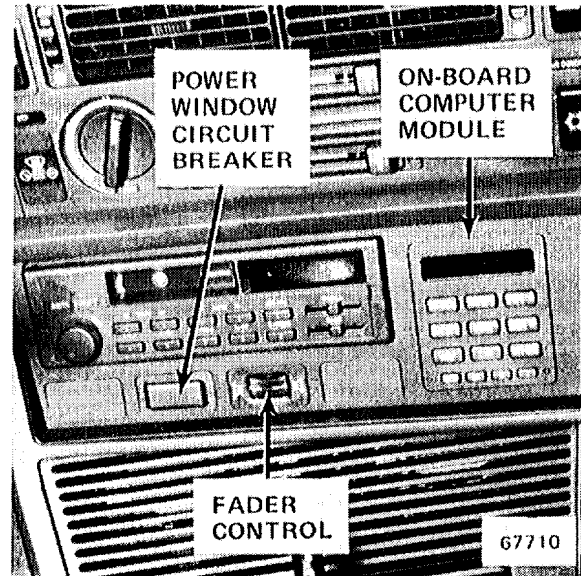

Figure 3 - Center Console

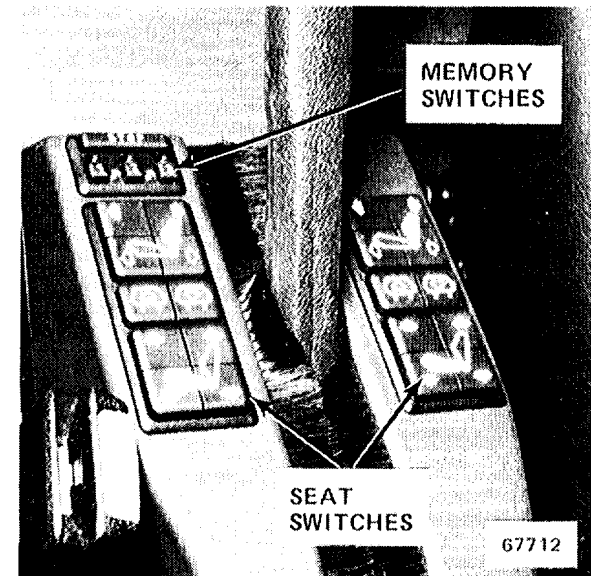

Figure 5 - Center Console

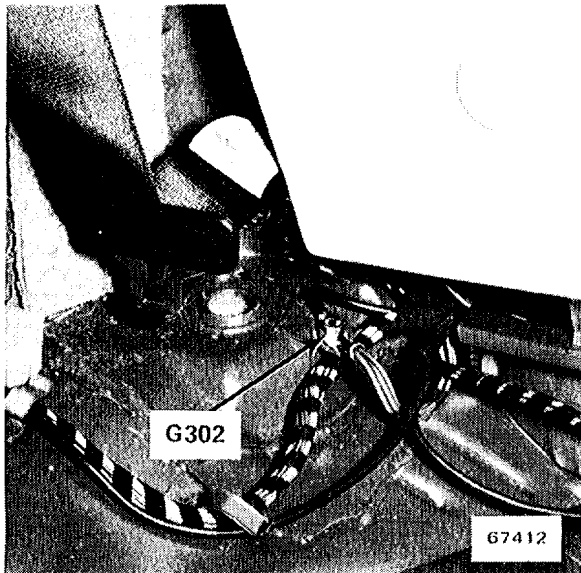

Figure 2 - Under LH Side of Rear Seat

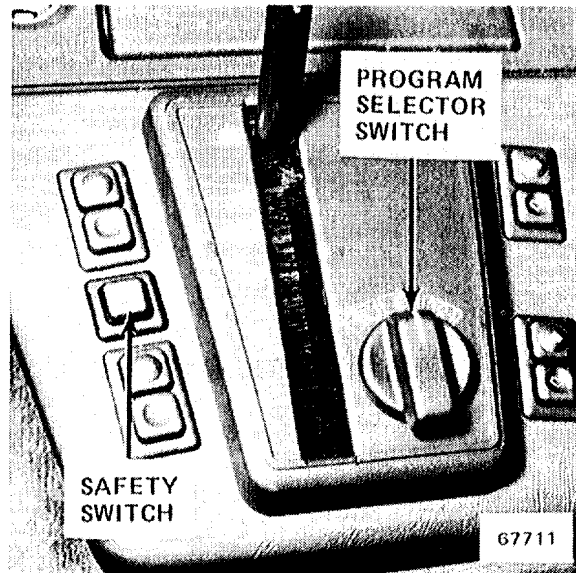

Figure 4 - Center Console

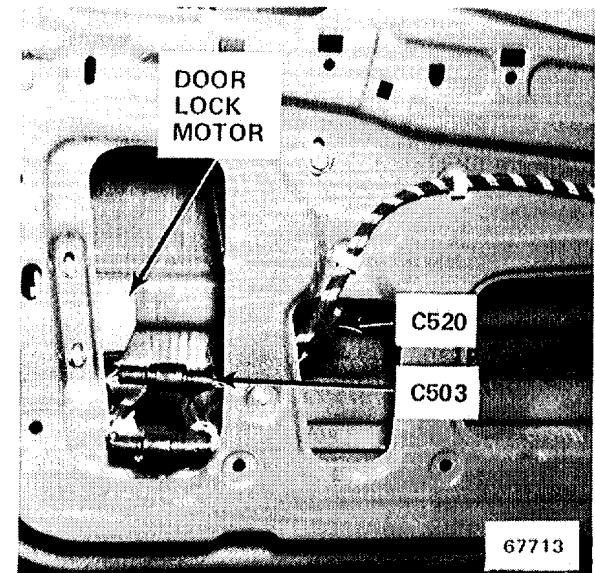

Figure 6 - Inside Driver's Door

# 7000-6 COMPONENT LOCATION VIEWS

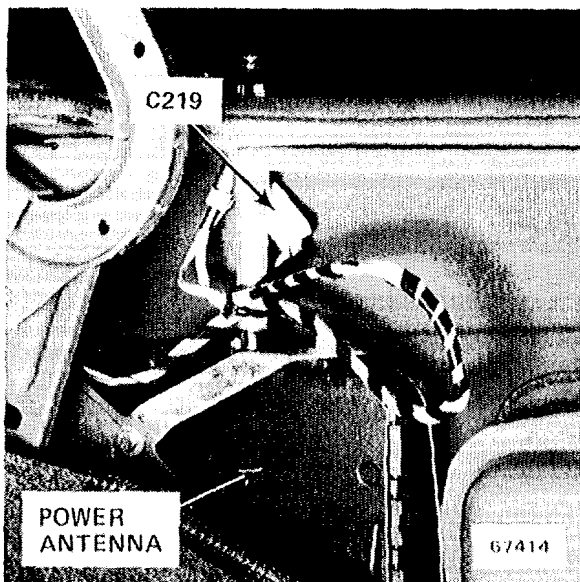

Figure 1 - RH Side of Trunk

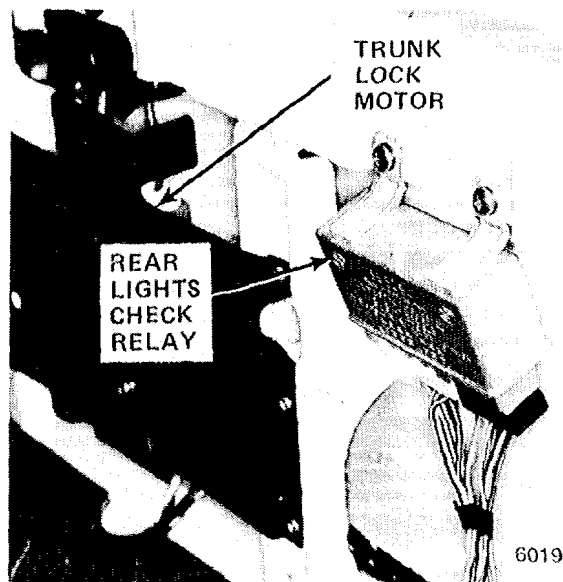

Figure 3 - Rear Panel of Trunk

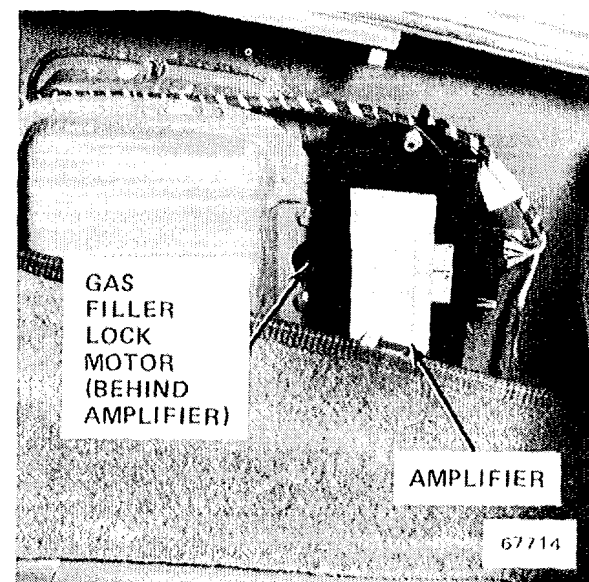

Figure 5 - Right Side of Trunk

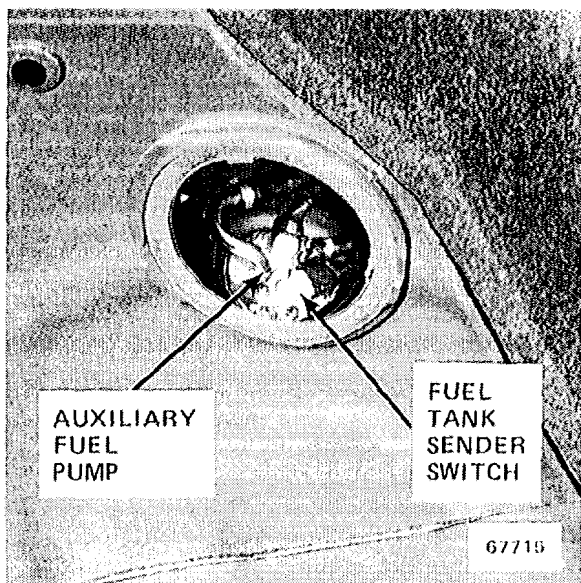

Figure 2 - RH Side of Trunk Floor

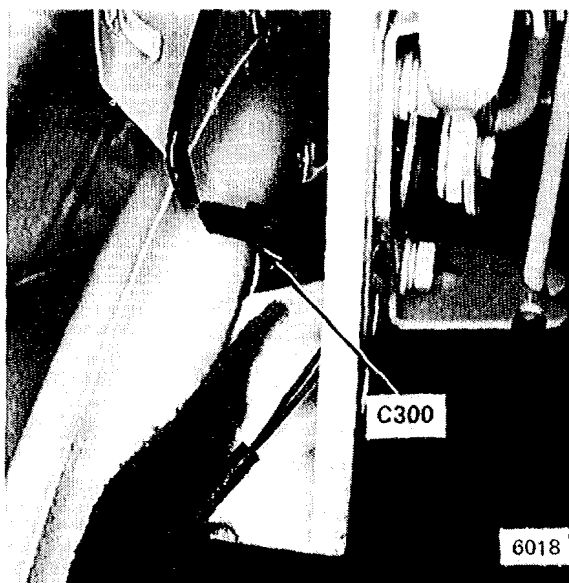

Figure 4 - Left Trunk Hinge

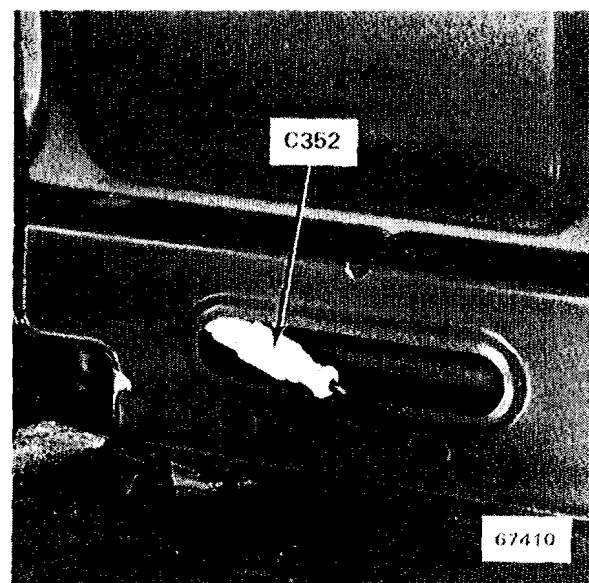

Figure 6 - LH Front of Trunk

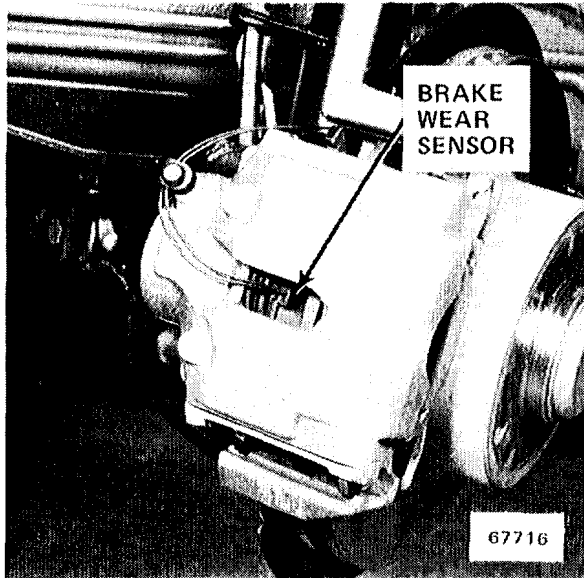

Figure 1 - LH Front Brake Assembly  
(RH Rear Similar)

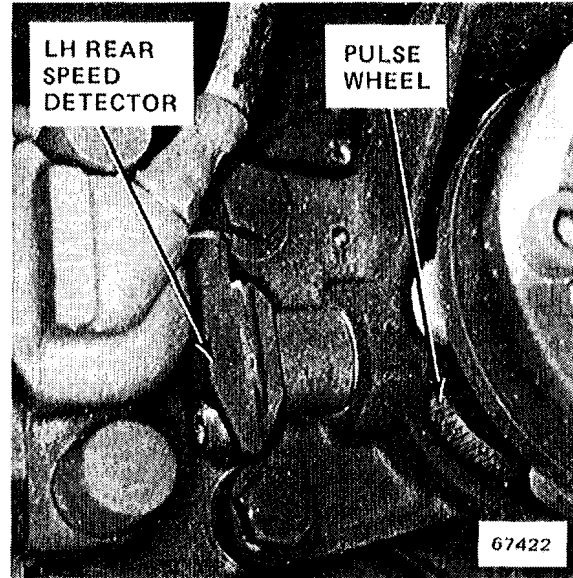

Figure 3 - Back of Left Rear Wheel

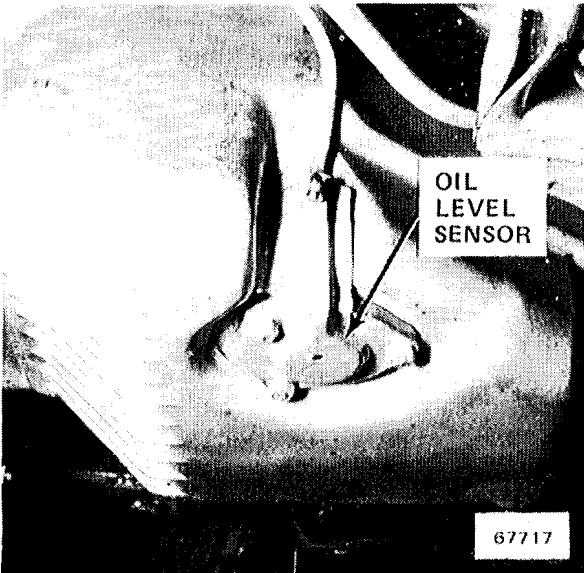

Figure 2 - Bottom of Oil Pan

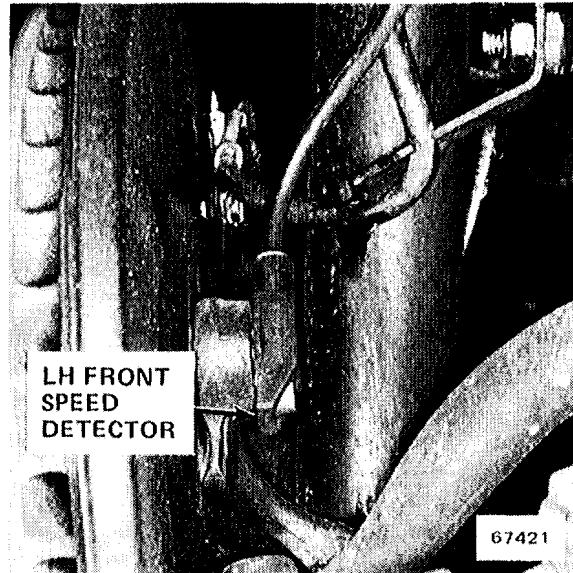

Figure 4 - Back of Left Front Wheel



## 8000-0 SPLICE LOCATION VIEWS

### SPLICE LOCATION INDEX

This index contains all the splices in the car, what harness each one is in, and the page that the splices appear on. The drawings after the index show how the harness is routed through the car and where the splices are located on the harness.

#### Index-Splice Locations 635

SPLICE	HARNESS	PAGE NUMBER	SPLICE	HARNESS	PAGE NUMBER	SPLICE	HARNESS	PAGE NUMBER
S100	FRONT	8000-1	S215	MIDDLE	8000-2	S325	REAR	8000-4
S101	FRONT	8000-1	S216	MIDDLE	8000-2	S326	REAR	8000-4
S102	FRONT	8000-1	S217	MIDDLE	8000-2	S327	REAR	8000-4
S103	FRONT	8000-1	S221	REAR	8000-4	S328	REAR	8000-4
S104	FRONT	8000-1	S222	REAR	8000-4	S329	REAR	8000-4
S105	ENGINE	8000-3	S223	REAR	8000-4	S330	REAR	8000-4
S106	ENGINE	8000-3	S225	A/C	NOT SHOWN	S331	REAR	8000-4
S108	ENGINE	8000-3				S332	REAR	8000-4
S109	ENGINE	8000-3	S226	A/C	NOT SHOWN	S333	REAR	8000-4
S110	ENGINE	8000-3				S334	REAR	8000-4
S111	MIDDLE	8000-2	S227	A/C	NOT SHOWN	S335	REAR	8000-4
S112	MIDDLE	8000-2				S336	REAR	8000-4
S113	MIDDLE	8000-2	S228	A/C	NOT SHOWN	S337	REAR	8000-4
S115	MIDDLE	8000-2				S338	REAR	8000-4
S116	MIDDLE	8000-2	S229	A/C	NOT SHOWN	S360	REAR	8000-4
S117	FRONT	8000-1				S361	REAR	8000-4
S118	WASHER JETS	NOT SHOWN	S230	A/C	NOT SHOWN	S362	REAR	8000-4
S119	WASHER JETS	NOT SHOWN	S300	REAR	8000-4	S370	SOUND SYSTEM	NOT SHOWN
			S301	REAR	8000-4	S409	DOOR	NOT SHOWN
S151	MIDDLE	8000-2	S302	REAR	8000-4			
S200	MIDDLE	8000-2	S303	REAR	8000-4	S502	DOOR	NOT SHOWN
S201	MIDDLE	8000-2	S306	REAR	8000-4			
S202	MIDDLE	8000-2	S307	REAR	8000-4	S550	POWER SEATS	NOT SHOWN
S203	MIDDLE	8000-2	S308	REAR	8000-4			
S204	MIDDLE	8000-2	S309	REAR	8000-4	S551	POWER SEATS	NOT SHOWN
S205	MIDDLE	8000-2	S310	REAR	8000-4			
S206	MIDDLE	8000-2	S313	REAR	8000-4	S552	BOLSTER SUPPORT	NOT SHOWN
S207	MIDDLE	8000-2	S314	REAR	8000-4			
S209	MIDDLE	8000-2	S315	REAR	8000-4	S553	BOLSTER SUPPORT	NOT SHOWN
S210	MIDDLE	8000-2	S316	REAR	NOT SHOWN	S600	SUNROOF	NOT SHOWN
S211	MIDDLE	8000-2						
S212	MIDDLE	8000-2	S319	REAR	8000-4	S601	SUNROOF	NOT SHOWN
S213	MIDDLE	8000-2	S320	REAR	8000-4			
S214	MIDDLE	8000-2	S324	REAR	8000-4			

FRONT HARNESS

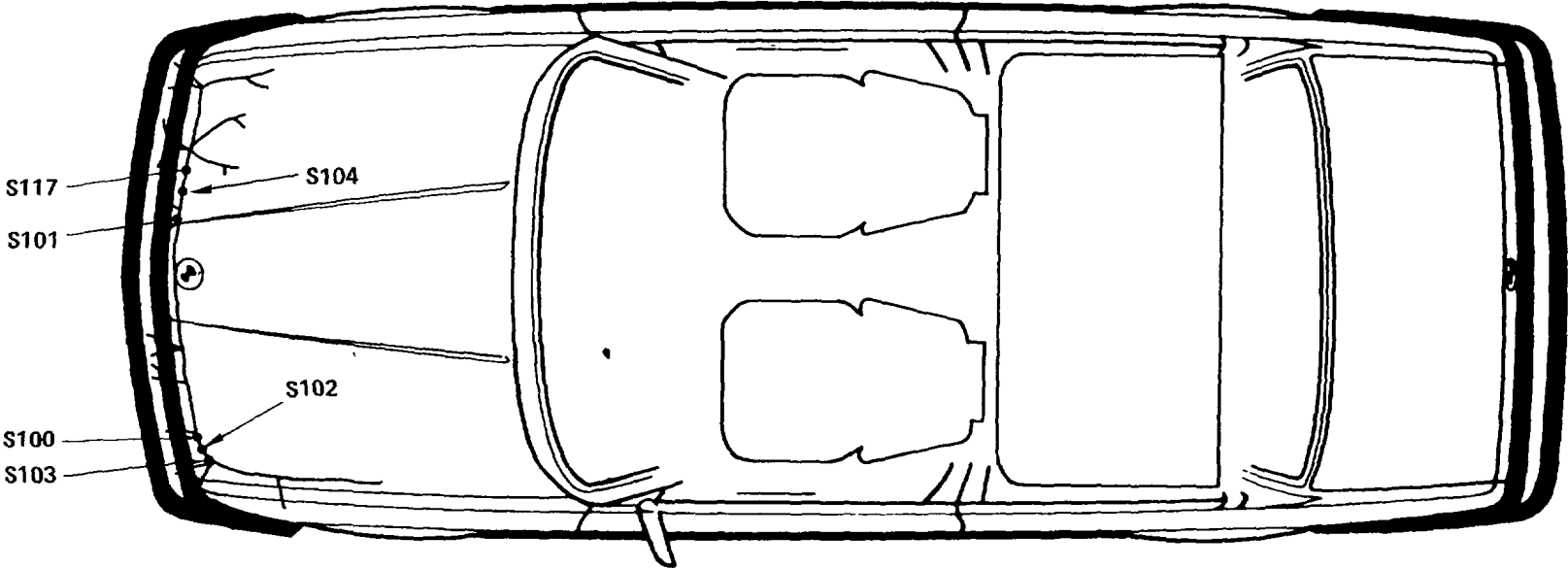

# 8000-2 SPLICE LOCATION VIEWS

## MIDDLE HARNESS

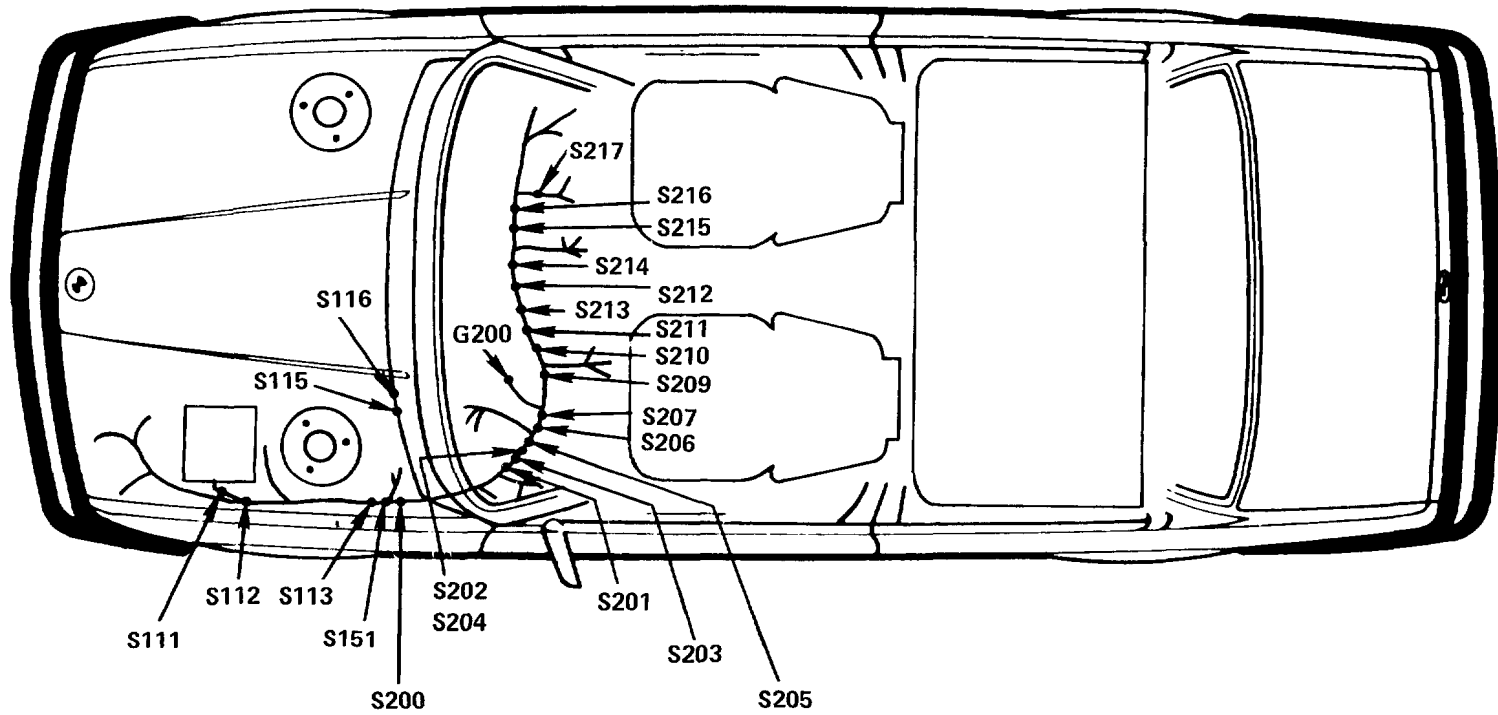

ENGINE HARNESS

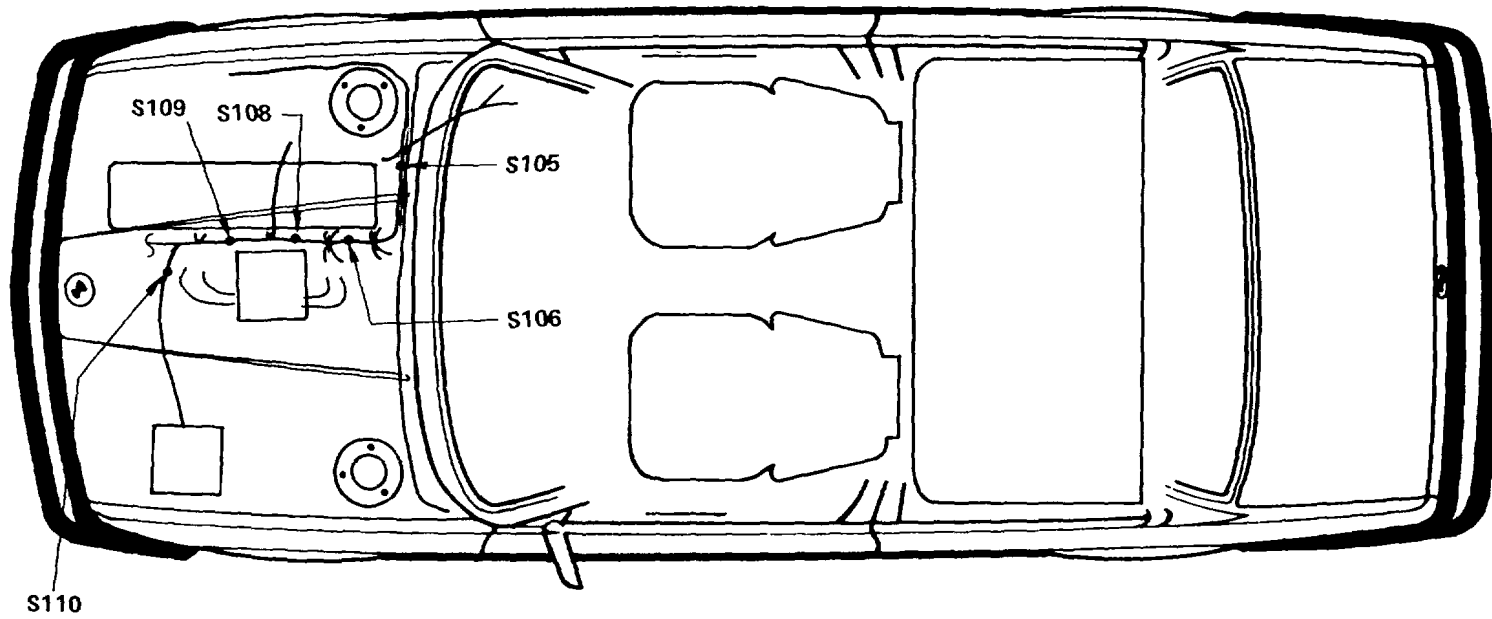

# 8000-4 SPLICE LOCATION VIEWS

## REAR HARNESS

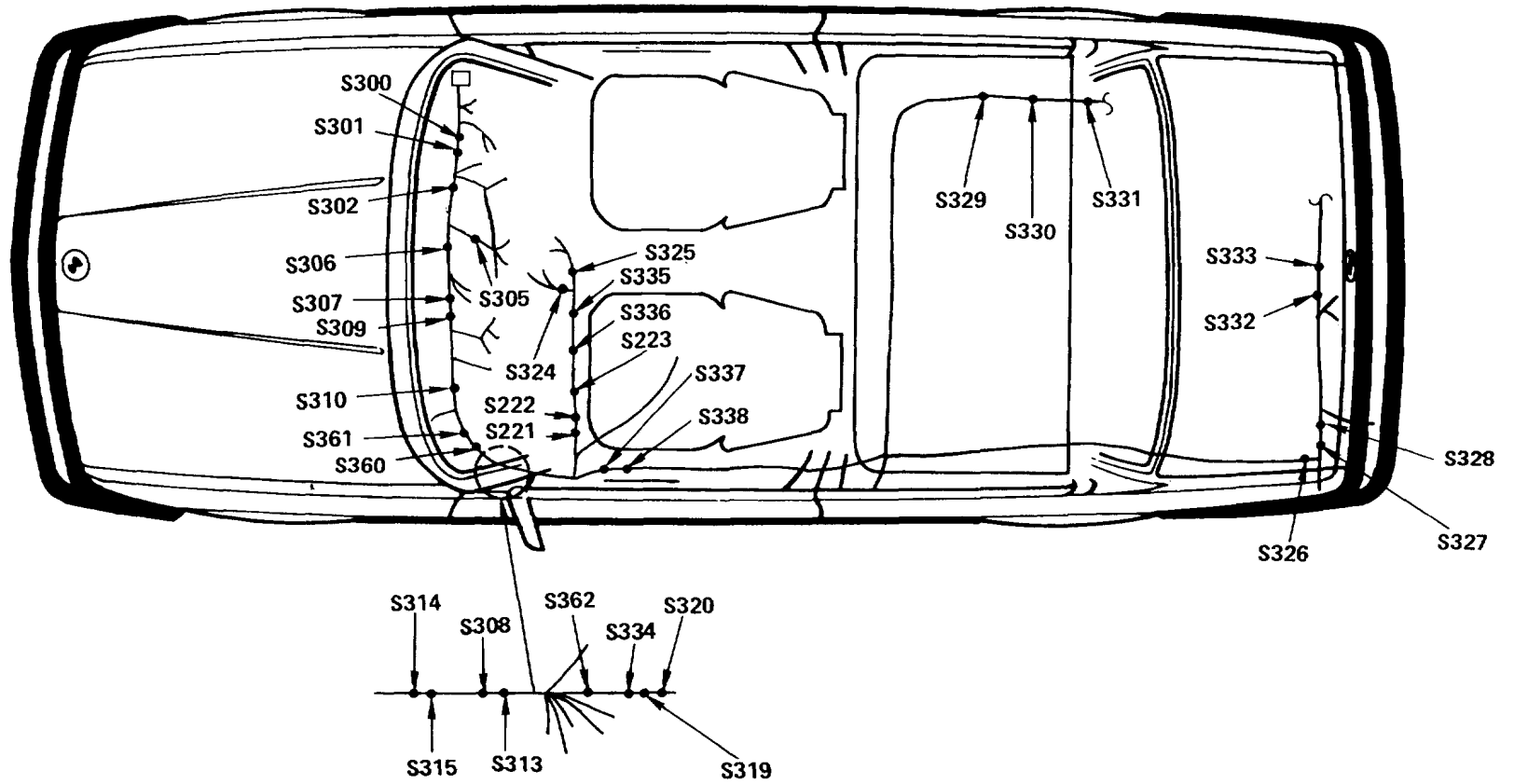

ACCESSORY CONNECTOR (302)

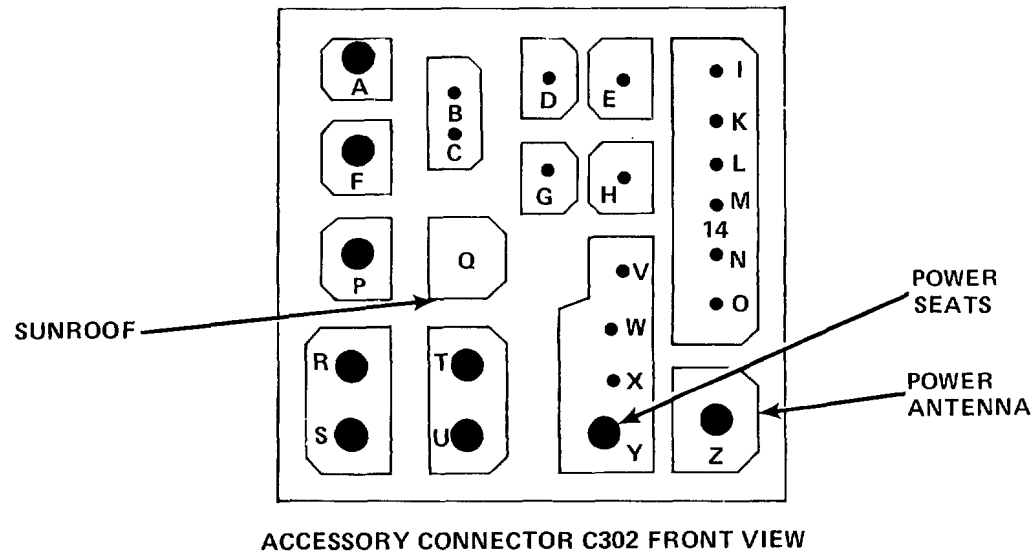
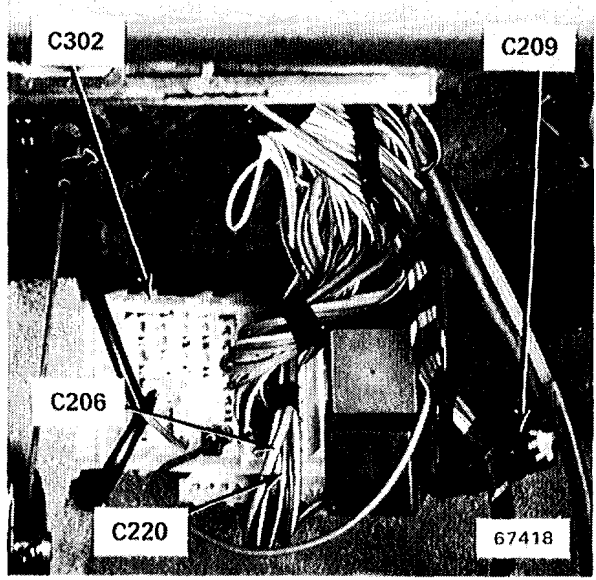

ACCESSORY CONNECTOR C302 FRONT VIEW

Figure 1 - Under Left Side Of Dash

## DIAGNOSTIC CONNECTOR

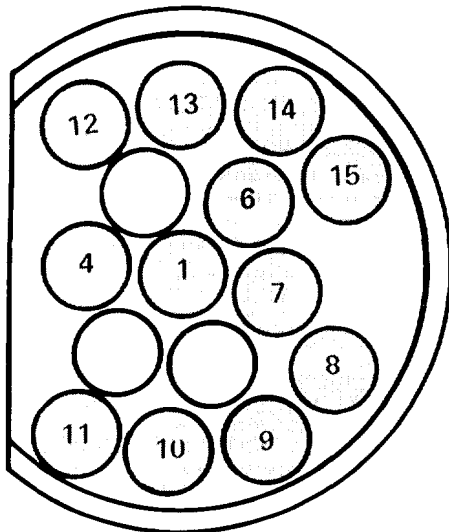

DIAGNOSTIC CONNECTOR FACE

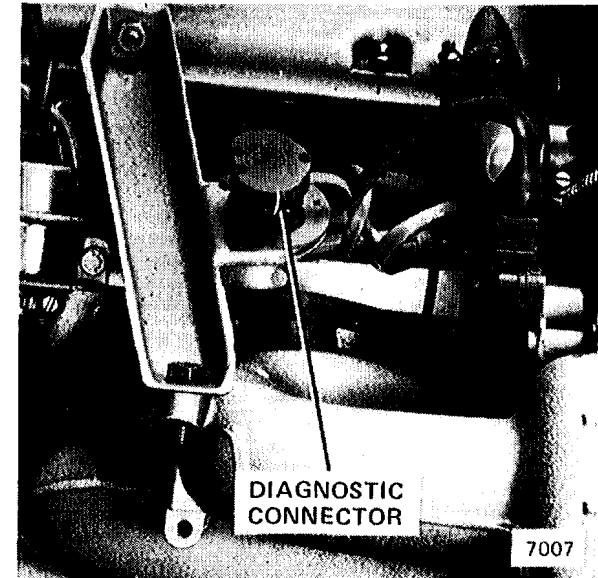
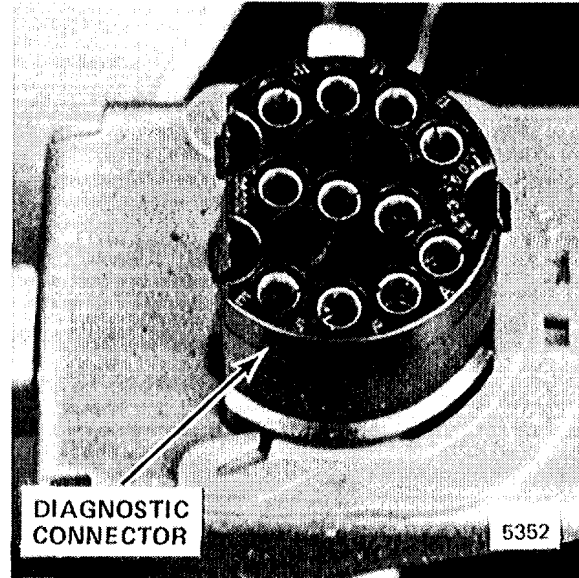
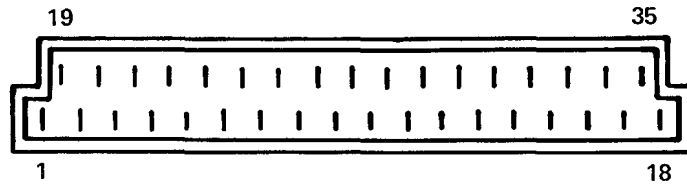

Figure 1 - On Power Distribution Box

PIN	WIRE SIZE	WIRE COLOR	CIRCUIT AND COMPONENT CONNECTED
1	1.5	BR	Ground Distribution, G103
4	.5	BR/WT	Gauges/Warning Indicators, Coolant Temperature Sender.
6	.5	WT/BK	Not Used (Wiring Shown On Charging System)
7	.5	WT/BU	Service Interval Indicator, Service Interval Processor (Reset).
8	.5	YL	Ignition, TDC Sensor.
9		SHIELD	Ignition, TDC Sensor.
10	.5	BK	Ignition, TDC Sensor.
11	2.5	BK/YL	Start, Start Signal.
12	.75	BU	Charge System, Alternator.
13	.75	GN	Ignition, Ignition Coil.
14	2.5	RD	Charge System, Alternator.
15	1.5	GN/YL	Oxygen Sensor, Oxygen Sensor Heater Relay.

# 8500-2 CONNECTOR VIEWS



Wiring Face  
ABS ELECTRONIC CONTROL UNIT

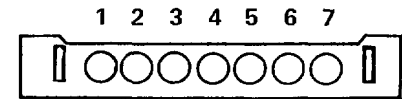

Wiring Face  
AIR DOOR CONTROL

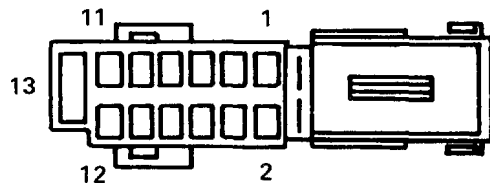

Mating Face  
ABS HYDRAULIC UNIT

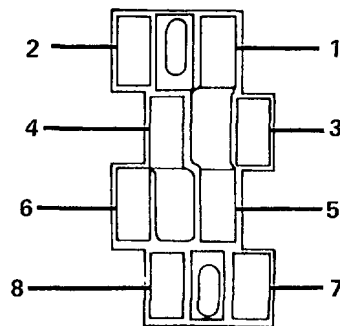

Wiring Face  
A/C SELECTOR SWITCH

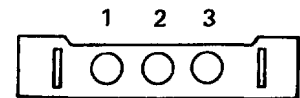

Wiring Face  
AIR DOOR POTENTIOMETER

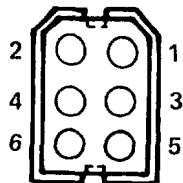

Wiring Face  
A/C BLOWER HOUSING

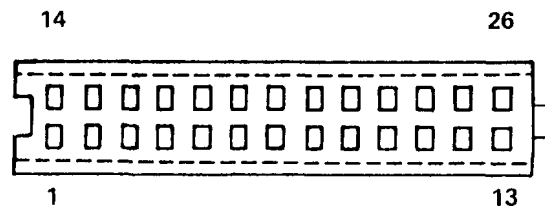

Wiring Face  
ACTIVE CHECK CONTROL UNIT

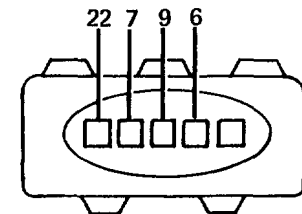

Wiring Face  
AIR FLOW METER



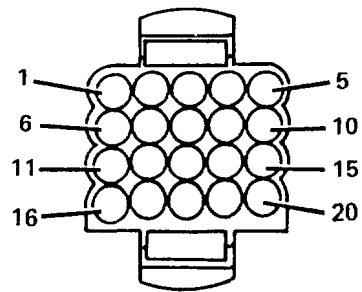

Wiring Face  
AMPLIFIER  
(SOUND SYSTEM)

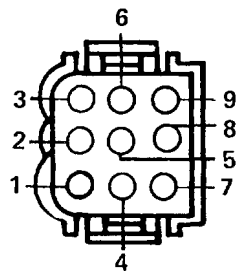

Wiring Face  
AUTOMATIC TRANSMISSION RANGE SWITCH



Wiring Face  
AUXILIARY EVAPORATOR

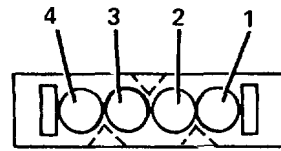

Wiring Face  
AUXILIARY HIGH LEVEL STOP LIGHT

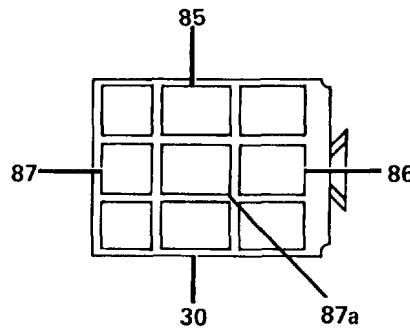

Wiring Face  
BLOWER SELECT RELAY

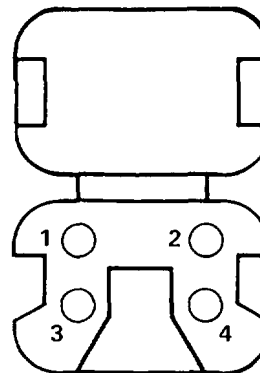

Wiring Face  
BLOWER SPEED CONTROL (C1)

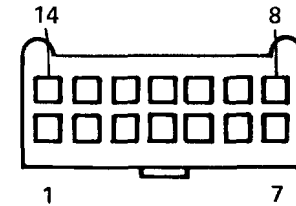

Wiring Face  
CENTRAL LOCKING CONTROL UNIT

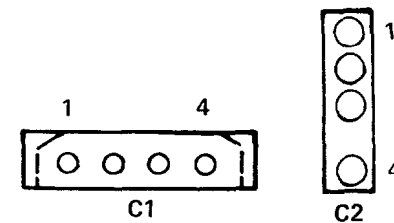

Wiring Face  
CHIME MODULE

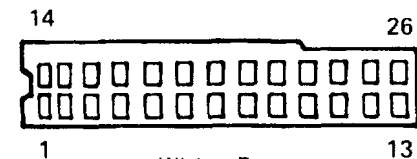

Wiring Face  
CRUISE CONTROL CONTROL UNIT

# 8500-4 CONNECTOR VIEWS

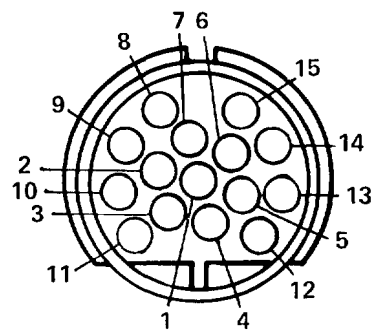

Mating Face  
DIAGNOSTIC CONNECTOR

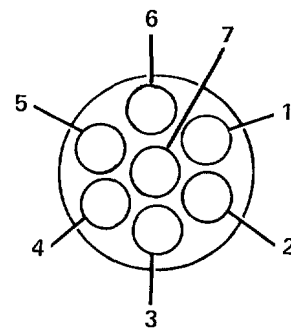

Wiring Face  
DRIVER'S SEAT (C8)

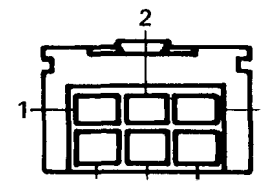

Wiring Face  
EVAPORATOR TEMPERATURE REGULATOR

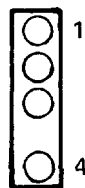

Wiring Face  
DIGITAL CLOCK

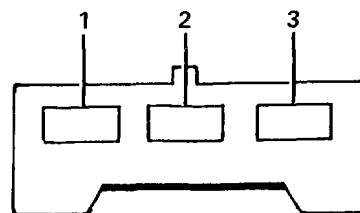

Wiring Face  
DRIVER'S SEAT (C9,C10,C11,C12)

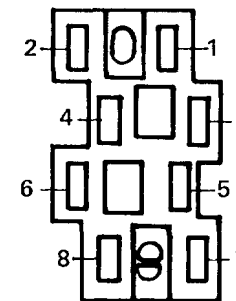

Mating Face  
FADER CONTROL

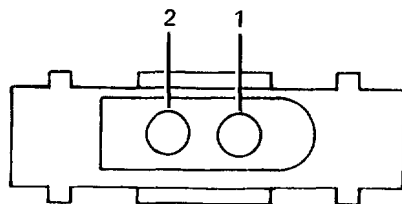

Wiring Face  
DRIVER'S SEAT (C6,C7,C13,C14)

YL BK SHIELD

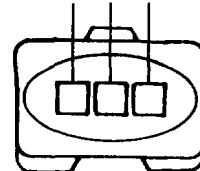

(BLACK)

Engine Harness Wiring Face  
ENGINE SPEED SENSOR

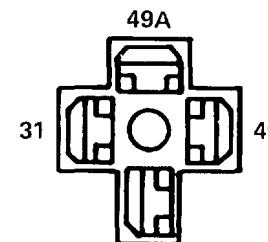

Wiring Face  
FLASHER

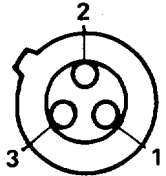

Wiring Face  
FRONT TURN PARK LIGHT

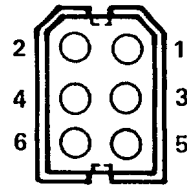

Wiring Face  
HEATER BLOWER HOUSING

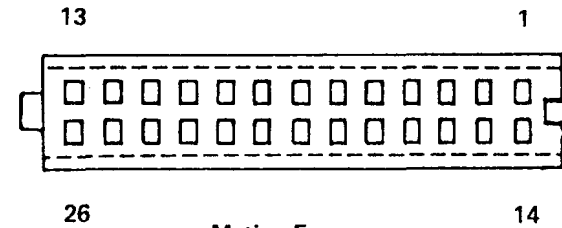

Mating Face  
INSTRUMENT CLUSTER  
C1= (BLUE)  
C2= (WHITE)  
C3= (YELLOW)

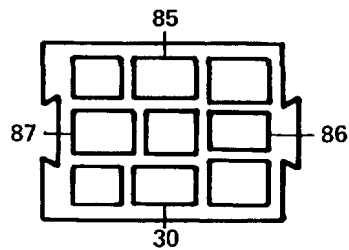

Wiring Face  
FUEL PUMP RELAY

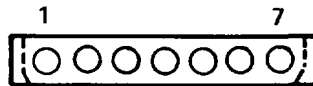

Wiring Face  
HEATER REGULATOR

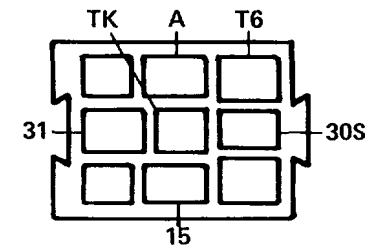

Wiring Face  
INTERIOR LIGHT TIMER CONTROL

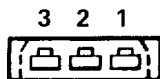

Wiring Face  
FUEL TANK SENDER

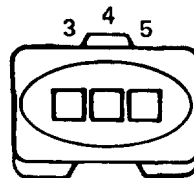

Wiring Face  
IDLE SPEED ACTUATOR

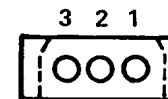

Wiring Face  
INTERIOR TEMPERATURE SENSOR

# 8500-6 CONNECTOR VIEWS

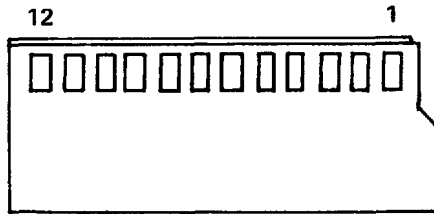

Mating Face  
LIGHT SWITCH

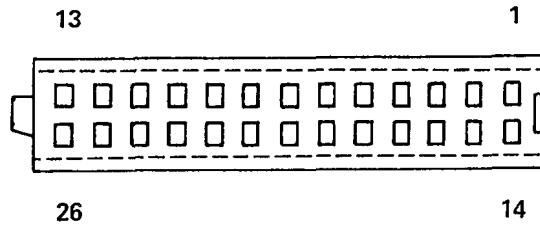

Wiring Face  
MEMORY SEAT CONTROL UNIT (C1)

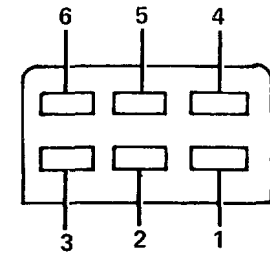

Wiring Face  
MEMORY SEAT CONTROL UNIT (C4)

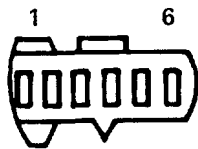

Wiring Face  
LOCK MOTOR (CENTRAL LOCKING)

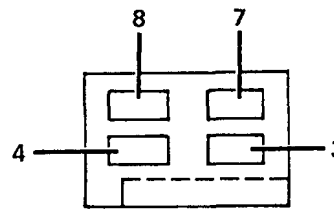

Wiring Face  
MEMORY SEAT CONTROL UNIT (C2)

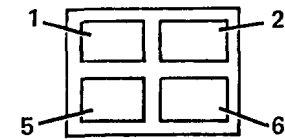

Wiring Face  
MEMORY SEAT CONTROL UNIT (C5)

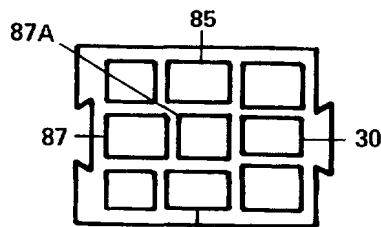

Wiring Face  
MAIN RELAY

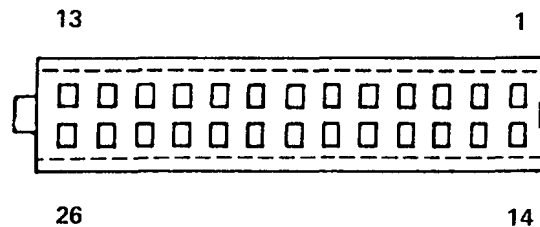

Wiring Face  
MEMORY SEAT CONTROL UNIT (C3)

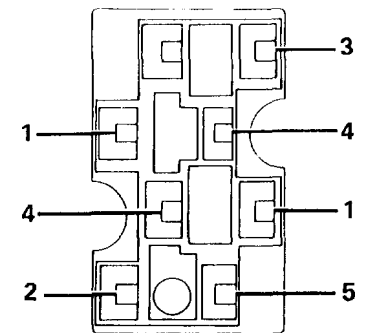

Wiring Face  
MEMORY SWITCH

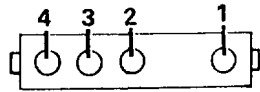

Wiring Face  
MIRROR

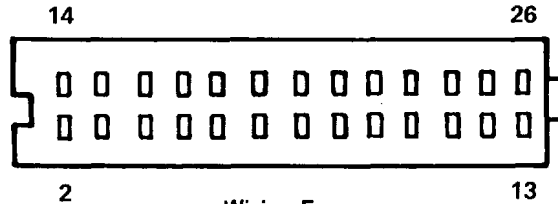

Wiring Face  
ON BOARD COMPUTER MODULE

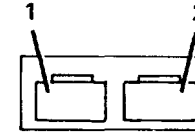

Wiring Face  
PROGRAM SWITCH (C1)  
(ELECTRONIC TRANSMISSION)

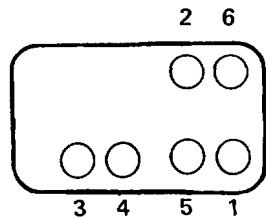

Mating Face  
MIRROR CONTROL SWITCH



Wiring Face C1      Wiring Face C2  
ON-BOARD COMPUTER RELAY BOX

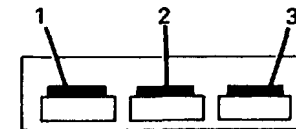

Wiring Face  
PROGRAM SWITCH (C2)  
(ELECTRONIC TRANSMISSION)

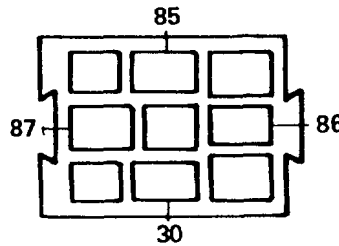

Wiring Face  
OXYGEN SENSOR HEATER RELAY

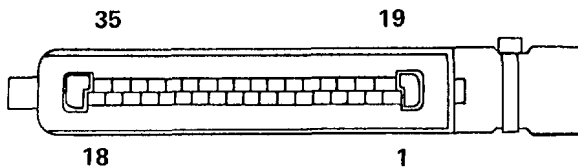

Mating Face  
MOTRONIC CONTROL UNIT

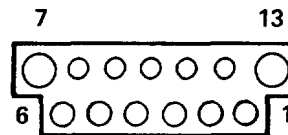

Wiring Face  
PASSENGER SEAT CONTROLLER (C1)

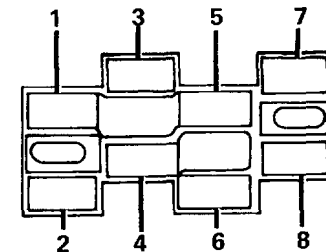

Wiring Face  
REAR DEFOGGER SWITCH

# 8500-8 CONNECTOR VIEWS

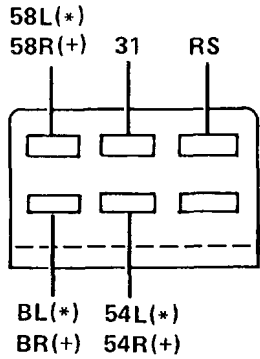

BL(\*) 54L(\*)  
BR(+) 54R(+)

(\*)=LEFT SIDE  
(+)=RIGHT SIDE

REAR LIGHT ASSEMBLY

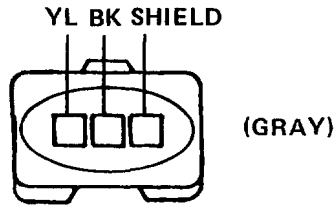

YL BK SHIELD

(GRAY)

Engine Harness Wiring Face  
REFERENCE POINT SENSOR

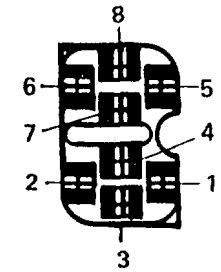

Wiring Face  
SEATSWITCH (C2)  
(FRONT/REAR)

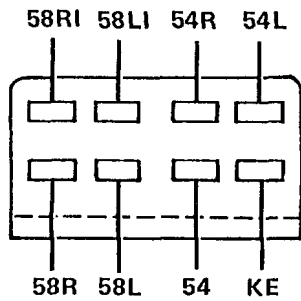

Wiring Face  
REAR LIGHTS CHECK RELAY (C1)

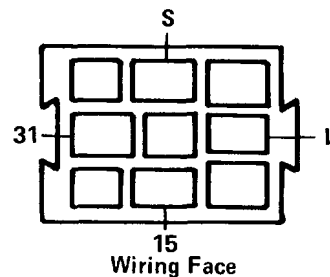

Wiring Face  
SEAT BELT WARNING TIMER

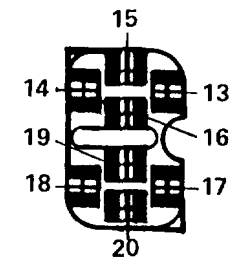

Wiring Face  
SEAT SWITCH (C3)  
(ENTIRE SEAT/SEAT BACK RECLINER)

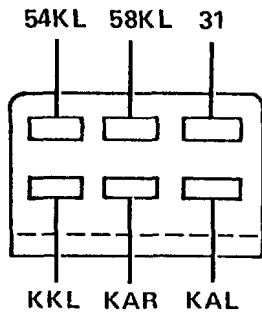

Wiring Face  
REAR LIGHTS CHECK RELAY (C2)

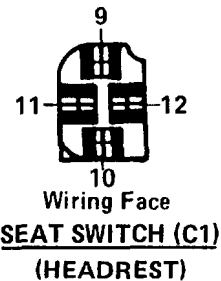

Wiring Face  
SEAT SWITCH (C1)  
(HEADREST)

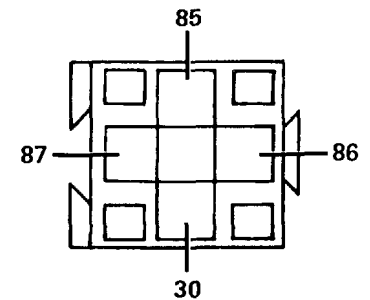

Wiring Face  
START RELAY

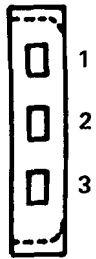

Wiring Face  
SUNROOF MOTOR (CI)

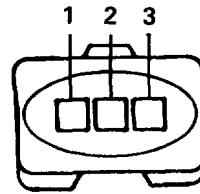

Wiring Face  
THROTTLE SWITCH  
(MANUAL TRANSMISSION)

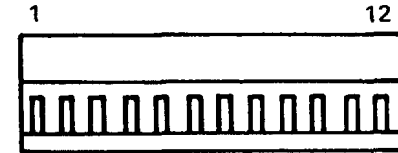

Wiring Face  
TRANSMISSION RANGE DISPLAY

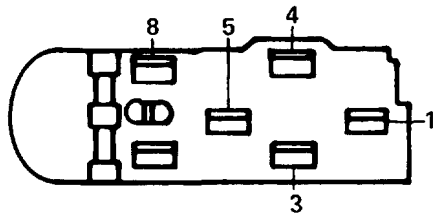

Wiring Face  
SUNROOF SWITCH

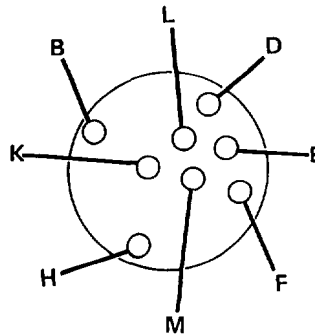

Wiring Face  
TRANSMISSION

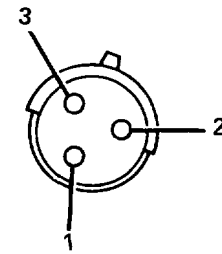

Mating Face  
UNLOCK INHIBIT SWITCH

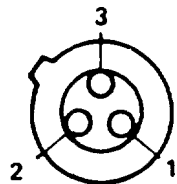

Wiring Face  
THROTTLE POSITION SENSOR  
(ELECTRONIC TRANSMISSION)

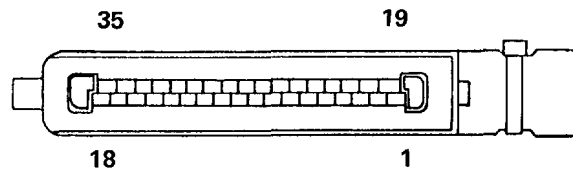

Mating Face  
TRANSMISSION CONTROL UNIT

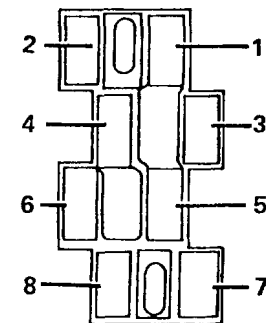

Wiring Face  
WINDOW SWITCHES

8500-10 CONNECTOR VIEWS

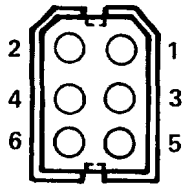

Wiring Face  
WIPER MOTOR

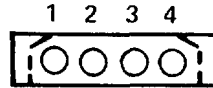

Wiring Face  
C103

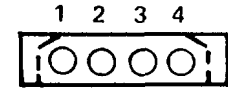

Wiring Face  
C132

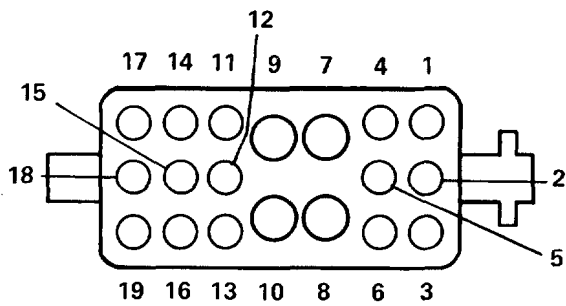

Wiring Face  
C101

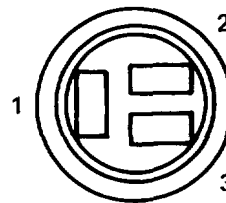

Wiring Face  
C113

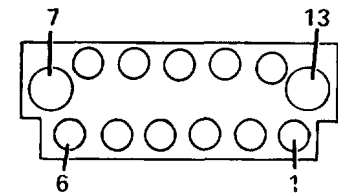

Wiring Face  
C133

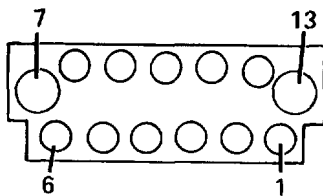

Wiring Face  
C102



Wiring Face  
C114

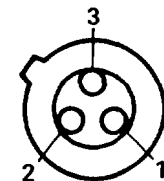

Wiring Face  
C141



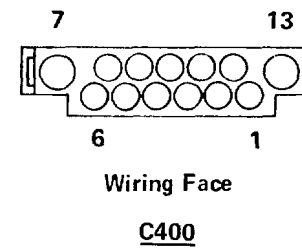
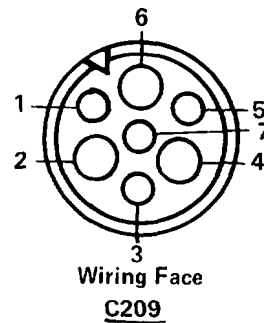
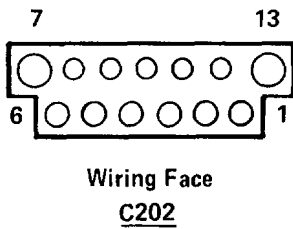
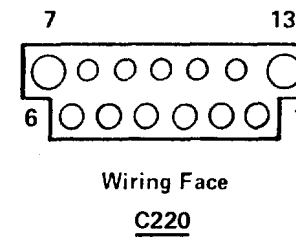
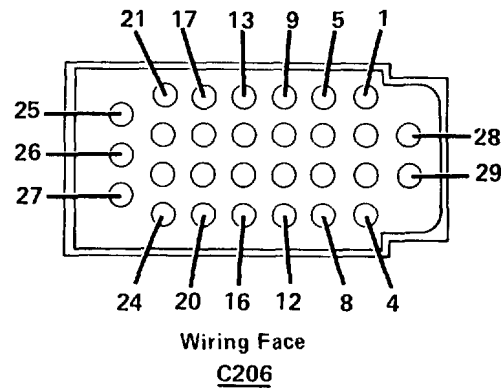
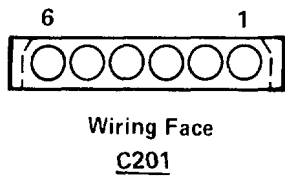
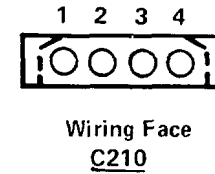
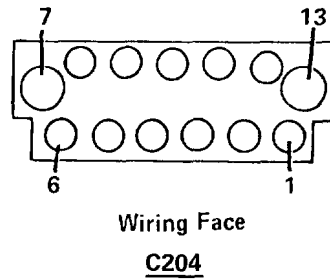
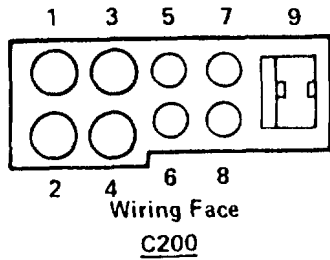

# 8500-12 CONNECTOR VIEWS

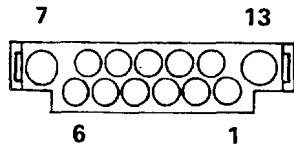

Wiring Face  
C401

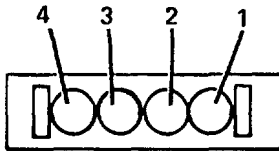

Wiring Face  
C402

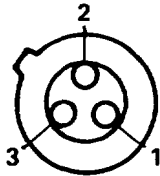

Wiring Face  
C503

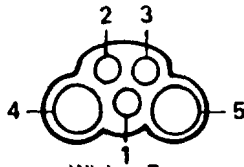

Wiring Face  
C551

## 9000-0 COMPONENT LOCATION CHART

COMPONENTS	Page-Figure
A/C Blower Housing . . . . .	Behind center console
A/C Final Stage . . . . .	Inside A/C blower housing
A/C In-Line Diode . . . . .	On RH side of A/C compressor . . . . . 7000-2-5
ABS Electronic Control Unit . . .	Below right side of windshield, behind shock tower . 7000-0-3
ABS Hydraulic Unit . . . . .	Right of left front wheel well . . . . . 7000-0-1
Active Check Control Module . .	In dash, left of steering column
Air Door Control . . . . .	Under dash, left of glove box
Air Flow Meter . . . . .	Top right side of engine . . . . . 7000-1-6
Amplifier . . . . .	RH side of trunk . . . . . 7000-6-1
Auto-Charging Flashlight . . . .	In glove box
Auto. Trans. Range Switch . . .	On left side of shift lever
Auxiliary Fan . . . . .	Ahead of radiator . . . . . 7000-3-1
Auxiliary Fan Blocking Diode . .	Inside front harness, near RH headlights
Auxiliary Fuel Pump . . . . .	RH side of trunk floor, below access panel . . . . . 7000-6-2
B/C Horn Diode . . . . .	Near alarm horn
Back Up Light Switch . . . . .	On left side of manual transmission
Blower Select Relay . . . . .	Under dash, left of glove box . . . . . 7000-4-6
Board Computer Horn . . . . .	Under left side of fresh air intake cowl . . . . . 7000-0-6
Brake Accum. Pres. Switch . . .	Right of left front shock tower . . . . . 7000-1-4
Brake Fluid Level Switch . . . .	To left of engine, on brake fluid reservoir . . . . . 7000-1-4
Brake Switch . . . . .	Above brake pedal . . . . . 7000-3-4
Central Locking Control Unit . .	Under dash, left of glove box . . . . . 7000-4-6
Chime Module . . . . .	Under LH side of dash, on hush panel . . . . . 7000-3-5
Clutch Switch . . . . .	Above clutch pedal . . . . . 7000-3-4
Cold Start Valve . . . . .	Between intake ports 3 and 4
Combination Switch . . . . .	On LH side of steering column . . . . . 7000-4-4
Compressor Clutch . . . . .	On front of A/C compressor
Coolant Level Switch . . . . .	Top of coolant reservoir . . . . . 7000-1-3
Coolant Temperature Sender/ Switch . . . . .	Front of engine, on thermostat housing . . . . . 7000-0-4
Coolant Temperature Sensor . .	Front of engine, top of thermostat housing . . . . . 7000-0-4
Cruise Control Actuator . . . . .	RH side of LH front wheel well . . . . . 7000-0-1
Cruise Control Control Unit . . .	Under LH side of dash, above speaker . . . . . 7000-4-3
Diagnostic Connector . . . . .	On LH front wheel well, near power distribution box . 7000-0-1
Door Lock Motors . . . . .	In each door, behind panel . . . . . 7000-5-6
Driver's Seat Controller . . . . .	Under driver's seat, on frame
Driver's Seat Switches . . . . .	On center console, left of shift lever . . . . . 7000-5-5
Engine Speed Sensor . . . . .	On LH side of transmission bell housing . . . . . 7000-1-6
Evaporator Temp. Regulator . . .	On left side of heater-A/C unit . . . . . 7000-3-3
Evaporator Temperature Sensor	In center console, below back of radio

## COMPONENT LOCATION CHART 9000-1

Fader Control . . . . .	In center console, below radio face . . . . .	7000-5-3
Filter Capacitor . . . . .	On back of alternator	
Flasher . . . . .	Upper left side of steering column . . . . .	7000-4-4
Front Speed Detectors . . . . .	Back of front wheels, on dust shields . . . . .	7000-7-4
Fuel Injectors . . . . .	Top of engine, near each cylinder	
Fuel Pump Relay . . . . .	On power distribution box . . . . .	7000-1-1
Fuel Tank Sender Switch . . . . .	RH side of trunk floor, below access panel . . . . .	7000-6-2
Gas Filler Lock Motor . . . . .	In trunk, behind right rear wheel well . . . . .	7000-6-1
Heater Blower Housing . . . . .	Behind center console	
Heater Final Stage . . . . .	Inside heater blower housing	
Heater Regulator . . . . .	Behind temperature select control . . . . .	7000-3-3
High Pressure Cut-Out Switch . . . . .	On receiver-drier . . . . .	7000-0-2
High Speed Coolant Temp. Switch . . . . .	Upper right side of radiator (red terminals). . . . .	7000-2-1
Horn Brush/Slip Ring . . . . .	Under hub of steering wheel	
Horn Switches . . . . .	On steering wheel	
Hydraulic Pressure Switch . . . . .	Right of left front shock tower. . . . .	7000-1-5
Idle Speed Actuator . . . . .	Top right side of engine . . . . .	7000-0-5
Ignition Coil . . . . .	On right wheel well, behind headlights . . . . .	7000-0-2
Ignition Key Switch . . . . .	In upper part of steering column . . . . .	7000-4-4
Ignition Switch . . . . .	In upper part of steering column . . . . .	7000-4-4
Intensive Washer Pump . . . . .	Behind right front shock tower, in reservoir . . . . .	7000-0-3
Interior Light Timer Control . . . . .	Under LH side of dash, on body electrical bracket. . . . .	7000-4-1
Interior Temperature Sensor . . . . .	Under LH side of dash . . . . .	7000-3-5
Jet Heaters . . . . .	On washer jet nozzles	
LH Front Brake Wear Sensor . . . . .	Near caliper, connected to brake pad . . . . .	7000-7-1
Lock Heater . . . . .	In left front door, on door lock	
Lock Heater Control Unit . . . . .	In left front door, near door lock	
Lock Inhibit Switch . . . . .	In passenger's door, at lock cylinder	
Main Fuel Pump . . . . .	Under car, above right rear axle	
Main Relay . . . . .	On power distribution box . . . . .	7000-0-1
Memory Seat Control Module . . . . .	Under front of driver's seat	
Memory Switches . . . . .	On center console, left of shift lever . . . . .	7000-5-5
Motronic Control Unit . . . . .	Under RH side of dash, above glove box . . . . .	7000-4-5
Normal Speed Blower Resistor . . . . .	Ahead of radiator, on auxiliary fan shield. . . . .	7000-3-1
Normal Speed Cool. Temp. Switch . . . . .	Upper right side of radiator (white terminals). . . . .	7000-2-1
Normal Washer Pump . . . . .	Ahead of RH front wheel well, in reservoir. . . . .	7000-2-2
Oil Level Sensor . . . . .	Bottom of engine oil pan. . . . .	7000-7-2

## 9000-2 COMPONENT LOCATION CHART

---

Oil Pressure Switch . . . . .	Left rear end of cylinder head . . . . .	7000-2-4
On-Board Computer Module . . .	In center console, right of radio face. . . . .	7000-5-3
On-Board Computer Relay Box .	Under LH side of dash, above speaker . . . . .	7000-4-3
Outside Temperature Sensor . .	Under left front side of bumper	
Oxygen Sensor . . . . .	Underneath car, on catalytic converter	
Oxygen Sensor Heater Relay . .	On power distribution box . . . . .	7000-1-1
Park Brake Switch . . . . .	In shift console, at base of parking brake	
Passenger's Seat Controller . . .	Under passenger's seat, on frame	
Passenger's Seat Switches . . .	On center console, right of shift lever. . . . .	7000-5-5
Potentiometer . . . . .	Under dash, left of glove box	
Power Antenna . . . . .	RH side of trunk, near hinge . . . . .	7000-6-5
Power Distribution Box . . . . .	Top front of left front wheel well . . . . .	7000-1-1
Power Window Circuit Breaker .	In center console, below radio face . . . . .	7000-5-3
Program Selector Switch . . . . .	On center console, to right of shift lever . . . . .	7000-5-4
Pulse Wheels . . . . .	Inner sides of rotors. . . . .	7000-7-3
Rear Lights Check Relay . . . . .	In trunk, left of rear panel center support . . . . .	7000-6-3
Rear Speed Detectors . . . . .	Back of rear wheels, near brake assembly . . . . .	7000-7-3
Reference Point Sensor . . . . .	On LH side of transmission bell housing . . . . .	7000-1-6
RH Rear Brake Wear Sensor . . .	Near caliper, connected to brake pad . . . . .	7000-7-1
Safety Switch . . . . .	In center console, to left of shift lever. . . . .	7000-5-4
Seatbelt Switch . . . . .	In driver's seatbelt buckle	
Seatbelt Warning Timer . . . . .	Under LH side of dash, on body electrical bracket. . .	7000-4-1
Speedometer Sender . . . . .	In rear of differential	
Start Relay . . . . .	Under LH side of dash, on body electrical bracket. . .	7000-4-1
Starter . . . . .	Lower LH rear of engine	
Stepping Motor . . . . .	Under dash, left of glove box	
Sunroof Motor . . . . .	Above headliner, above rear view mirror	
Sunroof Motor Relay . . . . .	Above headliner, above rear view mirror	
TDC Sensor . . . . .	Above crankshaft vibration damper . . . . .	7000-2-5
Thermo-Time Switch. . . . .	Front of engine, top of thermostat housing . . . . .	7000-0-4
Throttle Position Sensor . . . . .	Top center of engine, behind rubber boot . . . . .	7000-2-3
Throttle Switch . . . . .	Top LH side of engine, below throttle body . . . . .	7000-2-3
Transmission Control Unit . . . .	Under LH side of dash, above speaker . . . . .	7000-4-3
Transmission Kickdown Switch	Passenger compartment, under accelerator pedal	
Trunk Light Switch . . . . .	In trunk lid, near trunk lock	
Trunk Lock Motor . . . . .	In trunk, in trunk lock support . . . . .	7000-6-3
Underhood Light Switch . . . . .	Left of right hood hinge	
Unlock Inhibit Switch . . . . .	In driver's door, at lock cylinder	
Washer Fluid Level Switch . . . .	Ahead of right front wheel well, in reservoir . . . . .	7000-0-2

Water Shut-Off Valve . . . . .	Center rear of engine compartment . . . . .	7000-1-5
Window Motors . . . . .	In each door, behind panel	
Wiper Motor . . . . .	Under left side of fresh air intake cowl . . . . .	7000-0-6

**CONNECTORS**

C101 (17 pin) . . . . .	On right side of power distribution box . . . . .	7000-0-1
C102 (13 pin) . . . . .	Inside power distribution box . . . . .	7000-2-6
C103 (4 pin) . . . . .	Under RH side of dash, above glove box . . . . .	7000-4-5
C106 (1 pin) . . . . .	Behind right headlights . . . . .	7000-2-2
C110 (2 pin) . . . . .	Ahead of right headlights' access panel	
C111 (2 pin) . . . . .	Underside of hood, near LH washer jet nozzle	
C112 (2 pin) . . . . .	Underside of hood, near RH washer jet nozzle	
C113 (3 pin) . . . . .	Left side of auxiliary fan shield . . . . .	7000-3-1
C114 (8 pin) . . . . .	In power distribution box, on underside of printed circuit board	
C115 (2 pin) . . . . .	In power distribution box, on underside of printed circuit board	
C126 (2 pin) . . . . .	Behind left side of front spoiler	
C127 (2 pin) . . . . .	Behind right side of front spoiler	
C132 (4 pin) . . . . .	Under RH side of dash, above glove box . . . . .	7000-4-5
C133 (13 pin) . . . . .	Under right side of dash, above glove box	
C141 (3 pin) . . . . .	Mounted underneath car, left of transmission	
C150 (2 pin) . . . . .	Behind LH front shock tower . . . . .	7000-0-6
C151 (2 pin) . . . . .	Behind RH front shock tower . . . . .	7000-0-3
C152 (8 pin) . . . . .	Under center of car, near transmission	
C200 (10 pin) . . . . .	Under LH side of dash, on LH side of steering column . . . . .	7000-3-2
C201 (6 pin) . . . . .	Under LH side of dash, on LH side of steering column . . . . .	7000-3-2
C202 (13 pin) . . . . .	Under LH side of dash, on LH side of steering column . . . . .	7000-3-2
C204 (13 pin) . . . . .	Behind center console, above radio	
C205 (1 pin) . . . . .	Under LH side of dash	
C206 (29 pin) . . . . .	Under LH side of dash, on body electrical bracket . . .	7000-4-2
C208 (2 pin) . . . . .	Above clutch pedal . . . . .	7000-3-4
C209 (7 pin) . . . . .	Under LH side of dash, near body electrical bracket .	7000-4-2
C210 (4 pin) . . . . .	Under LH side of dash, on LH side of steering column . . . . .	7000-3-2
C214 (2 pin) . . . . .	Under LH side of dash, near steering column	
C215 (2 pin) . . . . .	Behind radio	

## 9000-4 COMPONENT LOCATION CHART

---

C216 (2 pin)	Behind radio	
C219 (2 pin)	RH side of trunk, near antenna	7000-6-5
C220 (13 pin)	Under LH side of dash, on body electrical bracket	7000-4-2
C250 (6 pin)	Under LH side of dash	
C300 (2 pin)	Base of left trunk hinge	7000-6-4
C301 (2 pin)	In center console, ahead of shift lever	
C302 (Accessory Connector)	Under LH side of dash, on body electrical bracket	7000-4-2
C305 (4 pin)	Under LH side of dash	
C351 (2 pin)	RH front of trunk	
C352 (2 pin)	LH front of trunk	7000-6-6
C400 (13 pin)	Behind LH front speaker	7000-3-6
C401 (13 pin)	Behind RH front speaker	7000-5-1
C402 (4 pin)	Behind LH front speaker	7000-3-6
C503 (3 pin)	In lower rear corner of driver's door	7000-5-6
C520 (2 pin)	In lower rear corner of driver's door	7000-5-6
C551 (2 pin)	Under center console	
C552 (5 pin)	Under driver's seat	
C553 (5 pin)	Under driver's seat	
C560 (2 pin)	In driver's door	

### GROUNDS

G101	LH side of engine, on motor mount	
G103 (Engine Ground)	Top rear of engine	7000-1-6
G104 (Main Body Ground)	Inner side of LH fender, near battery	7000-1-2
G106	On right hood hinge	
G200 (Front Interior Ground)	On dash frame, left of steering column	
G201 (Column Ground)	On upper left side of steering column	7000-4-4
G302 (Rear Interior Ground)	Under LH side of rear seat	7000-5-2
G303	Above left B pillar	
G600	Above headliner, above rear view mirror	

---